



ELAN
WORKSHOP
MANUAL

LOTUS CARS (SERVICE) LTD., • NORWICH • NORFOLK • (NOR 92W)



**ELAN
WORKSHOP
MANUAL**

LOTUS CARS (SERVICE) LIMITED
NORWICH . NORFOLK . NOR 92W

Cables: Lotus, Norwich.
Part No. 26T327

Telephone: Wymondham 3411
Telex: 97401

CONTENTS

	<i>Section</i>
TECHNICAL SPECIFICATION	A
INTRODUCTION TO THE VEHICLE	B
SERVICE INFORMATION	C
LUBRICATION	D
ENGINE	E
CLUTCH	F
GEARBOX	G
PROPELLER SHAFT	H
REAR SUSPENSION DIFFERENTIAL AND FINAL DRIVE ...	I
FRONT SUSPENSION AND STEERING GEAR	J
BRAKES	K
ELECTRICAL EQUIPMENT	L
FUEL SYSTEM	M
COOLING SYSTEM	N
CHASSIS UNIT	O
BODY UNIT	P
BODY EQUIPMENT	Q
OVERHAUL AND REBUILD INSTRUCTIONS	R

FILE NOT TO BE REDISTRIBUTED FOR PROFIT ORIGINAL COPYRIGHT HOLDER LOTUS CARS LIMITED 1966

SECTION A

TECHNICAL SPECIFICATION

	<i>Chapter</i>
Lotus Elan — Cutaway	<i>Illustration</i>
Lotus Elan — General Arrangement	<i>Illustration</i>
General	1
Frame	2
Body	3
Front Suspension	4
Rear Suspension	5
Engine	6
Clutch	7
Gearbox	8
Final Drive	9
Brakes	10
Wheels	11
Steering	12
Electrical System	13
Fuel System	14
Body Equipment	15
Dimensions	16

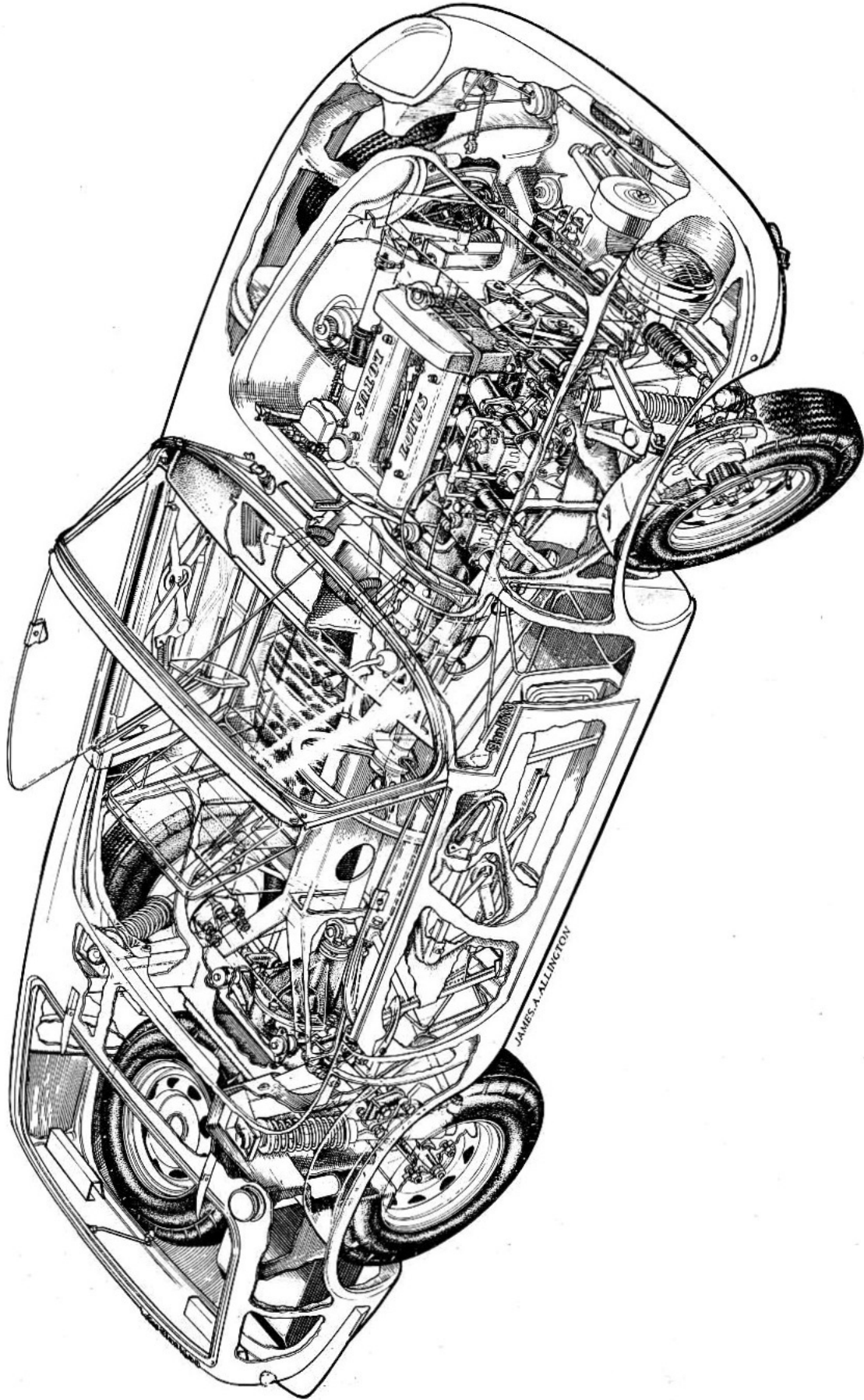

LOTUS ELAN—CUTAWAY

FILE NOT TO BE REDISTRIBUTED FOR PROFIT ORIGINAL COPYRIGHT HOLDER LOTUS CARS LIMITED 1966

FILE NOT TO BE REDISTRIBUTED FOR PROFIT ORIGINAL COPYRIGHT HOLDER LOTUS CARS LIMITED 1966

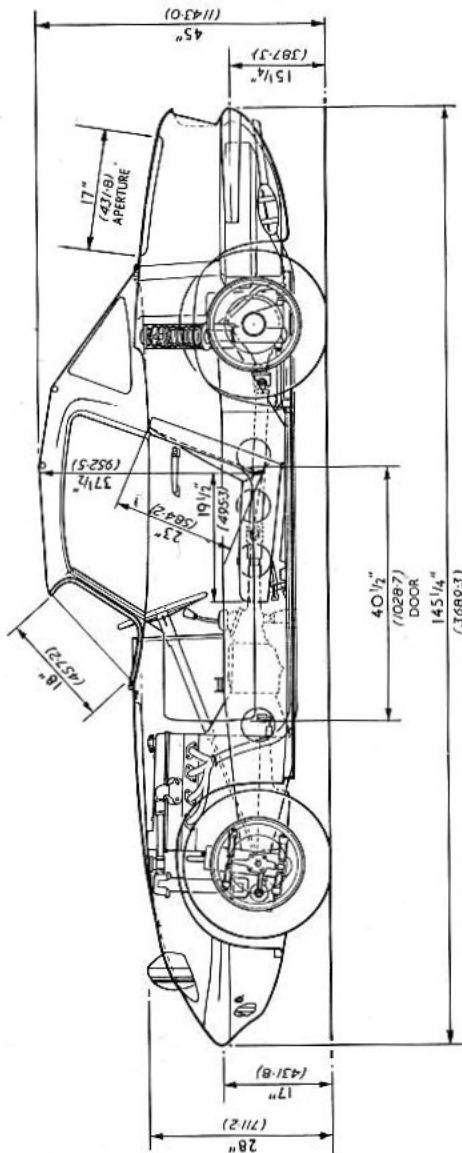
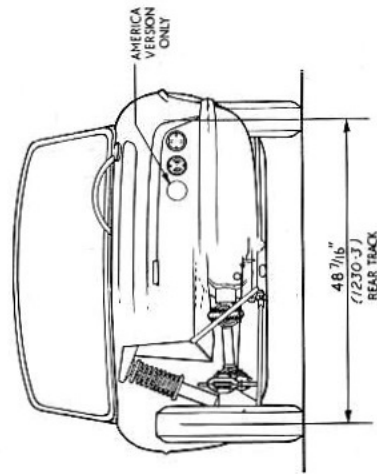
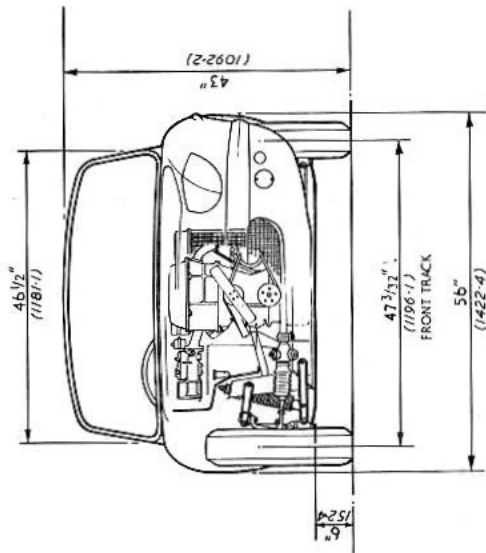

DIMENSION FROM FRONT OF SEAT TO PEDALS • 23 1/2" (596.9) MAX.
• 16 1/2" (419.1) MIN.

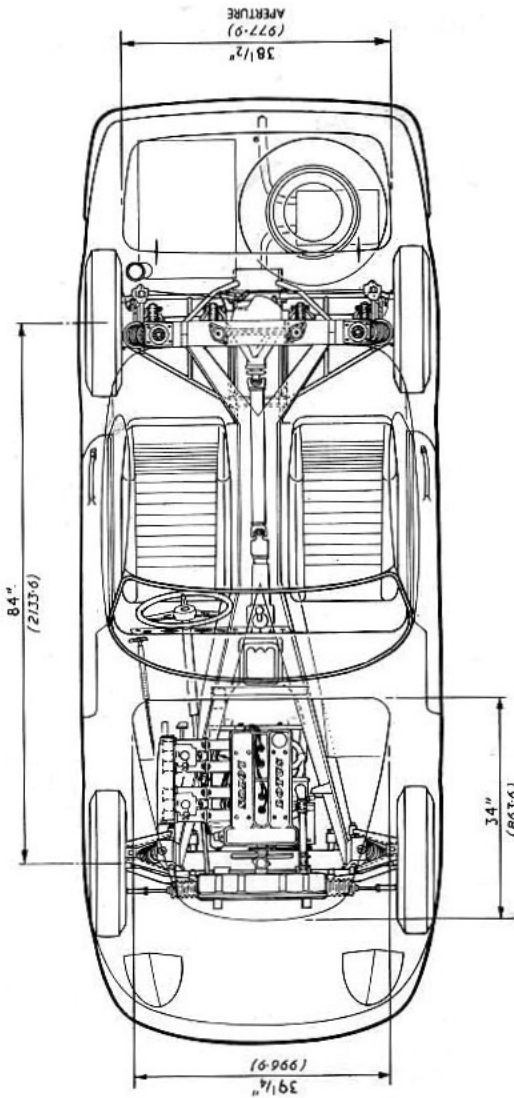

1—General.

Cars carry the prefix 26 commencing 0001 on vehicle number plate. Date of commencement of manufacture January 1963.

It is essential to quote this identification number and engine number if applicable in all enquiries or correspondence concerning the vehicle. Number plate secured to passenger side of bulkhead. Certain components are the subject of pending applications and granted patents in the United Kingdom and Overseas.

2—Frame.

Welded steel backbone chassis, fully rustproofed, providing exceptional torsional rigidity. Strong fabricated suspension mounting points with all loads taken by chassis frame. Rear suspension struts attached to frame by 'Lotocone' flexible mountings at top extremities. Power units and final drive unit flexibly mounted within chassis frame structure.

3—Body.

Two seat, two door, touring coachwork in glass fibre reinforced plastic having good sound dampening and thermal insulation properties with exceptional strength and resistance to corrosion. Body attached to chassis via special 'bonded in' bobbin pickup points by bolts. Luggage accommodation to rear of seats accessible from seating area and in separate compartment in boot to rear of car. Wrap around laminated glass windscreen and 'pull up' toughened glass side windows.

4—Front Suspension.

Independent front suspension by unequal length wishbones, and coil spring damper units.

5—Rear Suspension.

Independent rear suspension by Chapman strut system, incorporating coil spring damper units. Wide based lower wishbones providing lateral and longitudinal location.

6—Engine.

Four cylinder twin overhead camshaft 1600 c.c. engine.

Bore	82.55 mm. (3.250 in.)	Stroke	72.746 mm. (2.864 in.).
Cubic Capacity	1558 c.c. (95.19 cu. in.)	Compression ratio	9.5 : 1.
Net horse power rating	105 b.h.p. at 5,500 r.p.m.	Firing order ...	1, 3, 4, 2.
Net torque rating	108 lb./ft. at 4,000 r.p.m.		

Special 5 bearing hollow cast crankshaft with large size integral weights dynamically balanced. Three ring pistons two-compression and one oil control ring. Fully machined combustion chambers in light alloy detachable cylinder head. Separate inlet and exhaust ports for each cylinder with inlet manifolds cast integrally into cylinder head. Twin overhead camshafts carried in babbit lined bearings with spring loaded adjustable chain tensioner. Oil pump, distributor and fuel pump mechanically driven by jackshaft from camshaft chain. High efficiency rotor type oil pump, externally mounted with pressure feed to main, big end and camshaft bearings.

Cylinder walls lubricated by oil thrown from big ends, timing chain by direct jet. Full flow filter and accessible dipstick. Water pump mounted on front face of timing chest carrying cooling fan belt driven from crankshaft. A.C. mechanical fuel pump with full flow filter. Twin 40 DCO E18 carburettors. Light alloy stove enamelled camshaft cover.

7—Clutch.

8 in. diameter spring diaphragm clutch. Dry single plate.

8—Gearbox.

Four-speed, all synchromesh with central gear change lever non-synchromesh reverse.

Overall gear ratios : Top 3.90; 3rd 5.51; 2nd 9.34; 1st 13.81; Reverse 15.45 : 1.
(Close ratios gears available as optional extra).

Gearbox lubricant capacity : 1 $\frac{3}{4}$ Imp. pints (2.1 U.S. pints, 0.99 litres).

9—Final Drive.

Chassis mounted hypoid unit, ratio 3.9 to 1; sound insulated. Fixed length final drive shafts using special rubber constant velocity universal joints, providing shock cushioning on final drive take-up. Alternative final drive ratios available as optional extras.

10—Brakes.

Girling hydraulically operated calipers on 9½-in. diameter discs on front wheels and 10-in. diameter discs on rear wheels. Facia mounted hand-brake operating on the rear discs only through cable and rods.

Brake surface area swept by linings : 358 sq. in.

11—Wheels.

Wheel type :	Bolton pressed steel four stud fixing.	
Road wheel rim size :	4.50 in.	
Tyre size :	5.20 × 13 in.	
Tyre pressures (normal touring) :	Front 18 lb. sq. in.—1.266 kg./cm.	Rear 22 lb. sq. in.—1.547 kg./cm.
(fast touring) :	Front 22 lb. sq. in.—1.547 kg./cm.	Rear 26 lb. sq. in.—1.828 kg./cm.
Recommended tyres :	5.20 × 13. Goodyear. Standard equipment.	
Other tyres :	Follow manufacturers' recommendations.	

12—Steering.

Alford and Alder rack and pinion, with telescopic and collapsible steering column. Optional right or left hand drive. 15-in. diameter dished three spoke, wood rimmed steering wheel giving 2⅔ turns lock to lock.

13—Electrical System.

12-volt Compensated Voltage Control charging system. Battery 12-volt. 57 amp./hour Positive Earth, located in accessible position behind rear of left hand seat.

Proprietary Units

Headlamps	Lucas F700	Fuse	Lucas 4 F.J.
Sidelamps	Lucas L658	Solenoid	Lucas 2 ST.
Front Flasher Lamps	Lucas L691	Heater	Smith's 2 k.w. Output ref.: FH 56444.
Rear Flasher Lamps	Lucas L539	Cigarette Lighter	Magnatex.
Stop/Tail Lamp	Lucas L551	Windscreen washer	Tudor Accessories Ltd.
Number Plate ill. lamp	London Bankside Products	Windscreen Wiper Motor	Lucas DR 2.
Horns	Lucas 9H	Generator	Lucas/Ford C4C.
Coil	Lucas LA 12	Distributor	Lucas 23D4. or 25D4.
Control Box	Lucas RB 106	Starter Motor	Lucas/Ford M35G.
		Sparking Plugs	Autolite AG32.

Bulb Replacements

Side lamps 12v. 6w. MCC No. 989.
 Dash and warning lamps 12v. 2.2w. MES No. 987.
 Stop Tail 12v. 6/21w. SBC OP No. 380.
 Front and rear flasher 12v. 21w. 35C No. 382.

14—Fuel System.

Rear mounted petrol tank of 10 Imp. gallons (45 litres) capacity. A.C. mechanical fuel pump engine driven. Flexible fuel lines. Two 30-mm. twin choke Weber 40 DCO E 18 carburettors.

15—Body Equipment

Safety harness fixing :	3-point harness mounting points.	
Carpeting :	Rubber press stud fixing on floor.	
Trim :	Washable P.V.C.	
Colours : Interior trim :	Atlas Grey and Light Tan.	
Seats :	Available in Black, Tan and Grey.	
Body colours :	Fiesta Yellow, Carmen Red, Medici Blue, Cirrus White, British Racing Green.	
Tool Kit :	Scissor jack and handle, wheel spanner and tool roll comprising :	
	Plug spanner and Tommy bar	⅜-in./7/16-in. AF Spanner
	Screwdriver	9/16-in./½-in. AF Spanner
	Adjustable spanner	Pliers.
	2 BA/4 spanner	
Ashtrays :	Indoor trim, both sides.	
Optional extras :	Tonneau cover	Heater
	Radio	Safety harness.

16—Dimensions.

Correct front wheel toe-in	$\frac{1}{8}$ in. (3·175 mm.)
Correct rear wheel toe-in	$\frac{3}{16}$ in. to zero.
Camber angle	front wheels, zero to $+\frac{1}{2}^{\circ}$.
Camber angle	rear wheels, $-\frac{1}{2}^{\circ}$ to zero.
Castor Angle (production numbers 26·3001—26·3061)	7° .
Castor Angle (subsequent vehicles)	3° .
Swivel pin inclination	9° .
Turning Circle	29 ft. 6 in. (900 cm.).
Wheelbase	84 in. (213·4 cm.).
Weight distribution (two-up)	Front 48%. Rear 52%.
Sparking plug gap	0·023 in.—0·028 in.
Distributor gap	0·014 in.—0·016 in.
Front track	$47\frac{3}{32}$ in. (1196·1 mm.)
Rear track	$48\frac{7}{16}$ in. (1230·3 mm.).
Overall length	145 in. (368 cm.).
Height to scuttle	$30\frac{1}{2}$ in. (77·5 cm.).
Normal ride ground clearance	6 in. (15·2 cm.).
Height (hood erected)	$45\frac{1}{4}$ in. (114·9 cm.).
Height to top of screen	43 in. (109·2 cm.).
Overall width	56 in. (142·1 cm.).

SECTION B

INTRODUCTION TO THE VEHICLE

	<i>Chapter</i>
Controls, switches and instruments	1
Doors, locks and windows	2
Seat adjustments	3
Care of the tyres	4
Battery	5
Hood operation	6
Running in the car	7

1—CONTROLS, SWITCHES AND INSTRUMENTS.

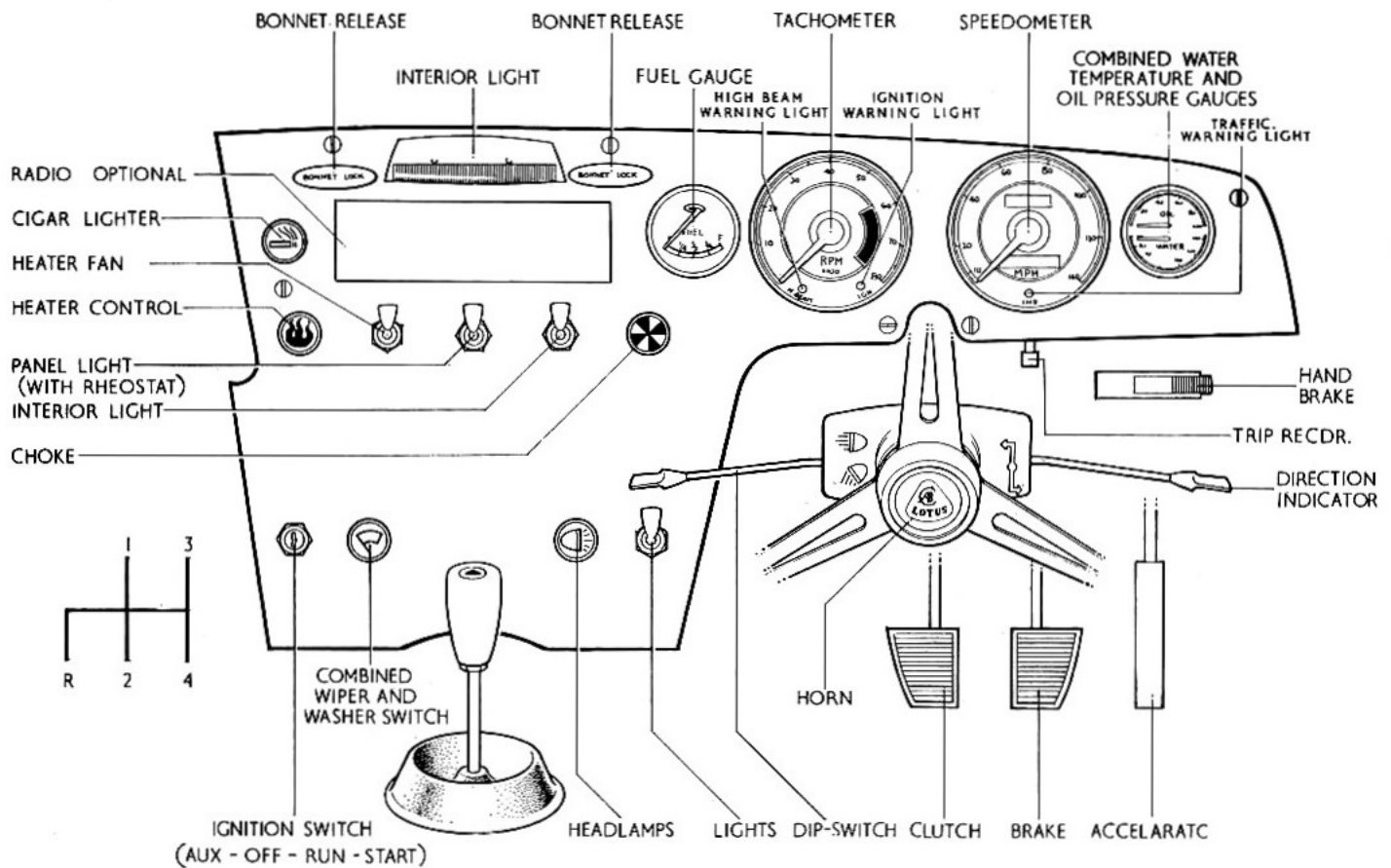

Fig. 1 Controls, Switches and Instruments.

(a) General

The ensuing chapters outline the various controls and instruments explaining the function of each. It is hoped that both service engineer and owner will familiarize themselves with the vehicle's controls and instruments and their layout so that their use becomes second nature.

It is assumed that the owner has previous driving experience and therefore no attempt has been made to provide comprehensive driving instructions.

(b) Gear Lever

The gear lever is centrally situated and comes readily to hand. First and second gears are selected by moving the lever to the left, and engaged by moving it forwards for first gear or backwards for second gear. Third and fourth gears are selected by moving the lever to the right through the neutral position until resistance is felt, then forwards for third gear and backwards for fourth gear.

To engage reverse gear, move the lever to the left in the neutral position until resistance is felt, lift the lever against the spring pressure and then move it rearwards until the stop is reached to engage the gear.

(c) Pedal Controls

The pedal controls are arranged in the orthodox positions—namely, the clutch pedal, brake pedal, and

accelerator, reading from left to right. Owners are reminded not to drive with their left foot resting on the clutch pedal. It is a bad practice and leads to rapid clutch wear. It is also inadvisable to pump the accelerator pedal when the engine is not running as this causes flooding.

(d) Handbrake

The handbrake, situated to the right hand side of the steering column, under the fascia operates the rear brake calipers mechanically.

To apply the handbrake, pull the lever back by the pistol grip. To release, pull the lever back slightly, compress the release trigger and push the lever fully forward.

Special Note.—Use of engine compression to supplement handbrake application.

It should be mentioned that owing to the "Take-up" of the flexible Rotoflex couplings on the rear drive shafts, due allowance has to be made when parking or manoeuvring. This is particularly evident when engine compression is being used to park on a hill, and it should be borne in mind that this compression will not start to act as a brake until the car has rolled downhill a foot or so. The handbrake should be applied after this condition has been attained.

(e) Ignition Switch

The ignition switch, situated to the lower passengers side of the central fascia area, is operated by a removable key, which also serves to lock the boot lid. When the ignition key is in a vertical position, the ignition is in the 'off' condition. When the key is turned clockwise to the 'first' position ignition and certain auxiliary circuits are brought into action. Turning the key past this 'first' position to a 'second' against a stop, the starter motor will operate. When the engine starts release the key immediately, which will return to the first position.

A third position, obtained by turning the key in an anti-clockwise direction will retain the use of certain auxiliary circuits but isolate the ignition. This will allow owners to operate a radio, for example, with the ignition switched off, but prevent such an accessory functioning when the key is removed.

(f) Ignition Warning Light

The ignition warning light, positioned in the lower right-hand side of the tachometer, glows red when the ignition is switched on and will go out when the generator is charging adequately. It may glow when the engine is idling, but no harm will be done so long as the engine is running.

On no account must the warning light be allowed to glow for more than a few moments with the engine stationary. Switch off the ignition immediately.

(g) Choke Control

This should only be used for initial starting from cold and is operated by pulling the control knob to the desired position. The control is locked by a half turn either way, and will hold in any position, giving a progressively richer mixture as the control is pulled out. The control must be returned to its 'rest' position as soon as the engine has started. As the carburettors fitted to the ELAN are of the automatic choke variety and preadjusted, it must be emphasised that the choke control on the fascia is really only an auxiliary expedient for the operation in conditions of cold climate.

(h) Headlamp Operation**1. Daylight Driving**

To flash headlamps for overtaking, pull knob to immediate right of gear lever. The toggle switch to the right should remain in the 'up' position. This operation cannot be performed before the engine has been run, unless the reservoir has been previously exhausted.

2. Dusk Driving

Headlamps may still be flashed as (1) with the sidelamps in the 'on' position by placing the toggle switch in the middle position.

3. Night Driving

To use full headlamps, place the toggle in the lower position and pull the knob. Use the normal dip on the left-hand side of the steering column, a foot dip switch in the case of left-hand drive models.

(i) Windscreen Wipers

To operate the windscreen wipers, rotate the wiper knob situated on the right-hand side of the ignition switch in a clockwise direction to the 'on' position. If desired the wiper speed can be decreased by turning the knob further, in a clockwise direction (through the rheostat arc) until the desired speed is obtained.

To use the screen washers, simply press the wiper knob inwards.

(j) Horn Button

The twin-tone horns are operated by pressing the central disc of the steering wheel.

(k) Heater Controls

The heater control is located above the ignition key on the left-hand side of the fascia. Temperature is controlled by pulling the knob outwards (from the Hot position when fully in), to the Cold in the fully extended position.

The demisters are fed with air at all times, but in order to dispel heavy misting, or to defrost the screen, close the flaps on either side of the heater unit under the fascia, by actuating the white toggles on these flaps with a sideways motion.

A Booster switch situated to the immediate right of the heater control knob operates the booster fan for extreme temperature conditions.

(l) Cigar Lighter

Operated only when the ignition is switched on, or to the auxiliary position, the lighter is simply pressed into its socket to heat the element. When the element has heated sufficiently, it will pop out to its rest position and may be withdrawn. To facilitate its return in the dark, a pilot light is operative in the rear of the socket when side or headlights are switched on.

(m) Bonnet Release Controls

To open the bonnet pull both hand levers marked 'bonnet lock' simultaneously on the fascia panel. This operation will release the catches and the spring loaded bonnet will open. To close, either slam the lid firmly with the hand midway between the catches or alternatively, merely press bonnet lightly local to the catch positions. In either event, ensure that both catches do engage.

In event of a cable breakage, the bonnet may still be released by unscrewing the four spire speed screws (two per side), holding the bonnet spring catches to the bulkhead. These screws are reached from under the instrument panel.

To facilitate certain overhaul procedures it is advisable to remove the bonnet. This operation is quite straightforward and its description appears in SECTION Q—Body Equipment.

(n) Steering Column Adjustment

The steering column and wheel may be adjusted in a forwards or rearwards direction to suit the driver's particular arm-length. To achieve this, it is necessary

firstly, to slacken the two bolts of the clamp securing the outer case to the facia, and secondly the two bolts on the felt lined clamp securing this case to the bulkhead. Thirdly slacken the locknut and the allen screw on the impact clamp, situated at the lower end of the outer casing attached to the inner column, and slide the wheel to the desired position.

When retightening the bolts on the clamps, care must be taken to set the wheel hub with $\frac{1}{8}$ -in. clearance to the outer casing to avoid an irritating scraping.

(o) Interior Light

The interior light is operated by the toggle switch adjacent to the choke control. This unit is incorporated in the door courtesy light circuit, and when either door is opened the interior light is illuminated. The interior light is extinguished by raising the toggle of the switch or through the usual micro-switches on closing the doors.

(p) Panel Light

This unit illuminates the instruments from the rear, and is only operative when side or headlights are switched on. The switch incorporates a rheostat and the degree of brightness may be obtained by simply lowering the toggle to the desired position. (Dim, up—bright, down).

(q) Direction Indicator

The direction indicator situated on the right-hand side of the steering column is self cancelling when the steering wheel is returned 30° from the 'full lock' position. It is only operative when the ignition is switched on. Indicators on the left front and left rear of the vehicle will flash when the indicator lever is raised from the neutral position. When this lever is lowered, the right front and right rear indicators will flash. The lever may of course be returned to its neutral position manually.

A reminder light, which flashes in unison with the indicators, is situated in the speedometer, below the trip recorder.

(r) Combined Water Temperature and Oil Pressure Gauges

Mounted on the right-hand side of the facia, the instrument consists of an oil pressure gauge in the top half and a water temperature gauge in the lower. The gauge conveys the oil pressure at the engine and its normal pressure should be 35-40 lb./sq. in. dropping to 5-10 lb./sq. in. at tickover.

The water temperature (taken from the cylinder head) should give a reading of approximately 85°C., under normal operating conditions.

(s) Speedometer

This instrument indicates the vehicle's forward speed and is graduated from 0-140 miles per hour or from 0-220 kilometers per hour. A total distance recorder is incorporated and a cancelling speedometer trip recorder is also included in this instrument.

The trip recorder is cancelled back to zero by pushing the milled knob situated beneath the speedometer head under the facia, in an upwards direction and turning clockwise.

(t) Tachometer

The tachometer is of the electrical impulse type and given an accurate indication of the engines revolutions

per minute. The dial is calibrated to 8,000 r.p.m. and incorporates a danger margin of 1,500 r.p.m. marked in red from 6,500 r.p.m. Great care must be exercised to ensure that the 6,500-8,000 r.p.m. margin is used only momentarily or in conditions of emergency. The instrument also includes headlamp high beam and ignition warning lights.

(u) Fuel Gauge

The fuel gauge, operative only when the ignition is switched on, indicates approximately the amount of fuel in the 10 Imp. gallons (45 litres) tank.

2—DOORS, LOCKS AND WINDOWS.

(a) Door Locks

Doors are locked from the outside in turn by the ignition, 'boot', door key, from inside by simply raising the interior door handles. The doors may also be locked by raising interior handle and closing door while depressing exterior push button.

(b) Boot

The boot is locked by the same key from the outside and is opened by turning anti-clockwise at the same time giving slight pressure downwards to relieve the resistance offered at the lock by the weather sealing strip.

(c) Window Operation

To open the side windows push in a downwards direction on the metal finger table secured to the top of the window glasses. Slight resistance will be felt due to the sealing action of the weather strip. The counter-balance mechanisms only compensate for the weight of the windows.

(d) Window Locks

These are provided for cars fitted with hard-tops.

3—SEAT ADJUSTMENT.

The seats are adjustable in four positions of two coarse adjustment settings giving a total of eight positions. They are so designed that when moved in a forward direction the seat is raised. To adjust, depress the flat projection of the spring loaded notched quadrant to be found on the outside of each seat and slide to the desired position. The seat may be bodily tipped forward and may be removed by removing the bolts which secure the clamping plates.

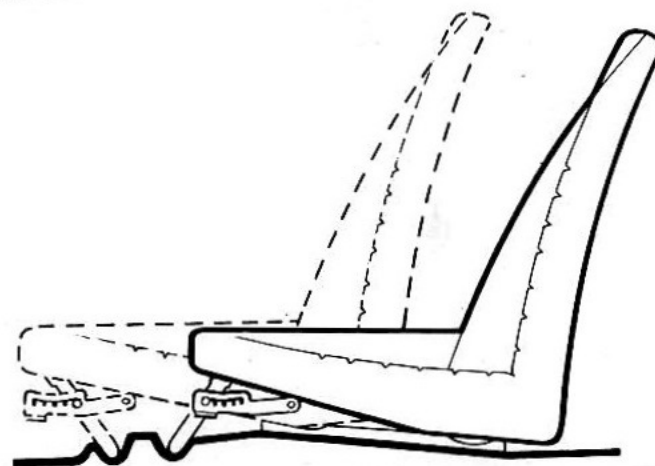

Fig. 2 Seat Adjustment

4—CARE OF THE TYRES.

(a) Wheel changing

In order to get the longest life from the tyres, the road wheels should be changed round and the spare brought into use every 2,000 miles (3,200 km.). Wheels should be repositioned as follows to equalise wear:

Spare to right rear: Right rear to left front: Left front to left rear: Left rear to right front: Right front to spare wheel position.

Maintain the tyres at the correct pressures. Under inflation will cause excessive tyre wear and rapid deterioration of the tyre walls, whilst over inflation will have a detrimental effect on the handling characteristics. Pressures should be checked at least once a week.

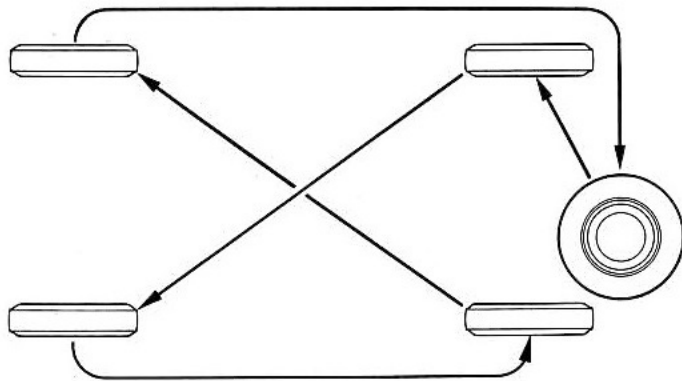

Fig. 3 Wheel Changing Diagram.

(b) Removing the Wheels

Remove the wheel disc by inserting the flattened end of the wheelbrace into the recesses between the cover and wheel, with a sideways motion of the brace. Apply the handbrake, slacken the four nuts securing the road wheel to the hub, raise the car to lift the wheel clear of the ground, remove the nuts, and withdraw the wheel. When refitting, make certain that wheel nuts are tight, final tightening being more safely done when the car is standing on its wheels.

(c) Jacking the Vehicle

To raise the rear of the car, chock the front wheels, place the scissor jack with its crutch under the wishbone cross member of the rear suspension and wind in a clockwise direction. (To lower, turn anti-clockwise). To raise the front of the car, apply the handbrake and/or chock the rear wheels, locate the hole in the top of the jack crutch under the anti-roll bar mounting stud of the front suspension lower wishbone, and wind up jack in a clockwise direction. (To lower, turn anti-clockwise). Under no circumstances whatsoever attempt to raise the vehicle from other points than shown in fig. 4 and 5.

To raise complete car use trestle support points as shown on fig 6.

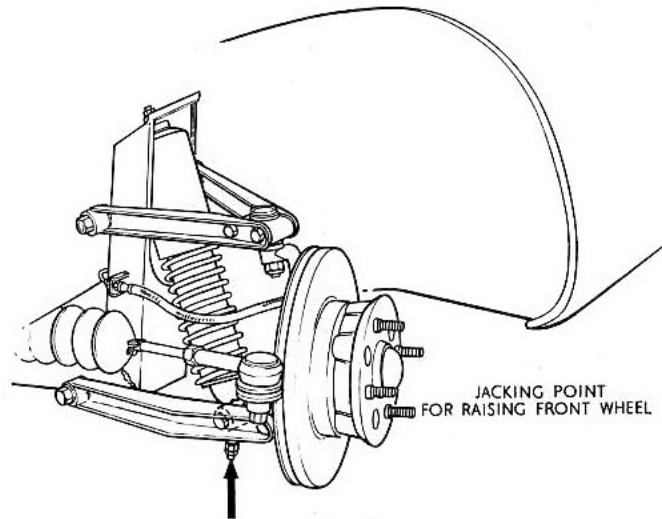

Fig. 4

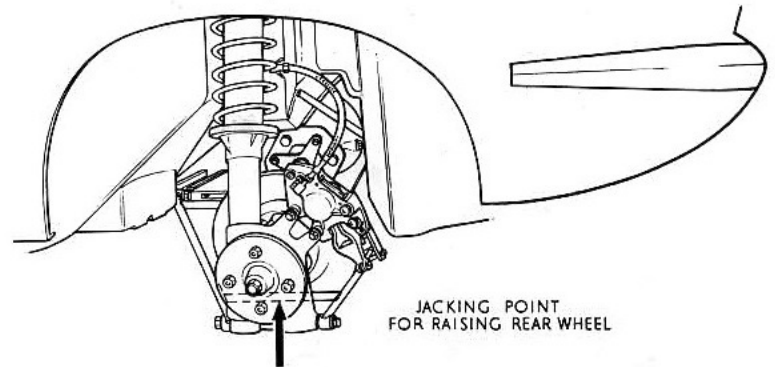

Fig. 5

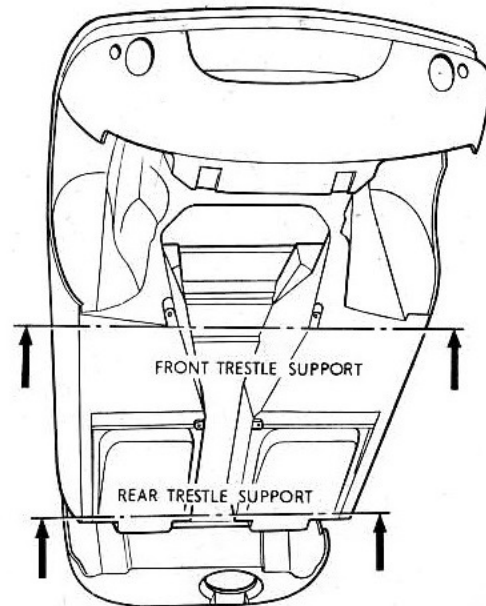

Fig. 6

(d) Wheel Balancing

During the vehicle's use it will be found that tyre wear will affect the balance of the wheels, and these should be checked and balanced at frequent intervals, depending on conditions and nature of use.

5—BATTERY.

The battery, accessible to the rear of the passenger's seat, should be examined once per week to ensure that the electrolyte level in each cell is approximately $\frac{1}{4}$ in. above the top of the plates. If it is found to be below this level, top up with distilled water. Keep the battery filler plugs and connections tight and the top of the battery clean. Wipe the exterior of the battery with a clean rag before replacing cover. Complete cleanliness is essential whilst servicing the battery inside the vehicle to ensure that no acid is accidentally deposited on the trim of the car with its inherent harmful results.

Comprehensive maintenance instructions are to be found in Section L, Electrical Equipment.

6—HOOD OPERATION.**Recommended procedure for hood erection and removal**

- Erection:*
1. Remove cant rails from boot.
 2. With doors open slide cant rail pegs into eye bolts at front with cant rail rear pegs visibly over bobbins in body, press pegs into bobbins at rear and fasten the adjacent Terax fastener. Now close the doors.
 3. Remove hood and hood sticks from boot by undoing side straps and central strut. (Refix central strut to support boot lock).
 4. Fix front hood sticks into cant rail bobbins. Twist the cant rail by hand to assist bobbin lining up if necessary.
 5. Hook rear hood sticks over cant rail rear hood sticks fixings and allow to hang.
 6. Lay hood on rear deck behind cockpit and hook the stiffening bar in the rear seam of the hood over the hood hooks, making sure that the sealing flap is laying forward and not trapped.
 7. Pull hood over sticks and push front edge of hood into windscreen groove ensuring hood is central. This is done by lining up central seam of stitching or centre mark with the windscreen tie, or other centre mark or be working from one side to the other.
 8. Do up all fasteners.
 9. From inside, revolve rear hood stick into retaining flap thus tensioning the hood.
 10. Do up rear stick securing flap fasteners.
- Removal:*
1. Undo rear stick securing flap fasteners.
 2. Push rear hood stick backwards to relax hood.
 3. Undo all fasteners.
 4. Unhook rear of hood from hood hooks on body.

5. Remove hood pulling forwards out of windscreen groove.
6. Fold hood along 'canvas' straps between the three rear windows in straight lines to front of hood.
7. Roll hood from rear to front leaving about a foot unrolled, and place in boot.
8. Remove rear hood sticks.
9. Remove front hood stick.
10. Place together, superimposed, in hood and finish rolling.
11. Lay top ends of hood straps on lamp guards over boot opening and press hood and sticks, centrally into gaps over lamp guards.
12. Secure central strut.
13. Do up hood retaining straps.
14. With doors slightly open, remove cant rails.
15. Place together, inside to inside, with pegs and studs at same ends and push into cant rail retaining strap under the rear deck with the curve facing forwards and to the right until the ends tuck under the boot opening guttering.

Ensure strap is sitting neatly under rails and not strained out of straight which might tend to push it back over guttering.

N.B.—The hood should not be folded in a wet condition as this could have a detrimental effect on the material. The use of detergents in cleaning the hood is not recommended. Road grime should be removed with clear water and a soft brush, drying off finally with a chamois leather.

7—RUNNING-IN THE CAR.

Do not exceed 3,000 r.p.m. for first 500 miles.

Equivalent to:

- 50 m.p.h. in top gear.
- 35 m.p.h. in 3rd gear.
- 21 m.p.h. in 2nd gear.
- 9 m.p.h. in 1st gear.

Avoid racing or idling the engine for long periods, particularly when warming up.

Do not allow engine to labour but use gears freely.

Remember the gearbox is not being run-in if you stay in top gear.

Avoid fast acceleration. This is extremely important as the particularly high torque can impart very high loadings not only on engine parts but also on those of the gearbox and rear drive. This causes lubrication breakdown and gives metal to metal contact with disastrous results to the running-in of newly machined surfaces.

Avoid sudden or fast stops. Use brakes gently to allow brake pads to bed in uniformly.

SECTION C

SERVICE INFORMATION

	<i>Chapter</i>
General Information	1
Initial Service, 500 miles (800 km.)	2
"A" Service every 1,500 miles (2,400 km.)	3
"B" Service every 3,000 miles (4,800 km.)	4
"A" Service every 4,500 miles (7,200 km.)	5
"C" Service every 6,000 miles (9,600 km.)	6
"A" Service every 7,500 miles (12,000 km.)	7
"B" Service every 9,000 miles (14,400 km.)	8
"A" Service every 10,500 miles (16,800 km.)	9
"D" Service every 12,000 miles (19,200 km.)	10

FILE NOT TO BE REDISTRIBUTED FOR PROFIT ORIGINAL COPYRIGHT HOLDER LOTUS CARS LIMITED 1966

1—GENERAL INFORMATION.**The Lotus Maintenance Service**

In order to maintain this vehicle in an efficient, safe and economical running condition regular and thorough servicing is most essential. The Lotus Voucher Scheme has been introduced with the object of providing this service. This scheme covers lubrication, oil changes, etc., using the factory recommended lubricants. In addition to this however regular mechanical maintenance is also included to comply with the recommendations laid down by technical staff of Lotus Cars Ltd.

The Lotus maintenance service commences on a new vehicle with a free service which is given at 500 miles. Further vouchers are contained in this book to cover lubrication and the maintenance which in our opinion is necessary at 1,500-mile stages to and including 12,000 miles. Service after 12,000 miles will recommence with a new voucher book at 1,500 miles. Before the last voucher has been completed you are advised to obtain a new book from Lotus Service. These books may be presented at any authorized Lotus Service Department throughout the United Kingdom or abroad.

It is important to note that the vouchers must be used in their correct sequence at intervals of 1,500 miles, as if one type of service is omitted accidentally or otherwise the sequence of maintenance operation will be disturbed.

All customers are respectfully reminded that the manufacturers and servicing organisations of Lotus do not accept responsibility for loss or damage to motor vehicles, accessories, or other goods while in their hands for garage, storage, repair, sale or other purpose, whether occasioned by fire, frost, burglary, theft, impact or in any other way. This condition extends to customers' vehicles, attachments and contents while being driven by members of their staff or while standing outside their premises. All fees and charges due to Lotus are payable before customers remove their property from the premises.

It should be emphasised that the Lotus Service Department is better equipped with every facility to carry out service and repairs than the owner-driver. An exchange scheme for many major items and assemblies is run by Lotus Service, the prices of which can be obtained on request.

Lotus reserve the right to alter prices and specifications any time without notice and work undertaken is subject to cost and conditions ruling at the time of service.

2—INITIAL SERVICE 500 miles (800 km.).

- Lubrication:**
1. Drain engine and gearbox unit and refill.
 2. Check timing chain tension.
 3. Grease or oil lubrication points.
 4. Check cylinder head holding down bolts.
 5. Check valve clearance.

6. Examine water hose connections and radiator level.
7. Check all manifolds, exhaust system, engine mountings and distributor fittings.
8. Check throttle openings on carburettors and reset if necessary.
9. Lubricate throttle linkages and carburettor controls.
10. Check carburettor mountings for correct vertical movement.
- Clutch:** 11. Check correct operation of clutch.
12. Check clutch fluid reservoir level. (Correct level is marked on reservoir).
- Brakes:** 13. Check braking system for operation and correct adjustment.
14. Check and tighten brake disc securing bolts and caliper mountings.
15. Check braking system lines for security and for leaks.
16. Check brake fluid reservoir level. Correct level is marked on reservoir.
17. Check handbrake for correct operation and adjust if necessary after adjustment of normal system.
- Steering:** 18. Check that all steering connections are secure.
19. Check steering rack and pinion mountings for tightness.
20. Check front wheel alignment.
- Suspension:** 21. Check wishbone and damper connections on front and rear suspension units.
- Transmission:** 22. Check propshaft universal joints.
- Fuel System:** 23. Check outboard drive couplings.
24. Check fuel pipe unions.
- Electrical System:** 25. Check headlamp retracting mechanism.
26. Examine electrolyte level of battery and top up if necessary, check and tighten terminals.
27. Check electrical system thoroughly and operation of all circuits, including voltage regulator output.
28. Check distributor and sparking plug gaps.
29. Check dynamo belt tension.
30. Check windscreen wiper operation and arc.
- Body:** 31. Check body condition generally and body securing points.
32. Check door adjustments.
33. Check bonnet operation.
34. Check seat sliding mechanisms.
35. Check operation of windscreen washers.
36. Check all wheel nuts for tightness.
37. Check all tyre pressures including spares.

3—"A" SERVICE every 1,500 miles (2,400 km.).

- Lubrication:**
1. Grease or oil lubrication points.
 2. Check engine, gearbox and differential oil levels and top up if necessary.
 3. Check and lubricate if necessary throttle linkages.

- Engine:** 4. Check vertical movement of carburettors on manifolds.
5. Check slow running adjustment.
- Clutch:** 6. Check clutch fluid reservoir level and top up if necessary.
- Brakes:** 7. Check brake fluid reservoir level and top up if necessary.
8. Check brakes system and operation, including handbrake.
- Steering:** 9. Check steering assembly for general condition.
- Electrical System:** 10. Check operation of all circuits.
11. Check headlamp operation.
12. Check battery level.
- Body:** 13. Check door adjustments.
14. Check bonnet lock and operation.
- General:** 15. Check tyre pressures and wheel nuts for tightness.
16. Make visual inspection of all water hose connections.

4—"B" SERVICE every 3,000 miles (4,800 km.).

"A" Service plus the following:

- Lubrication:** 1. Drain engine and refill.
- Engine:** 2. Check valve clearance.
3. Check timing chain tension.
4. Check and adjust if necessary Fan belt tension.
- Electrical System:** 5. Clean and inspect condition of sparking plugs.
6. Check heater system and operation of valve.
7. Check distributor settings and lubricate cam and counter weights sparingly.
8. Check headlamp focus and reset if necessary.
- Steering:** 9. Check front wheel alignment and adjust if necessary.
- Transmission:** 10. Check condition and tightness of nuts and bolts on propshaft and outboard drive shafts.
- Body:** 11. Check body condition generally and attachment points.
- General:** 12. Change round all road wheels including spare.

5—"A" SERVICE every 4,500 miles (7,200 km.).

- Lubrication:** 1. Grease and oil lubrication points.
2. Check engine, gearbox and differential oil levels and top up if necessary.
3. Check and lubricate if necessary throttle linkages.
- Engine:** 4. Check vertical movement of carburettors on manifolds.
5. Check slow running adjustment.

- Clutch:** 6. Check clutch fluid reservoir level and top up if necessary.
- Brakes:** 7. Check brake fluid reservoir level and top up if necessary.
8. Check brakes system and operation including handbrake.
- Steering:** 9. Check steering assembly for general condition.
- Electrical System:** 10. Check operation of all circuits.
11. Check headlamp operation.
12. Check battery level.
- Body:** 13. Check door adjustments.
14. Check bonnet lock and operation.
- General:** 15. Check tyre pressures and wheel nuts for tightness.
16. Make visual inspection of all water hose connections.

6—"C" SERVICE every 6,000 miles (9,600 km.).

"A" and "B" plus the following:

- Lubrication:** 1. Drain engine and gearbox unit and refill.
2. Check differential unit and top up if necessary.
3. Repack front hubs with grease.
4. Lubricate water pump.
5. Fit new oil filter and sealing ring.
- Engine:** 6. Check cylinder head holding down bolts.
7. Check all manifolds, exhaust system, engine mountings and distributor fitting.
8. Clean petrol pump filter.
- Clutch:** 9. Check operation of clutch.
- Brakes:** 10. Check condition of all brake pads.
11. Check and tighten disc securing bolts, and caliper mountings.
- Steering:** 12. Check steering rack and pinion mountings for tightness.
- Suspension:** 13. Check wishbone and damper connections on front and rear suspension.
- Electrical System:** 14. Check windscreen wiper operation and arc.
15. Check voltage regulator output.
- Body:** 16. Check condition of Hood and Tonneau and their fitment and fastenings.
17. Check seat window mechanisms.

7—"A" SERVICE every 7,500 miles (12,000 km.).

- Lubrication:** 1. Grease or oil all lubrication points.
2. Check engine, gearbox and differential oil levels and top up if necessary.
3. Check and lubricate if necessary throttle linkages.
- Engine:** 4. Check vertical movement of carburettors on manifolds.
5. Check slow running adjustment.
- Clutch:** 6. Check clutch fluid reservoir level and top up if necessary.

- Brakes:** 7. Check brake fluid reservoir and top up if necessary.
8. Check brakes system and operation including handbrake.
- Steering:** 9. Check steering assembly for general condition.
- Electrical System:** 10. Check operation of all circuits.
11. Check headlamp operation.
12. Check battery level.
- Body:** 13. Check door adjustments.
14. Check bonnet lock and operation.
- General:** 15. Check tyre pressures and wheel nuts for tightness.
16. Make visual inspection of all water hose connections.

8—"B" SERVICE every 9,000 miles (14,400 km.).

- Lubrication:** 1. Drain engine and refill.
- Engine:** 2. Check valve clearance.
3. Check and adjust if necessary fan belt tension.
- Electrical System:** 4. Clean and inspect condition of sparking plugs.
5. Check heater system and operation of valve.
6. Check distributor settings and lubricate cam and counter weights sparingly.
7. Check headlamp focus and reset if necessary.
- Steering:** 8. Check front wheel alignment and adjust if necessary.
- Transmission:** 9. Check condition and tightness of nuts and bolts on propshaft and outboard drive shafts.
- Body:** 10. Check body condition generally and attachment points.
- General:** 11. Change round all road wheels including spare.

9—"A" SERVICE every 10,500 miles (16,800 km.).

- Lubrication:** 1. Grease or oil all lubrication points.
2. Check engine, gearbox and differential oil levels and top up if necessary.
3. Check and lubricate if necessary throttle linkages.
- Engine:** 4. Check vertical movement of carburettors on manifolds.
5. Check slow running adjustments.
- Clutch:** 6. Check clutch fluid reservoir level and top up if necessary.
- Brakes:** 7. Check brake fluid reservoir level and top up if necessary.
8. Check brakes system and operation including handbrake.
- Steering:** 9. Check steering assembly for general condition.
- Electrical System:** 10. Check operation of all circuits.
11. Check headlamp operation.
12. Check battery level.
- Body:** 13. Check door adjustments.
14. Check bonnet lock and operation.
- General:** 15. Check tyre pressures and wheel nuts for tightness.
16. Make visual inspection of all water hose connections.

10—"D" SERVICE every 12,000 miles (19,200 km.).

"A", "B" and "C" Service plus the following:

- Engine:** 1. Check condition of all engine ancillaries.
- Brakes:** 2. Check for wear on master cylinder, linkage and pedal bearings also on clutch.
- Electrical System:** 3. Check vacuum connections on headlamp operating mechanism.
4. Lubricate dynamo rear bearings.
- General:** 5. Any faults or inconsistencies in the operation of any components should be brought to the owner's attention.

SECTION D

LUBRICATION

	<i>Chapter</i>
General	1
Recommended lubricants	2
Lubrication points	3
Lubrication diagram	4
General notes	5

1—GENERAL.

The recommendations outlined in this section are designed primarily for owners who cannot avail themselves of the manufacturer's servicing facilities.

Conscientious and regular attention to the various lubrication points cannot be over emphasised. Correct lubrication with the recommended grades will ensure maximum performance and life from the components

with efficiency and reliability in operation.

The owner should follow the servicing schedules (Section C) to ensure that each component is lubricated at the correct mileage interval.

To this end, the lubrication diagram has been prepared with reference numbers included by each component indicating when service attention is necessary.

2—RECOMMENDED LUBRICANTS.

A		B	C	D
Engine Summer	Engine Winter	Gearbox	Rear Axle	Greasing Points
Castrolite	Castrolite	Castrol Hypoy Light	Castrol Hypoy Gear Oil	Castrolase L.M.
Esso Extra 20W/30	Esso Extra 20W/30	Esso Gear Oil G.P.80	Esso Gear Oil G.P.90	Esso Multi-purpose Grease H.
Mobiloil Special	Mobiloil Arctic	Mobilube G.X.80	Mobilube G.X.90	Mobilgrease M.P.
Shell X.100 20/20W	Shell Multigrade 10W/30	Shell Spirax 80 E.P.	Shell Spirax 90 E.P.	Retinax A.
B.P. Energol S.A.E. 20W.	B.P. Energol Visco-Static	B.P. Energol S.A.E. 80 E.P.	B.P. Energol S.A.E. 90 E.P.	Energrease L.2
Regent Havoline 20W	Regent Havoline Spl. 10W./30	Regent Universal Thubau 80.	Regent Universal Thubau 90.	Regent Multipurpose No. 2

Lubrication Notes—Important

On no account must fluids containing molybdenum disulphide additives be added to the gearbox because of possible leakage down the input shaft and on to the clutch.

Once the additive has become impregnated in the fly-wheel face the only method of removal is to machine the face and replace the clutch linings and pressure plate assembly.

3—LUBRICATION POINTS.**(a) Engine**

Inspect the oil level in the sump daily and refill if necessary to the 'FULL' mark on the dipstick. The oil level dipstick is located on the left side of the timing chest, whilst the oil filler cap, situated on the rear of the left-hand camshaft cover, is released by turning anti-clockwise.

The sump drain plug is located on the right-hand side of the engine. Draining operations should be carried out whilst the oil is warm (e.g. after the vehicle has returned from a journey) so that it will drain easily. Thoroughly clean the drain plug before it is refitted and tightened. Refill the engine with oil (Section A.).

The sump capacity is $6\frac{1}{4}$ pints ($7\frac{1}{2}$ U.S. pints, 3.546 litres) but a further $\frac{1}{2}$ pint (0.6 U.S. pints, 0.284 litres) can be added if the filter chamber has been emptied. Owners are recommended to renew the oil filter element every 6,000 miles and clean the filter chamber out thoroughly at the time of this oil change. The filter is released by undoing the central bolt holding it to the oil pump body on the right-hand side of the engine. The rubber sealing ring, located in the circular groove of the base of the oil pump body, must be renewed when fitting the filter element. Engine Oil Filter assembly, complete with sealing ring.

Lotus/Ford part number 105E 6714A Centre bolt torque—12/15 lb. ft.—must not be over tightened.

(b) Gearbox

A combined filler and level plug is fitted on the left-hand side of the gearbox, the drain plug being situated below the gearbox. The oil level should reach the bottom of the plug orifice, and extreme pressure oil of the correct grade added if necessary. Used gearbox lubricants should be drained at 6,000 mile intervals, preferably when the oil is warm after a run. Ensure that the drain plug is cleaned thoroughly before being replaced and tightened.

(c) Rear Axle

The rear axle should be lubricated at recommended service schedule intervals by means of the combined filler and level plug and topped up as necessary. The axle when new is filled with a special 'running in' oil and only requires additional topping up with the recommended lubricants every Service.

The filler and level plug is located on the left-hand side of the rear differential casing and is accessible between the rear of the left-hand wishbone and body.

A flexible spout or tube placed on the nozzle of the oil can will facilitate this operation.

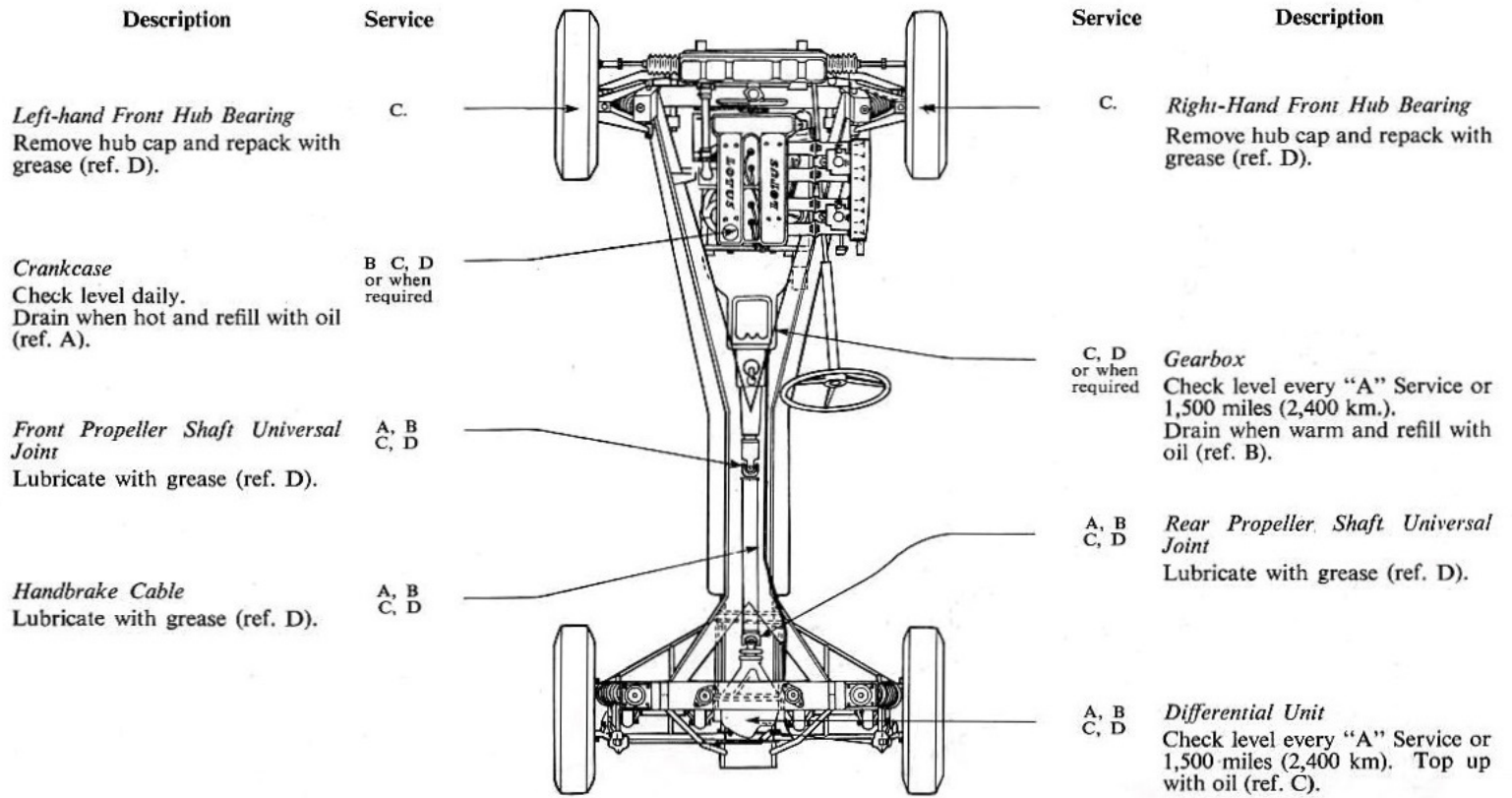

Description **Service**

Left-hand Front Hub Bearing
Remove hub cap and repack with grease (ref. D). C.

Crankcase
Check level daily.
Drain when hot and refill with oil (ref. A). B, C, D or when required

Front Propeller Shaft Universal Joint
Lubricate with grease (ref. D). A, B, C, D

Handbrake Cable
Lubricate with grease (ref. D). A, B, C, D

Service **Description**

C. *Right-Hand Front Hub Bearing*
Remove hub cap and repack with grease (ref. D).

C, D or when required *Gearbox*
Check level every "A" Service or 1,500 miles (2,400 km.).
Drain when warm and refill with oil (ref. B).

A, B, C, D *Rear Propeller Shaft Universal Joint*
Lubricate with grease (ref. D).

A, B, C, D *Differential Unit*
Check level every "A" Service or 1,500 miles (2,400 km). Top up with oil (ref. C).

CAPACITIES

ENGINE (incl. filter chamber)	GEARBOX	REAR AXLE	COOLING SYSTEM (incl. heater)
6½ pints 8·1 U.S. pints 3·83 litres	1½ pints 2·1 U.S. pints 0·99 litres	2 pints 2·4 U.S. pints 1·13 litres	14 pints 16·7 U.S. pints 7·95 litres

5—GENERAL NOTES.

Oil Can Lubrication and Servicing Periods
(using lubricant reference A).
Throttle linkages and carburettor controls; A, B, C, D.
Bonnet release cables, adjacent to catches; A, B, C, D.
Rear brake compensating mechanism; A, B, C, D.
Distributor shaft bearing and counterweights; (remove rotor arm and lubricate sparingly through hole in top of distributor shaft and through clearance hole in base plate); C, D.
Contact breaker pivot (lubricate sparingly); C, D.
Brake, clutch and throttle pedal pivots B, C, D.
Dynamo rear bearing; D.

Grease Applications and Servicing Periods
(using grease reference D).
Distributor cam, smear lightly; C, D.
Bonnet slide rails, smear lightly; A, B, C, D.
Bonnet release striker plates, smear lightly; A, B, C, D.
Boot stay, smear slide pin lightly; C, D.

Footnote : Above recommendations for touring conditions only and do not apply to competitions. Reference is made to oils used in the lubrications descriptions on this page. This reference together with the recommended lubricants in tabulated form will be found on the opposite page.

Door engagements guides and catches, smear lightly; B, C, D.

Hydraulic System—Replenishment Periods

Brake Reservoir

Check level every "A" Service or 1,500 miles (2,400 km.) and top up with Castrol/Girling 'Crimson' Hydraulic fluid if necessary.

Clutch Reservoir

Check level every "A" Service or 1,500 miles (2,400 km.) and top up with Castrol/Girling 'Crimson' Hydraulic fluid if necessary.

Special Note

Should supplies of the above brake/clutch fluid be unavailable in certain overseas territories, a fluid complying with an SAE 70 R3 specification may be used in an emergency.

Greasing Points (cont. from D.2)

(d) Greasing Points (Section D).

Front Propeller Shaft Universal Joint

Remove the right-hand front seat by unscrewing the four bolts on the clamping strips of the seat cross tube. Lift the trim on the right-hand side of the propeller shaft tunnel and insert the grease gun through the aperture on the tunnel. The joint may be rotated so that the nipple is more accessible by simply rocking the vehicle gently forwards or backwards.

Rear Propeller Shaft Universal Joint

Jack up rear of car and remove rear wheel as outlined Section B, Chapter 4b. Access to the rear propeller shaft universal joint is attained through the 'open' quarter of the chassis, local to the differential unit. The joint may be rotated so that the nipple is more accessible.

Front Hub Bearings

Access to the front hub caps is facilitated if the front wheels are removed (Section B, Chapter 4b). Care must be taken to avoid damaging the caps when removing them. If the caps are tapped lightly in an outwards direction as the hub is rotated, it should not present any problem. Pack the bearings with grease and replace caps by tapping gently into position. Replace road wheels, tighten the wheel nuts and snap on hub discs.

Distributor Cam

Unclip the distributor cap and lift the rotor off the top of the spindle by pulling it off squarely. Lightly smear the cam with a very small amount of grease.

Bonnet slide rails: smear lightly.

Bonnet stay: smear slide pin lightly.

Boot stay: smear slide pin lightly.

Door engagement guides and catches: smear lightly.

(e) Oil Can Lubrication (ref. A).

Throttle linkages and carburettor controls—lightly lubricate all throttle linkages and carburettor controls.

Bonnet release cables

Lightly lubricate the cables adjacent to the bonnet release cables.

Rear brake compensating mechanism

Remove right-hand rear wheel as outlined chapters B and C, Section B, lubricate pivot pin and clevises on swivel tree, of mechanism situated to rear of differential housing.

Distributor Cam Bearing

Unclip distributor cap, and lift the rotor off by pulling it squarely. Add a few drops of oil to the bearing via the hole in the top of the shaft now exposed. Do not remove the screw situated in the well of the shaft. There is a clearance between the screw and the inner face of the spindle for the oil to pass. Replace the rotor with its drive lug correctly engaging the spindle slot and push it into the shaft as far as it will go.

Counterweights

Add a few drops of oil through the hole in the contact breaker base plate through which the cam passes. Do not allow the oil to get on or near the contacts. Do not over-oil.

Contact breaker pivot

Add a spot of oil to the moving contact pivot pin.

Brake, clutch and throttle pedal pivots

Lubricate the pedal cross shaft sparingly and the clevises on the pedals. Add a drop of oil to the throttle cable at the point where the inner cable runs into the outer cable.

Dynamo Rear Bearing

Add a few drops of oil in the lubrication hole in the centre of the rear end bearing plate. Do not over-oil.

SECTION E**ENGINE**

	<i>Chapter</i>
The engine compartment	<i>Illustration</i>
The engine cutaway	<i>Illustration</i>
General description	1
Lubrication	2
The engine lubrication system	<i>Illustration</i>
Oil pump and filter components	<i>Illustration</i>
Oil pump and filter components	<i>Key to components</i>
Cylinder head overhaul	3
Cylinder head components	<i>Illustration</i>
Cylinder head components	<i>Key to components</i>
Camshaft and valve mechanism	<i>Illustration</i>
Camshaft and valve mechanism	<i>Key to components</i>
Major overhaul	4
Cylinder block and water pump components	<i>Illustration</i>
Cylinder block and water pump components	<i>Key to components</i>
Crankshaft, piston and flywheel assembly components	<i>Illustration</i>
Crankshaft, piston and flywheel assembly components	<i>Key to components</i>
Exhaust system	<i>Illustration</i>
Exhaust system	<i>Key to components</i>
Engine build specification	5



Fig. 1—THE ENGINE COMPARTMENT

FILE NOT TO BE REDISTRIBUTED FOR PROFIT ORIGINAL COPYRIGHT HOLDER LOTUS CARS LIMITED 1966

FILE NOT TO BE REDISTRIBUTED FOR PROFIT ORIGINAL COPYRIGHT HOLDER LOTUS CARS LIMITED 1966

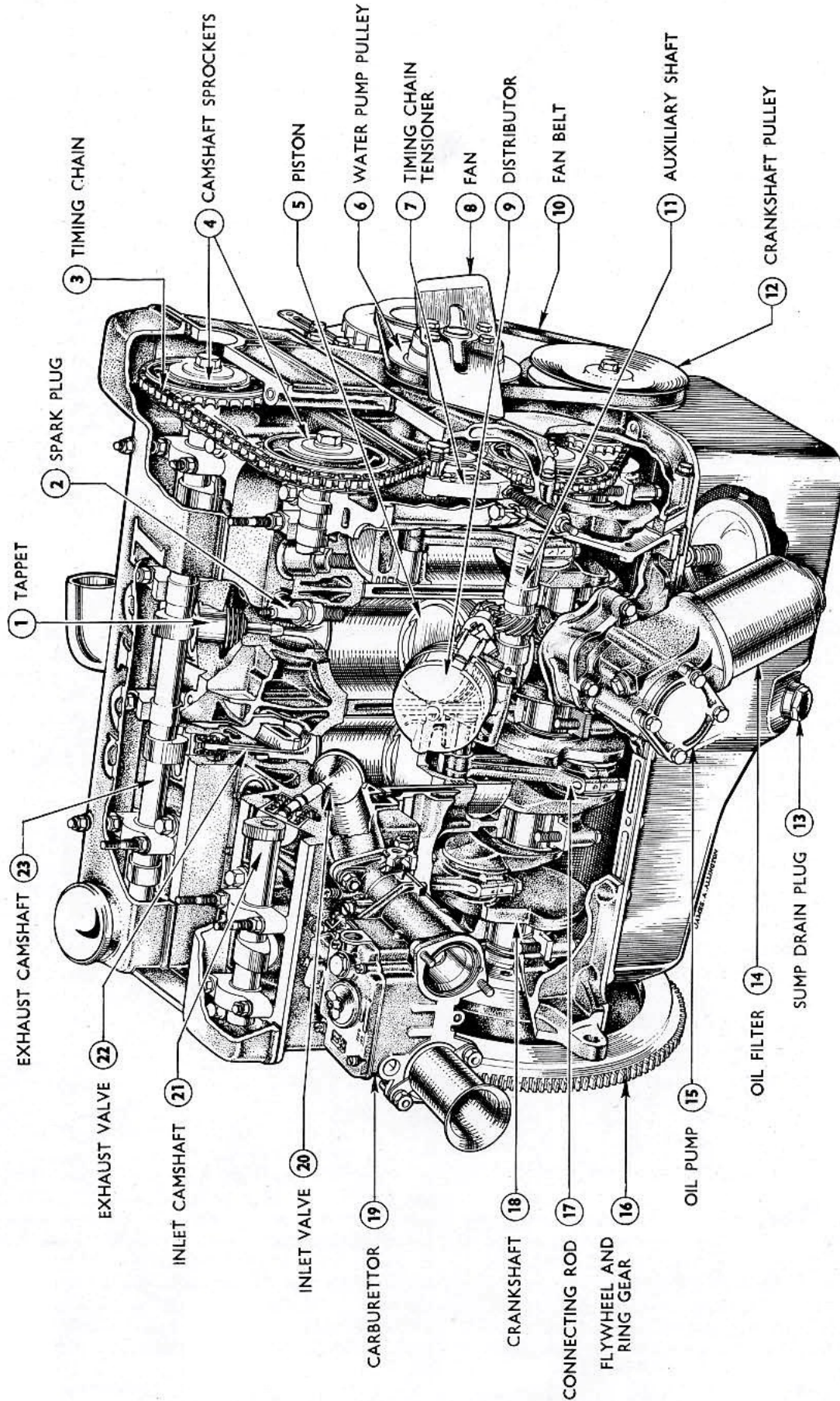

Fig. 2—THE ENGINE CUTAWAY

1—GENERAL DESCRIPTION

The engine is a four cylinder, four-stroke, twin overhead camshaft unit with a bore of 3.25 in. (82.55 mm.) and a stroke of 2.864 in. (72.746 mm.) giving a capacity of 95.06 in. (1,558 cc.) and a compression ratio of 9.5:1.

The cast aluminium cylinder head has fully machined hemispherical combustion chambers and separate ports for each valve. The valves, of which the inlets are longer than the exhaust have replaceable guides and seat inserts and are at an angle of 27° to the vertical. They are operated by the camshafts acting directly on piston type tappets. A spring tensioned single row chain drives the camshafts at half engine speed. The camshaft end float and location depends on a shoulder at the front of each shaft bearing in the head. The timing chain also drives the camshaft utilized in the pushrod overhead valve unit, which is situated in the right-hand wall of the cast iron block and is retained in order to drive the oil pump, distributor and fuel pump. The jackshaft is located by a thrust plate bolted to the cylinder block front face and runs in three, steel backed white metal bearings, while the camshafts each run in five bearings of this type. The oil pump, distributor, and fuel pump, are mounted on the right-hand side of the engine, the oil pump and distributor being driven by a single skew gear on the jackshaft and the fuel pump by a cam also on the same shaft.

The crankshaft, of hollow cast iron construction and dynamically balanced, runs in five steelbacked lead/bronze lined bearings, end float being controlled by split thrust washers located in the cylinder block on either side of the centre main bearing.

Forged connecting rods of "H" section having steel backed bronze little end bushes and steel backed lead/bronze big end liners are utilized, the big end end bearing caps being located by two dowels and retained by two bolts and tabwashers. Solid skirt aluminium alloy pistons with two compression and one oil control ring situated above the gudgeon pin are used. The gudgeon pins themselves are retained in position by circlips installed in grooves at each end of the gudgeon pin bore.

The externally mounted eccentric bi-rotor oil pump incorporates a non-adjustable plunger type relief valve.

The cast iron flywheel which ensures a vibration free engine incorporates a steel gear drive for the starter motor.

For water pump description see cooling system, Section N.

2—LUBRICATION

(a) General

The lubrication system is of the forced feed type (see fig. 3) the oil being circulated by a mechanically driven oil pump. Oil is drawn from the sump up an inlet pipe attached to the cylinder block and into the pump. When the relief valve described in chapter 1 opens, oil is passed back into the sump, returning via the base of the sump to prevent aeration. From the pump

the pressurised oil flows through the integral full flow filter to a short oil gallery on the right-hand side of the engine. At the forward end of the gallery is a tapped take-off for the oil pressure gauge pipe. A cross drilling at the rear of this gallery takes the oil to the other side of the engine where the main oil gallery is situated from which all the main bearings are fed. A notch cut in the centre main bearing liner feeds oil to the crankshaft rear thrust washer. Oil is fed to the big end bearings through drillings in the crankshaft, front, centre and rear journals. Lubrication of the little end bushes, the gudgeon pins, and the non-thrust sides of the cylinders is carried out by a jet of oil forced through a small drilling in each connecting rod web every revolution of the crankshaft.

The jackshaft bearings are fed from the front, centre and rear main bearings via drillings in the block and a metered jet of oil from a front drilling lubricates the chain and sprockets. Oil fed to the overhead camshafts is controlled by flats machined on the jackshaft front journal, and each camshaft bearing is then fed by a central drilling, blocked at the rear end by a tapered Allen screw. Surplus oil from these bearings then drains back into the sump by way of passages in the head.

(b) Oil Level

Provisions are made on the front left-hand side of the engine for a dipstick in the form of a metal tube pressed into the timing case cover. When checking the oil level the car must be standing on a level surface and the dipstick withdrawn, wiped, replaced and finally withdrawn and read, the depth of oil on the end of the dipstick indicating the level of the oil in the sump. If oil needs to be added, remove the oil filler cap on the rocker cover and pour in clean engine oil of the correct grade until the dipstick indicates that the sump is full. Do not overfill. From new the oil should be changed after 500 miles (800 km.) and then after every 2,500 miles (4,000 km.). If the oil appears to be excessively dirty before this distance, it should be changed and a new filter element fitted. The sump capacity is 6½ imp. pints (7½ U.S. pints, 3,546 litres) but a further ½ imp. pint (0.6 U.S. pint 0.284 litre) must be added for a dry oil filter. Where possible it is best to drain the oil when the engine is warm and has a lower viscosity to carry away any sediment.

(c) The Oil Filter

As previously mentioned in chapter 2(a) a full flow filter is employed, bolted to the pump body to make an integral unit. The oil flows through the filter and passes to the galleries. To remove the filter unscrew the central retaining bolt and withdraw the filter body and element (see fig. 4). The element should be replaced whenever the oil is changed or more frequently if there are signs of excessive fouling. Extract the sealing ring and fit the replacement ring supplied with the new element by forcing on at four diametrically opposed points simultaneously. Clean out the filter body and refit the new filter assembly to the pump body.

FILE NOT TO BE REDISTRIBUTED FOR PROFIT ORIGINAL COPYRIGHT HOLDER LOTUS CARS LIMITED 1966

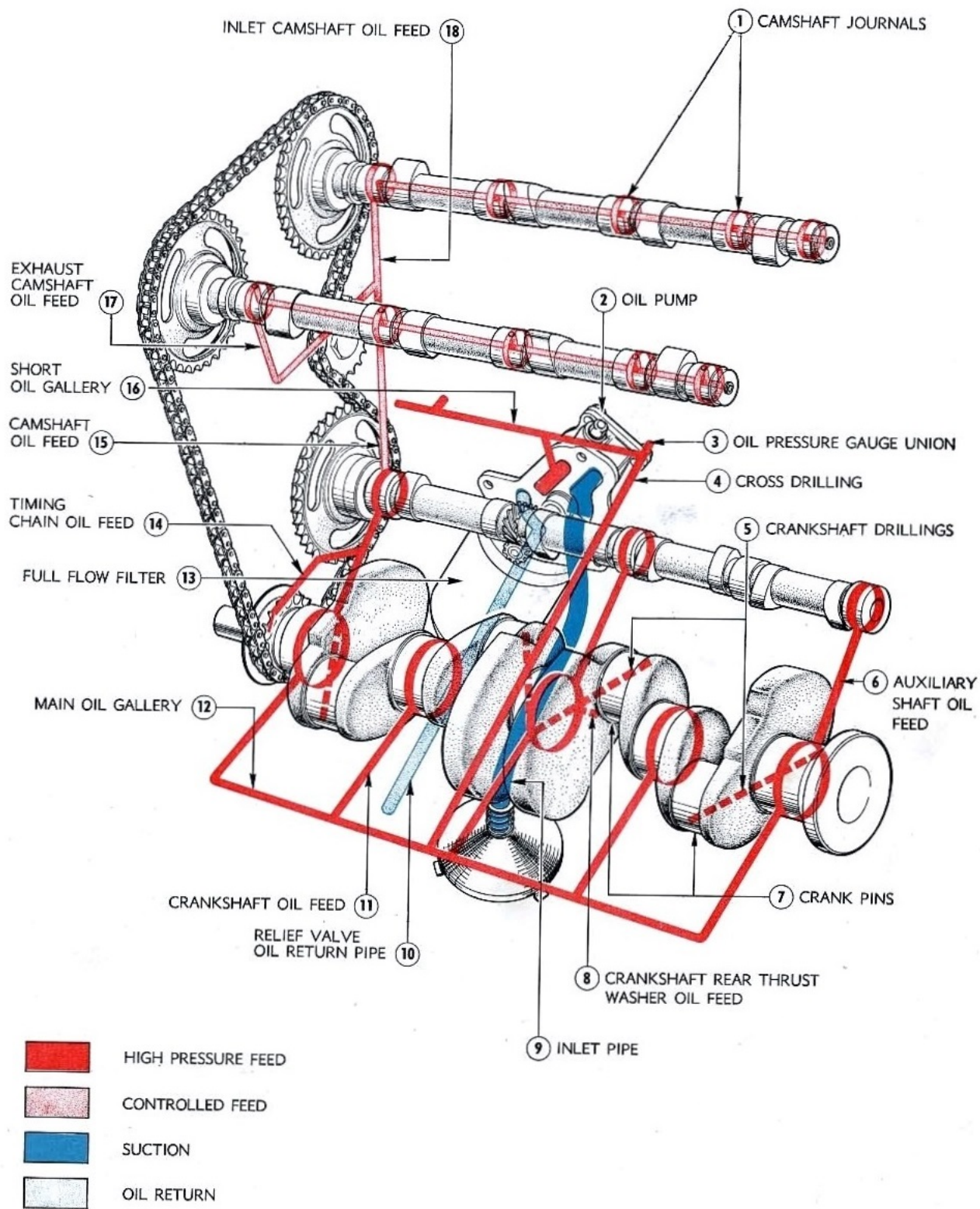

Fig. 3—THE ENGINE LUBRICATION SYSTEM

FILE NOT TO BE REDISTRIBUTED FOR PROFIT ORIGINAL COPYRIGHT HOLDER LOTUS CARS LIMITED 1966

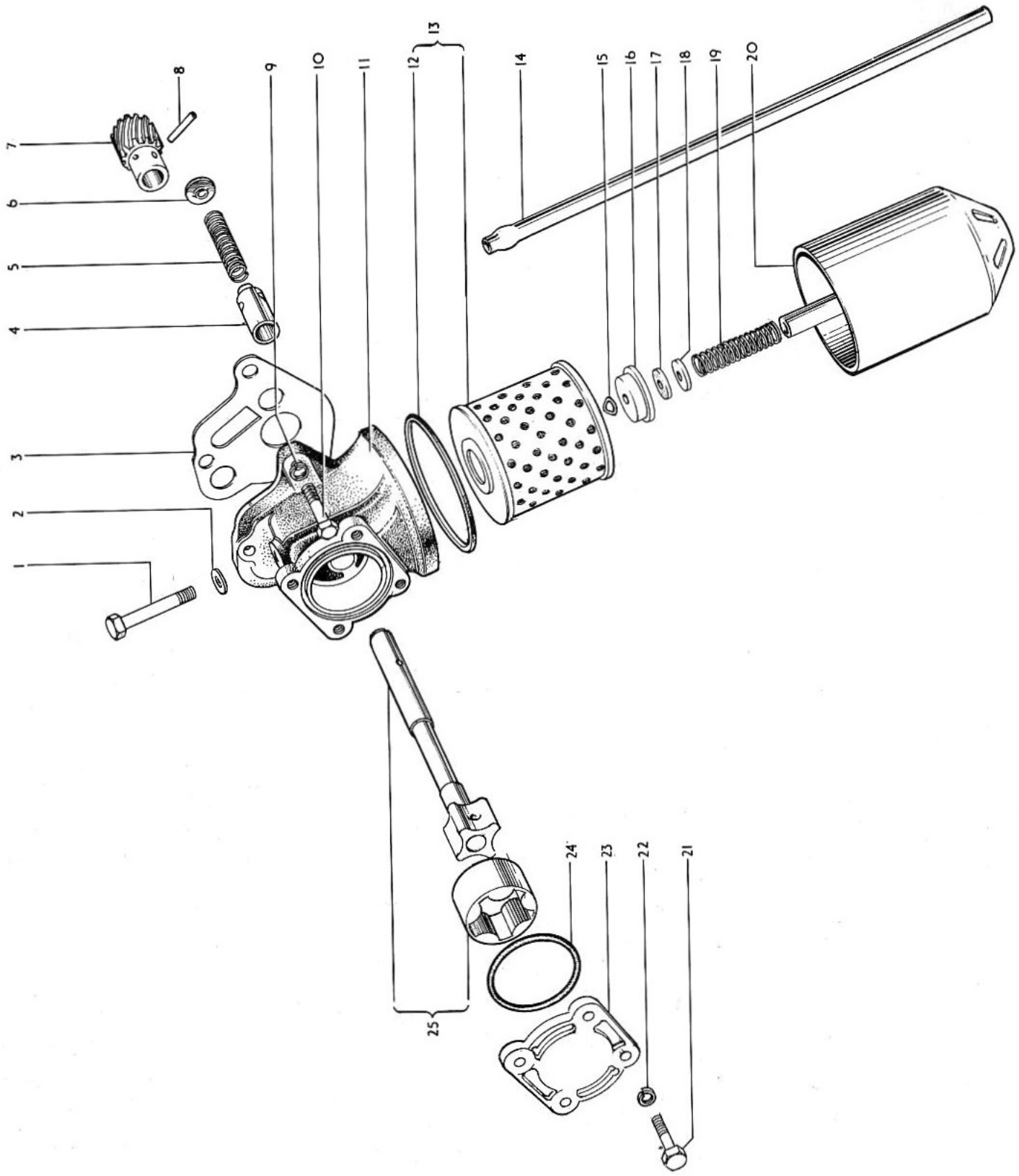

Fig. 4—OIL PUMP AND FILTER COMPONENTS

KEY TO OIL PUMP AND FILTER COMPONENTS

Key No.	Description	Key No.	Description
1	Bolt (oil filter to oil sump)	14	Pipe (oil pump relief valve return)
2	Washer	15	Ring (oil filter case to oil pump body)
3	Gasket (oil pump to cylinder block)	16	Seat (oil filter element retaining spring)
4	Plunger (oil pump to relief valve)	17	Gasket (oil filter element seal)
5	Spring (oil pressure relief valve)	18	Washer (oil filter element seal)
6	Retainer (oil pressure relief valve)	19	Spring (oil filter element retaining)
7	Gear (oil pump drive)	20	Case (oil filter) assembly
8	Pin (gear to shaft)	21	Bolt (cover to body)
9	Lockwasher	22	Lockwasher
10	Bolt (oil pump to cylinder block)	23	Cover (oil pump)
11	Body (oil pump) and filter relief valve assembly	24	Ring (oil pump cover sealing)
12	Gasket (oil filter case to oil pump body)	25	Rotor (oil pump) and shaft assembly
13	Filter (assembly) (Tecalemit F.P. 3315)		

(d) The Sump

The sump is of pressed steel construction with a capacity of $6\frac{1}{4}$ imp. pints, bolted to the block with 18 bolts, the rear-most pair of which are longer than the others. Spring and thick flat washers are used, the flat washers being of great importance as they distribute the load and prevent distortion.

(e) The Oil Pump

The oil pump is so positioned that it can be removed without lifting out the engine, being bolted to the right-hand side of the cylinder block.

The pump is of the self priming type and the pressure relief valve mentioned in chapter 1 and chapter 2 (a) is set to limit the pressure to 35 to 40 lb/sq. in. (2.46 to 2.81 kg/sq. cm.).

The pump is of the bi-rotor type consisting of two rotors in the pump body. The inner driving rotor has four lobes and is eccentrically mounted to mesh with an outer driven rotor which has five internal segments. Rotation of the inner rotor by the jackshaft skew gear causes rotation of the outer rotor, lifting the oil from the sump.

To remove the pump and filter unit from the engine unscrew the three, securing bolts, withdraw the drive shaft and remove the gasket.

Remove the filter body as described in (2 c) and extract the sealing ring from its groove in the filter body mounting flange. Unscrew the four bolts retaining the end cover and remove this and the rubber "O" ring, so exposing the rotors. Turn the rotor shaft until the inner rotor is so positioned that two of its segments straddle any one lobe of the outer rotor and check the clearance between two opposite segments of the inner rotor and the two corresponding lobes of the outer rotor. Then turn the rotor a few degrees more until one segment of the inner rotor is standing squarely between two lobes of the outer rotor. It will be found that the opposite segment of the inner rotor will be opposite the highest point of one of the outer rotor lobes. The clearance at this point should be checked. In both cases it should not exceed 0.006 in. (0.152 mm.). The clearance between the outer rotor and the pump body should not exceed 0.010 in. (0.254 mm.). Excessive clearance means that a new rotor assembly must be fitted, as they are supplied as a matched pair.

In cases of extreme wear between pump body and rotor a new pump may be necessary. The clearance between the face of the rotors and a straight edge placed across the pump face should not exceed 0.005 in. (0.127 mm.). Excessive clearance can be cured by lapping the pump body face.

To remove the inner rotor and drive shaft which are serviced as an assembly, the skew gear must first be removed by driving out the retaining pin.

Assuming that the pump has been completely dismantled, reassembly starts with the replacement of the inner rotor, drive shaft, skew gear and pin which should be peened over to prevent loosening in service. Replace the outer rotor with its chamfered face inwards, and the rubber "O" ring and the end cover, bolted on with 4 bolts and lockwashers, machined face inwards.

Fit a new filter body seal in the manner described in 2 (c) and attach the filter body and element, renewing the aluminium sealing washer if necessary. Finally place a new gasket on the pump mounting flange and secure with three bolts and lockwashers.

3—CYLINDER HEAD OVERHAUL

(a) Removing the Cylinder Head

Having detached the bonnet undo the flexible pipe clip connecting the filter to the air box. Undo the air box clamping bolt and remove the airbox and gasket. Disconnect the fuel pipe and throttle return spring and unscrew the eight self-locking nuts retaining the carburettors to the inlet manifold. Remove the carburettors and "O" ring gaskets, keeping the two carburettors as an assembly. Drain the engine, disconnect the top hose and remove the water pipe. Disconnect the thermometer capillary tube, heater control valve, heater exit pipe, plug leads, vacuum take-off and oil breather pipe situated adjacent to the rearmost inlet manifold branch. Remove the exhaust manifold to downpipe clamp, and detach the exhaust manifold by undoing the special brass self-locking nuts.

Unscrew the eight self-locking nuts and plain washers securing the camshaft cover, lift the cover and gasket and remove the four semi-circular neoprene plugs. Remove the camshaft sprockets by undoing the central retaining bolts and let the timing chain fall into the timing chest, then remove the bolts holding the timing chest to the head. Unscrew the head bolts in the order shown in fig. 4. Lift off the head and remove the gasket. Note that No. 1 bearing cap must be removed before the adjacent cylinder head bolt can be unscrewed. Do not lay the cylinder head down on its face while the camshafts are still fitted as any valve that is open may be damaged. If the head is going to be stored for any length of time it is recommended that all bearing cap nuts be slackened off to their limit to relieve the valve springs. If the camshafts are going to be removed then the camshaft bearing caps must be removed. Unscrew the bearing cap nuts evenly and remove the bearing caps, camshafts and bearing liners, taking care to note the bearing liner sequence. Using a valve grinding sucker or some similar instrument withdraw the tappets and then the tappet shims. These should also be kept in sequence. Using a suitable valve spring compressor force the valves down and extract the split collets. This will allow the removal of the spring retainers, valve springs, valve and spring seats.

(b) Decarbonizing

Plug the water ways of the cylinder head with a clean rag. If special equipment is not available for decarbonizing it will be necessary to scrape the carbon deposit from the piston crowns, cylinder block and cylinder head, using a blunt scraper.

A ring of carbon should be left round the periphery of the piston crown and the rim of carbon round the top of the cylinder bore should not be touched. To facilitate this an old piston ring can be sprung into the bore so that it rests on top of the piston. The cylinder head is next given attention. The sparking plugs must be cleaned and adjusted. Clean off the carbon deposits from the valve stems, valve posts and combustion spaces of the cylinder head. Remove all traces of carbon dust with compressed air or by the vigorous use of a tyre pump and then thoroughly clean with paraffin and dry off. Fit a new cylinder head gasket when replacing the head if the old one had been damaged. Tighten the cylinder head bolts in the order shown in fig. 11.

(c) Valves

The valves are inclined at 27° to the vertical and have a seat angle of 45°. The inlet valves have larger diameter heads than the exhaust valves, the diameters being $1\frac{1}{8}$ in. (38.89 mm.) and $1\frac{5}{16}$ in. (33.34 mm.). Double valve springs are employed and they sit on pressed steel seats located around the valve guides which are retained by the valve guide circlips. The springs are attached to the valve stems by spring retainers with split tapered collets. The valve springs may be fitted either way round.

To check the clearance of a valve first turn the camshaft until the heel of the cam is on the tappet and then, using feeler gauges, determine the distance between the tappet and the heel. The clearances should be 0.005 to 0.006 in. (0.127 to 0.152 mm.) for inlet valves and 0.006 to 0.007 in. (0.152 to 0.178 mm.) for exhaust valves. Adjustment of the valve clearances can be effected only after the camshafts have been removed, following the procedure outlined in Chapter 3 (a). Clearance may then be altered by changing the shims found between the tappet blocks and the valve stem.

When reassembling the valve gear, note that the camshaft bearing cap nuts should be tightened to a torque of 12 lb./ft. (1.7 kgm.).

(d) Valve Grinding

Remove the valves as in Chapter 3 (a), clean each thoroughly and carefully examine for pitting. Valves in a pitted condition should be refaced with a suitable grinder or new valves should be fitted. Stamp any new valve with the number of the port to which it is fitted. If the valve seats show any signs of pitting or unevenness they should be trued by the use of special service cutting tools. When using a cutting tool take care to remove only as much metal as is necessary to ensure a true surface.

When grinding a valve onto its seating the valve should be smeared lightly with fine or medium grade carborundum paste and then lapped in with a suction grinder. Avoid the use of excessive quantities of grinding paste and see that it remains in the region of the valve seating only. A light coil spring placed under the valve head will assist considerably in the process of grinding. The valve should be ground to its seat with a semi-rotary motion and occasionally allowed to rise by the pressure of the light coil spring. This assists in spreading the paste evenly over the valve face and seat. It is necessary to carry out the grinding operation until a dull, even, matt surface free from blemishes is produced on the valve seat and valve face. On completion the valve seats and ports should be cleaned with a rag soaked in paraffin (Kerosene) dried and then thoroughly cleaned by compressed air. The valves should be washed in paraffin and all traces of grinding paste be removed.

When necessary replace the valve seat inserts. Old valve seats may be removed by inserting a suitable sharp chisel through the port and carefully locating its cutting edge between the base of the insert and the alloy material of the head. The chisel may then be tapped deftly with a hammer. Further similar attempts to dislodge the insert should be made round the periphery of the insert where access is possible. Interference fit of both exhaust and inlet inserts is 0.0025/0.0045 in. so for easy replacement a temperature difference between head and inserts of at least 180°C. is necessary. The cylinder head must on no account be heated to more than 200°C. and any heating must be evenly distributed throughout the casting. Subsequent cooling should be slow and even in air. The inserts must not be cooled below 80°C. (approx. 5 mins. in dry ice). It is important that the inserts seat well and truly against the bottoms of the recesses in the head. The recesses must be free of foreign matter which would otherwise prevent this. Details of the standard and oversize valve seat inserts are shown in tabulated form here together with the appropriate boring limits.

VALVE SEAT INSERTS

INLET

Part No.	Size	Dimensions	Recess diameter
26E312	Standard	1.6245 in.—1.6235 in.	1.621 in.—1.620 in.
26E312A	+ .005 in.	1.6295 in.—1.6285 in.	1.626 in.—1.625 in.
26E312B	+ .010 in.	1.6345 in.—1.6335 in.	1.631 in.—1.630 in.
26E312C	+ .015 in.	1.6395 in.—1.6385 in.	1.636 in.—1.635 in.

EXHAUST

Part No.	Size	Dimensions	Recess diameter
26E313	Standard	1.4995 in.—1.4985 in.	1.496 in.—1.495 in.
26E313A	+ .005 in.	1.5045 in.—1.5035 in.	1.501 in.—1.500 in.
26E313B	+ .010 in.	1.5095 in.—1.5085 in.	1.506 in.—1.505 in.
26E313C	+ .015 in.	1.5145 in.—1.5135 in.	1.511 in.—1.510 in.

To remove the valve guides lay the head with its machined face downwards on a clean surface and either drive the valve guide upwards into the tappet bore with a suitable sized pilot drift and preferably using an accepted method of heat application.

Valve guides are best fitted at the same time as the valve seat inserts, the circlips first having been fitted to the guides. The guides must be correctly positioned axially in the head by ensuring that the circlips seat completely in the recesses. Care must be taken that the guides are not driven beyond this point.

Apart from the standard size, two oversize valve guides are available for the Lotus twin cam power unit.

VALVE GUIDES

INLET

Size	Limits	Part No.
Standard	.5005 in.—.5000 in.	A 26 E 314
+ .001 in.	.5015 in.—.5010 in.	A 26 E 314 A
+ .005 in.	.5055 in.—.5050 in.	A 26 E 314 B

EXHAUST

Size	Limits	Part No.
Standard	.5005 in.—.5000 in.	A 26 E 315
+ .001 in.	.5015 in.—.5010 in.	A 26 E 315 A
+ .005 in.	.5055 in.—.5050 in.	A 26 E 315 B

To re-assemble the valves first lubricate each valve stem and insert each valve into the head. Add the spring seats, inner and outer springs and spring retainer to each valve in turn, completing the assembly by compressing the springs and locating the split collets in the grooves. With the correct thickness shims in place, fit the tappets over the valves, dropping each into its respective bore. Locate the camshaft bearing liners in their correct positions, the tongues on the liners bearing in the seats machined in the blocks. Add the camshafts bolting on the camshaft bearing caps in correct order to a torque reading of 12 lb.ft. (1.658 kgm.). Check the valve clearance. Do not add the camshaft sprockets until the head has been bolted to the block.

Inlet and exhaust sprockets are similar in appearance, but the timing mark on the exhaust sprocket is in a different position. This sprocket is marked "EX" to avoid confusion. Fit the sprockets on their respective camshafts with their timing pointing inwards towards each other and level with or slightly below the top face of the head. Take up the slack in the timing chain so that there is a maximum lift of $\frac{1}{8}$ in. (12.7 mm.) on the horizontal section of chain between the inlet and exhaust camshaft sprockets.

KEY TO CYLINDER HEAD COMPONENTS

Key No.	Description	Key No.	Description
1	Oil filler cap	16	$\frac{5}{16}$ in. plain washer
1a	Gasket (special rubber)	17	Gasket (timing case to cylinder head)
2	Camshaft cover assembly comprising :	18	Gasket (cylinder head)
3	$\frac{1}{4}$ in. nut nylon type "T" (camshaft cover retaining)	19	Union connector vacuum take off $\frac{1}{8}$ in. B.S.P.
4	$\frac{1}{4}$ in. plain washers (camshaft retaining nuts)	20	Stud (inlet manifold mounting)
5	Gasket (camshaft cover assembly to cylinder head assy.)	21	Breather tube
6	Bearing cap (camshaft)	22	Breather grommet
7	Expansion plug $\frac{3}{4}$ in. diameter	23	Plug vacuum servo take off $\frac{1}{8}$ in. B.S.P.
8	$\frac{3}{4}$ in. B.S.P. aluminium crush washer	24	Ring dowel (bearing cap to head)
9	$\frac{1}{4}$ in. B.S.P. plug—oil gallery blank	25	Stud (short—camshaft bearing cap)
10	Washer (cylinder head clamping bolt)	26	Stud (long—camshaft bearing cap and camshaft cover assembly)
11	Clamping bolt (cylinder head)	27	Bolt (cylinder head)
12	Cylinder head assembly	28	Washer (cylinder head bolt)
13	Plug (camshaft bore)	29	Washer (cylinder head bolt) (special)
14	$\frac{5}{16}$ in. U.N.C. bolt x $1\frac{1}{4}$ in. (cylinder head to timing case cover)	30	$\frac{5}{16}$ in. plain washer (bearing cap to head)
15	$\frac{5}{16}$ in. spring washer	31	$\frac{5}{16}$ in. nut Nyloc type "T" (bearing cap to head)

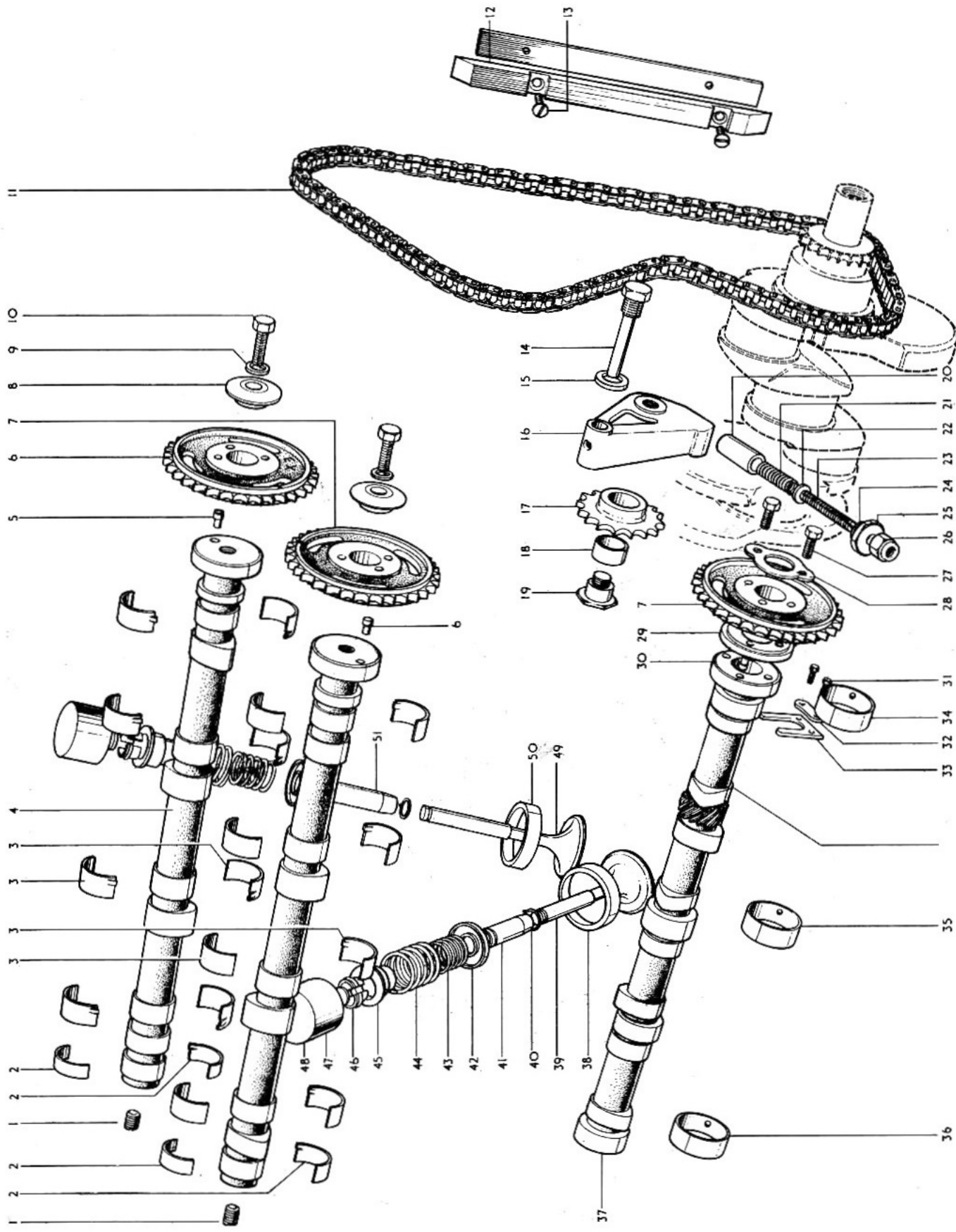

Fig. 6—CAMSHAFT AND VALVE MECHANISM

FILE NOT TO BE REDISTRIBUTED FOR PROFIT ORIGINAL COPYRIGHT HOLDER LOTUS CARS LIMITED 1966

KEY TO CAMSHAFT AND VALVE MECHANISM

Key No.	Description	Key No.	Description
1	$\frac{1}{8}$ in. B.S.P. Allen plug (taper)	26	$\frac{1}{8}$ in. nut Nyloc type "T" (adjustment screw)
2	Camshaft bearing (rear)	27	Bolt (camshaft sprocket and jackshaft)
3	Camshaft bearing	28	Retainer (camshaft sprocket and dowel)
4	Camshaft	29	Sprocket adapter (jackshaft)
5	Dowel (camshaft sprocket to camshaft)	30	Dowel (jackshaft)
6	Sprocket (Exhaust camshaft)	31	Bolt (camshaft thrust plate)
7	Sprocket (camshaft)	32	Retainer (camshaft thrust plate bolt)
8	Sprocket washer (camshaft)	33	Plate (camshaft thrust)
9	$\frac{1}{16}$ in. spring washer (.062 max. thick)	34	Liner (camshaft bearing front)
10	Bolt (camshaft sprocket to camshaft)	35	Liner (camshaft bearing centre)
11	Timing chain	36	Liner (camshaft bearing rear)
12	Vibration damper	37	Jackshaft
12a	Packing piece	38	Valve seat insert (inlet)
13	$\frac{1}{4}$ in. U.N.C. slotted shallow C.S.K. screw x $\frac{1}{2}$ in.	39	Valve (inlet)
14	Pivot pin (chain tension bracket)	40	Circlip (Anderton type)
15	$\frac{1}{4}$ in. B.S.P. aluminium crush washer	41	Valve guide (inlet)
16	Chain tension bracket	42	Valve spring seat washer
17	Chain tension sprocket	43	Valve spring (inner)
18	Bush (chain tensioner)	44	Valve spring (outer)
19	Sprocket pin (chain tensioner)	45	Valve spring retainer
20	Plunger (chain tensioner)	46	Split cone collet (Bul-lock No. 8)
21	Spring (chain tensioner)	47	Tappet shim
22	Adjustment screw washer	48	Tappet
23	Adjustment screw	49	Valve (exhaust)
24	$\frac{5}{8}$ in. aluminium crush washer	50	Valve seat insert (exhaust)
25	Retaining bolt (chain tensioner)	51	Valve guide (exhaust)

(e) Exhaust Tappet Bore Sleeve

This sleeve has been introduced on units No. L.P. 1576 onwards and earlier engines should be modified if necessary, machining the exhaust tappet bores oversize to limits Drg. 26 E 711 (or relative service circular) and fitting sleeves part No. 26 E 324 to the head see fig. 7. The same heating procedure should be followed as recommended in Chapter 3 (d).

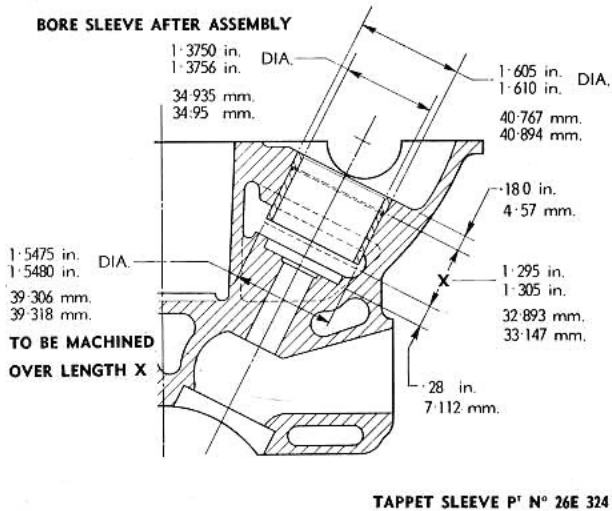

Fig. 7

*Tappet Sleeve Machining Dimensions***4—MAJOR OVERHAUL****(a) Removing the Engine from the Vehicle**

Remove the bonnet by disconnecting the two retaining springs.

Disconnect the battery leads.

Drain the oil from engine and gearbox and water from the cooling system.

The radiator drain tap is accessible from a hole in the undertray positioned in the centre, immediately below the unit. A drain tap is also situated on the left-hand side of the cylinder block. Remove the radiator. It is suggested that the gearbox is lifted out with the engine as a unit. Remove the gear lever gaiter and unscrew the gear lever unit.

Remove the top hose and bottom hoses and the radiator mounting nuts ($\frac{1}{4}$ in. Nyloc) on the underside of the body shell above the steering rack.

Remove top pipe and hose and thermostat housing (Attached by two bolts to head).

Disconnect the water temperature gauge connection.

Undo the jubilee clip and remove the hose from the heater take off point.

Disconnect the heater control valve cable at the valve.

Remove the exhaust manifold to downpipe clamp.

Undo the pipe clip and the front section of the downpipe from the rear sections.

Disconnect the choke and throttle controls at their carburettor ends.

Undo the clip and remove the vacuum take off pipe.

Disconnect the petrol supply pipe at the pump, by undoing the union, and disconnect the pipe from the pump to the carburettors in a similar manner.

Undo the flexible pipe clip from the filter to the air box.

Undo the air box clamping bolt and remove the air box and gasket.

Undo the eight Nyloc mounting nuts and remove the double spring washers from the carburettor manifold.

Withdraw the two carburettors complete with the air box from the manifold studs and remove the four "O" ring gaskets.

Disconnect the oil pressure gauge pipe by undoing the union nut at the cylinder block.

Disconnect the high and low tension leads on the coil. Lift off the trim and remove the gear change lever by unscrewing the unit at the cap.

Jack up the car and support on trestles see fig. 4, Section B.

Undo the 2BA bolts holding the exhaust pipe onto the gearbox.

Remove the four bolts holding the gearbox mounting cross member to the chassis, the two nuts holding the cross member to the gearbox and remove the cross member.

Disconnect the speedometer drive cable at the gearbox by unscrewing the knurled nut holding the cable into the right angle drive.

Remove the clutch slave cylinder (secured to the clutch bell housing) by undoing the circlip and withdrawing the cylinder through its mounting lug.

Unclip the clutch pipe from the bell housing by releasing the "P" clip held by a bolt at the top right-hand side of the housing.

Place suitable slings round the front and rear of the engine unit passing the slings round the sump.

Hoist the slings just sufficiently to take the weight of the engine unit.

Remove the four engine mounting bolts (two per side) taking note that the lower left-hand bolt secures the earth strap.

Raise the engine slightly and ease it forward until its travel is limited when the bell housing comes into contact with the engine mounting brackets on the chassis.

Tilt the engine unit over to the right-hand side of the car to clear the brackets and carefully lift the unit clear.

(b) Dismantling the Engine

Remove the ancillaries.

Remove the gearbox and bell housing.

Remove the eight Nyloc nuts of the camshaft cover and carefully remove the cover and gasket.

Remove the four camshaft bore plugs from cylinder head.

Undo the end bolts on the camshaft sprockets and pulling the camshaft sprockets forward, disengage them from beneath the timing chain.

Remove No. 1 camshaft bearing cap (its number is marked on the top of the cap).

Remove the cylinder head to timing case clamp bolt (item 11 fig. 5) and the two smaller $\frac{5}{16}$ in. clamping bolts (item 14 fig. 5) and (item 20 fig. 8).

Remove the head bolts (noting the position of the special washers).

Lift off the cylinder head taking care not to damage the chain vibration damper strip.

It should be noted that the valve heads project below the surface of the head face. To avoid accidental damage through storing the component on its face it is recommended that all bearing cap nuts be slackened off to their limit.

Remove the fan blades and pulley, fan belt, and remove the crankshaft pulley.

Undo the U.N.F. and U.N.C. set bolts and nuts from the timing case.

Carefully remove the timing case and timing chain.

Remove the jackshaft sprocket by undoing the two tab washered bolts.

Undo the single bolt retaining the timing case back plate to block and remove the backplate.

Undo the two bolts retaining the jackshaft locating plate and extract the jackshaft.

Remove the oil pump inlet by straightening the tab washer, unscrewing the union nut and withdrawing the pipe.

Remove the relief inlet valve oil return pipe with a suitable drift.

Unlock the tab washers on the big end bolts, remove the bolts and detach the big end bearing caps. Withdraw the piston assemblies by way of the cylinder bores.

To dismantle the piston assemblies first remove the piston rings, then extract the gudgeon pins by removing the retaining circlips and pushing the gudgeon pins if necessary heating the pistons in oil or water to facilitate this operation.

Remove the flywheel.

To remove the ring gear (only if replacement is contemplated), cut the gear between two teeth with a hacksaw and split with a chisel.

Mark each main bearing cap for its correct position, unscrew the main bearing cap bolts and remove the caps.

Lift out the crankshaft, the two half thrust washers located on the centre main bearing and the bearing liners.

Remove the crankshaft rear bearing oil seal and gasket.

(c) Piston Assemblies

The Lotus twin cam power unit employs a solid skirt alloy piston with valve clearance recesses machined in the head. There are three copper plated rings to each piston, two compression and one oil control ring, situated above the gudgeon pin. The two top rings must be assembled the right way up and the top of each is marked to facilitate this. The upper compression ring is chromium plated. The oil control ring may be fitted either way up. The gudgeon pins offset in the pistons .040 in. towards the thrust side of the bores to minimise piston slap, are of the tubular steel construction and are retained in the pistons by circlips in the gudgeon pin bores. Weight variation of the pistons should not exceed 4 grams in any engine. The cylinder bores of the engines are graded to give optimum fit, and the grades are given here in tabulated form.

Grade	Diameter
1	3.2500 in.—3.2503 in.
2	3.2503 in.—3.2506 in.
3	3.2506 in.—3.2509 in.
4	3.2509 in.—3.2512 in.

Pistons are graded as grades 1, 2, 3 and 4 to suit the bores. This is carried out by the piston manufacturers and the grades are stamped on the crown of the piston.

Similarly the connecting rods and gudgeon pins are graded as follows:

CONNECTING RODS

Grade	Small End Bore	Colour Code
A	0.8124 in.—0.81255 in.	Silver
B	0.81255 in.—0.8127 in.	Green

GUDGEON PINS

Grade	Diameter
A	0.8121 in.—0.8122 in.
B	0.8122 in.—0.8123 in.

Weight difference in a set of four piston assemblies, i.e. pistons, rings, gudgeon pins and connecting rods is not to exceed 6 grams.

The connecting rods are "H" section steel forgings. The detachable big end bearing caps are located by two tubular dowels and retained by two bolts which should be replaced at every engine overhaul, and two locking plates.

FILE NOT TO BE REDISTRIBUTED FOR PROFIT ORIGINAL COPYRIGHT HOLDER LOTUS CARS LIMITED 1966

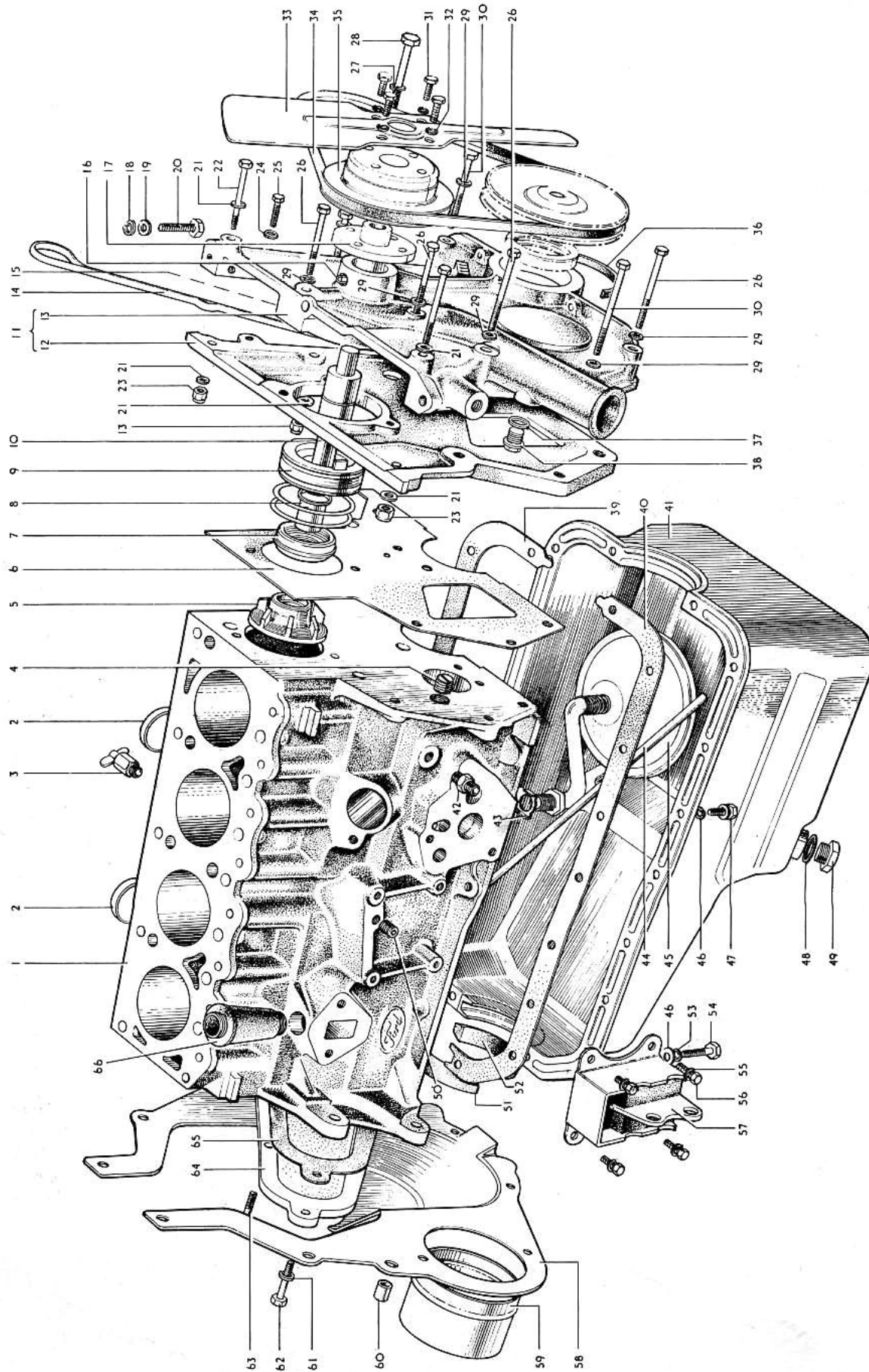

Fig. 8—CYLINDER BLOCK AND WATER PUMP COMPONENTS

KEY TO CYLINDER BLOCK AND WATER PUMP COMPONENTS

Key No.	Description	Key No.	Description
1	Cylinder block assembly complete 1560 c.c.	32	Spring washer
2	Plug (cylinder block water jacket)	33	Blade (fan) outer
3	Cock (cylinder block drain)	34	Belt (fan)
4	Plug (cylinder block oil galleries)	35	Pulley (water pump assembly)
5	Impeller (water pump)	36	Packing (front cover to sump)
6	Gasket (timing case to block)	37	$\frac{3}{8}$ in. B.S.P. aluminium crush washer
7	Seal (water pump assembly)	38	$\frac{3}{8}$ in. B.S.P. plug
8	Slinger (water pump)	39	Gasket oil pan L.H.
9	Water pump insert	40	Gasket oil pan R.H.
9a	"O" rings	41	Sump (engine oil) assembly
10	Shaft (water pump)	42	Union (oil pressure gauge)
11	Timing case assembly comprising:	43	Plate (oil pump connection lock)
12	Timing case	44	Pipe (oil relief valve return)
13	Timing case cover	45	Pipe (oil pump inlet) screen cover assembly
14	Indicator (Oil level)	46	Washer
15	Tube (oil level indication)	47	Screw (Sump to cylinder block and washer assembly)
16	Retainer (water pump bearing)	48	Gasket (sump drain plug)
17	Hub (water pump pulley)	49	Plug (sump drain)
18	Lockwasher $\frac{1}{16}$ in.	50	$\frac{1}{8}$ in. B.S.P. Allen plug (taper)
19	Plain washer $\frac{1}{16}$ in.	51	Packing (crankshaft rear oil seal) upper
20	Bolt (timing case to cylinder head) $\frac{1}{8}$ in. U.N.C. x 1 in. lg.	52	Packing (crankshaft rear oil seal) lower
21	$\frac{1}{4}$ in. plain washer (timing case cover to timing case)	53	Lockwasher
22	Bolt $\frac{1}{4}$ in. U.N.F. x 2 $\frac{1}{4}$ in. long (Timing case cover to timing case)	54	Bolt (sump to cylinder block)
23	$\frac{1}{4}$ in. nut Nyloc type "T" (timing case cover to timing case)	55	Washer (insulator to cylinder block)
24	$\frac{1}{4}$ in. spring washer (timing case to block)	56	Bolt (insulator to cylinder block)
25	$\frac{1}{4}$ in. U.N.C. set screw x $\frac{3}{4}$ in. long (timing case to block)	57	Insulator (engine front support assembly)
26	$\frac{1}{4}$ in. U.N.C. bolt x 2 $\frac{1}{4}$ in. long (timing case and cover to block)	58	Back plate (engine clutch housing)
27	$\frac{1}{8}$ in. spring washer (timing case and cover to block)	59	Cover (starter motor drive)
28	$\frac{1}{8}$ in. U.N.C. bolt x 2 $\frac{1}{4}$ in. long (timing case and cover to block)	60	Dowel (cylinder block to clutch housing)
29	$\frac{1}{4}$ in. spring washer (timing case and cover to block)	61	Lockwasher
30	Special bolt (timing case and cover to block)	62	Bolt (retainer to cylinder block)
31	Bolt (blade fan and pulley to hub water pump)	63	Bolt (retainer to cylinder block)
		64	Retainer (main bearing oil seal)
		65	Gasket (crankshaft rear oil seal housing)
		66	Neoprene breather connector (cylinder block to head)

FILE NOT TO BE REDISTRIBUTED FOR PROFIT ORIGINAL COPYRIGHT HOLDER LOTUS CARS LIMITED 1966

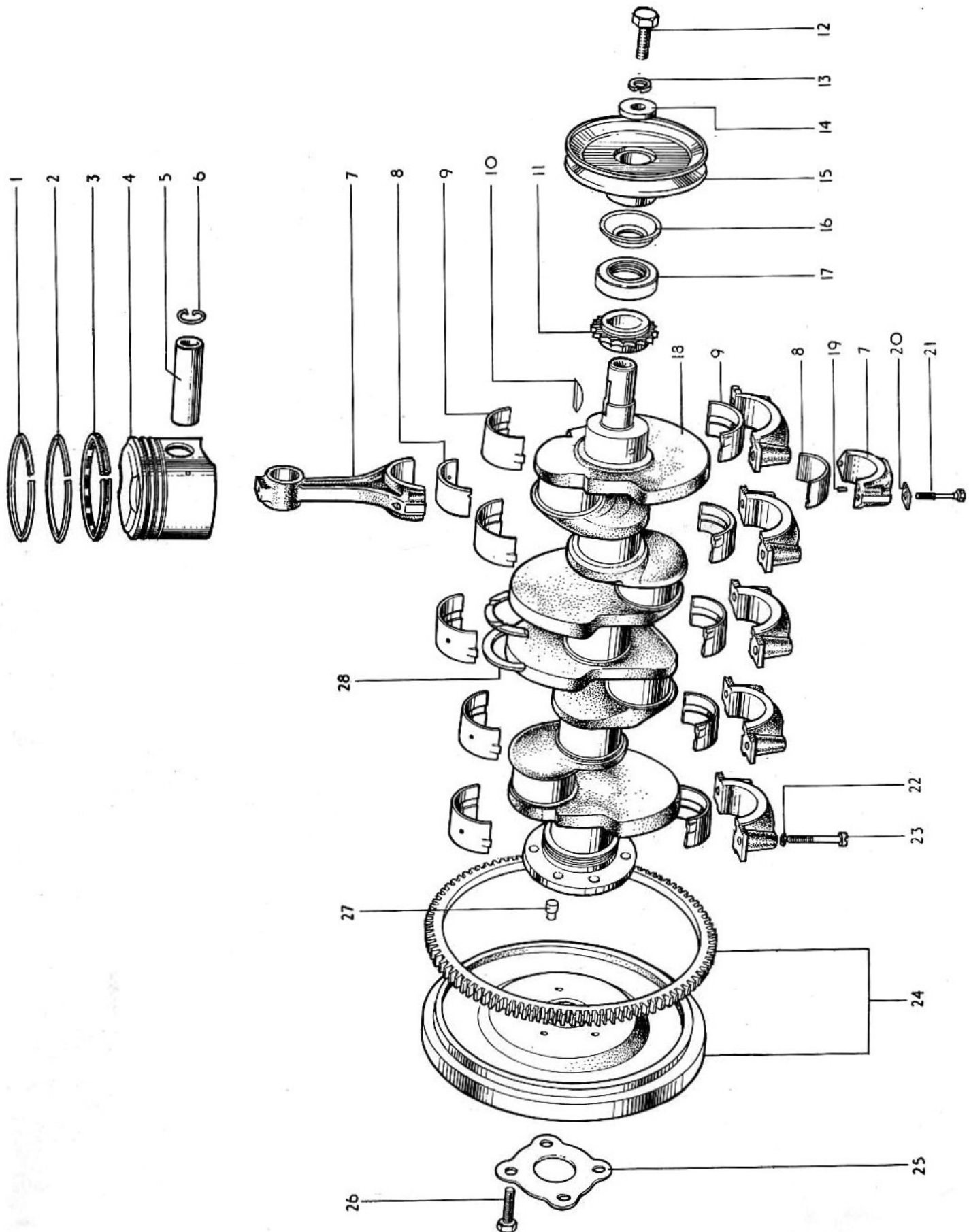

Fig. 9—CRANKSHAFT, PISTON AND FLYWHEEL ASSEMBLY COMPONENTS

KEY TO CRANKSHAFT, PISTON AND FLYWHEEL ASSEMBLY COMPONENTS

Key No.	Description	Key No.	Description
1	Ring (piston compression upper standard)	15	Pulley (crankshaft) assembly
2	Ring (piston compression lower standard)	16	Seal (crankshaft front bearing oil)
3	Ring (piston oil control standard)	17	Slinger (crankshaft oil special)
4	Piston (standard)	18	Crankshaft
5	Pin (piston)	19	Pin (connecting rod cap locating)
6	Retainer (piston pin)	20	Plate (connecting rod bolt locking)
7	Rod (connecting assembly)	21	Bolt (connecting rod big end)
8	Kit (connecting rod liner standard)	22	Lockwasher
9	Liner (crankshaft main bearing standard)	23	Bolt (main bearing cap)
10	Key (pulley to crankshaft)	24	Flywheel and ring gear assembly
11	Sprocket (crankshaft)	25	Retainer (Flywheel dowel pin and bolt)
12	Bolt (pulley to crankshaft)	26	Bolt (flywheel to crankshaft)
13	Lockwasher	27	Dowel (flywheel to crankshaft)
14	Washer (crankshaft pulley to crankshaft)	28	Washer (crankshaft main bearing thrust standard)

The big end bearing liners are of steel backed lead/bronze with a lead overlay and the little end bearings are steel backed bronze bushes lubricated through a drilling in the connecting rod by oil mist and splashes. The little end bushes are not replaceable being serviced as a unit with the connecting rod.

When dismantling the engine check the pistons for obvious signs of connecting rod misalignment. If a connecting rod is bent, straighten it or replace it with a new one.

On reassembling a connecting rod to a piston, ensure that note is taken of the marking "L FRONT" embossed on the web.

Great care must be taken to reassemble the correct big end bearing cap to the correct connecting rods. Both caps and rods are numbered to facilitate this.

(d) Crankshaft

As stated in the General Description the crankshaft is of hollow cast iron construction, dynamically balanced and runs in five plain bearings. Crankshaft thrust is taken by half thrust washers positioned either side of the centre main bearing. End float should be 0.003 to 0.008 in. To check the end float move the crankshaft rearwards to its limit and check the gap between the crankshaft and rear thrust washer with feeler gauges. To reduce end float fit the appropriate oversize thrust washers, obtainable 0.0025 in, 0.005 in, 0.0075 in, and 0.01 in. oversize.

The timing chain drive sprocket on the front end of the crankshaft is located by means of a woodruff key. Removal and replacement of this sprocket should be carried out with the use of suitable extractor and replacement tools. An oil slinger is fitted to assist the oil seal in the front cover in preventing leaks around the boss of the crankshaft pulley which is of cast iron and drives the water pump, fan and generator. The pulley is located by the crankshaft sprocket. A later type of oil slinger is available if there is not enough clearance for the timing chain.

The rear oil seal is of woven cellulose bonded with synthetic rubber and impregnated with graphite. This seal combines with a helix machined on the crankshaft to direct oil back to the sump. The seal is constructed in two halves, the upper located in a retainer bolted to the block and the lower in the sump.

The crankshaft flange has a central bore to take the clutch pilot spigot bearing.

(c) Reassembly of the Engine

It is suggested that all gaskets, oil seals and lock-washers be renewed. With the cylinder block on its back, insert the oil seals and reposition the bearing liners in their correct order, their tongues locating in the machined grooves. With the rear oil seal packing assembled snugly in the housing cut both ends .030 in. proud and parallel with the mating face of the packing retainer and sump.

Lightly lubricate the bearings and seals and the lower crankshaft into the block. Add the thrust washers either side of the centre main bearing and refit the main bearing caps, tightening the bolts to 55–60 lb./ft. (7.610–8.292 kg.m.) torque.

Check the crankshaft for free rotation. Check the crankshaft end float as described in chapter 4 (d).

If the gear ring has been removed from the flywheel a new one must be shrunk on. The ring gear must be heated to not more than 400°C. by a naked flame laying on a bed of fire brick.

The flywheel and ring gear assembly is mounted on the crankshaft flange over a sleeve in the flywheel centre which is in turn located in a bore in the rear of the crankshaft. The flywheel is keyed by a dowel to prevent movement relative to the crankshaft and is bolted to the crankshaft with 4 bolts locked by a single collective tab-washer. Flywheel retaining bolt torque should be 45–50 lb./ft.

Using a suitable gauge check that the flywheel is not more than 0.004 in T.I.R.

Replace the crankshaft sprocket.

If new pistons are to be fitted select the correct grade to suit the bore (see chapter 4(c))

Check the piston ring gaps and piston ring groove clearances. They should be as follows:

Piston ring gaps—between 0.009 in. and 0.014 in. (0.229 and 0.356 mm.).

Piston ring to groove clearances.

Upper compression ring)	0.0016 to 0.0036 in.
Lower compression ring)	(0.0406 to 0.0914 mm.)
Oil control ring	0.0018 to 0.0038 in. (0.0457 to 0.0965 mm.)

Fit the gudgeon pins to the piston/connecting rod assemblies by heating the piston and inserting the pin until it butts up against a previously fitted circlip. Lock by inserting the second circlip.

Ensure that the FRONT identification marks on both piston and connecting rod coincide.

Fit the connecting rod big end liners. Check that the lubrication drillings are correctly placed.

Space the piston ring gaps at 120° compress the rings in a suitable ring-compressing tool and insert the piston assemblies in the cylinder bores. The arrow stamped on the crown of each piston must point towards the front of the engine. Fit the big end bearing caps, tapping them onto the locating dowels and tighten the bolts to a torque of 20–25 lb./ft. (2.764–3.455 kg.m.). Bend up the tabwashers.

Slide the jackshaft into position taking care not to damage the edges of the bearings or the journals. Rotate the jackshaft to ensure that it revolves freely in its bearings.

Locate the thrust plate in the jackshaft groove and secure it to the cylinder block with the tab plate and two retaining bolts. Check that the end float is between 0.002 and 0.007 in. and bend up the tabs.

Fit the timing case back cover plate and gasket without any sealer. Having located the back cover plate on the two dowel bolts secure it with the single bolt below the water pump location.

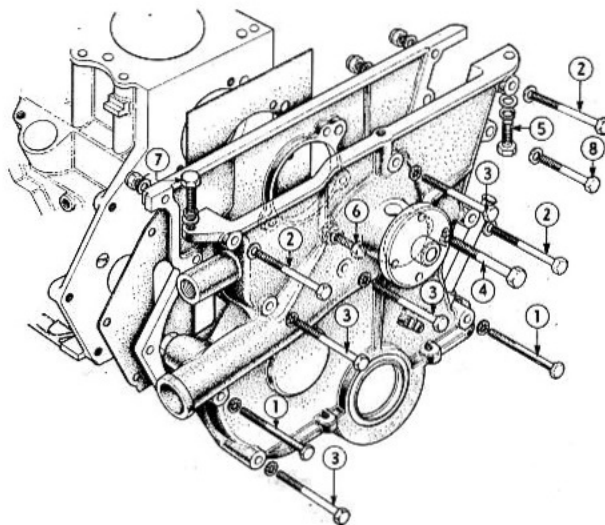

Fig. 10

Timing Chest Bolt Locations

1. Dowel Bolts $\frac{1}{4}$ in. U.N.C. \times $2\frac{1}{2}$ in. long
2. Bolt $\frac{1}{4}$ in. U.N.F. \times $2\frac{1}{2}$ in. long and nut
3. Bolt $\frac{1}{4}$ in. U.N.C. \times $2\frac{1}{2}$ in. long
4. Bolt $\frac{1}{8}$ in. U.N.C. \times $2\frac{1}{2}$ in. long
5. Bolt $\frac{1}{8}$ in. U.N.C. \times 1 in. long
6. Bolt $\frac{1}{4}$ in. U.N.C. \times $3\frac{3}{4}$ in. long
7. Bolt $\frac{1}{8}$ in. U.N.C. \times $1\frac{1}{2}$ in. long
8. Bolt $\frac{1}{8}$ in. U.N.F. \times $1\frac{1}{2}$ in. long and nut

Attach the sprocket by means of the retaining bolts and tabwasher. Mount the oil slinger on the crankshaft with its concave face towards the front. The timing chain can now be draped over the two sprockets already positioned and the water pump housing, and the timing chest front cover added, the joint being coated with a suitable jointing compound. Ensure that the correct bolts are used. Drive the oil pressure relief valve return pipe into the block, using a suitable drift. Refit the oil pump inlet pipe. Secure the oil pump with three bolts and lockwashers. Fit filter unit with new gasket.

Press the lower half of the crankshaft rear oil seal into its housing in the sump. Using a new gasket and jointing compound refit the sump, securing it with 18 bolts, lockwashers and flat washers. Replace the crankshaft pulley.

For decarbonizing of the cylinder head before assembly see chapter 3 (b).

For reassembly of the valves and camshaft see chapter 3 (c).

Ensuring that the cylinder head gasket is correctly positioned on the block and the timing chest upper gasket is in position, set the engine at T.D.C. With the camshafts also set at T.D.C. (No. 1 cylinder on compression) bolt the head to the block, tightening the bolts in the order shown in fig. 11 to a torque reading of 60 lb./ft. (8.292 kg.m.). Finally bolt the upper half of the timing chest to the cylinder head.

Fit the camshaft sprockets, exhaust first to give correct timing, and adjust the timing chain tension (section 3 (d)). Bolt on the camshaft cover. Refit the distributor and re-time the ignition in the manner outlined in Electrical Section. Screw the oil pressure gauge connection into the block. Bolt on the fuel pump with a new gasket in place, and insert the thermostat adapter into the cylinder head water outlet.

Finally fit the water pump pulley, fan, generator and fan belt, adjusted to give $\frac{1}{2}$ in. (12.7 mm.) total movement between the generator and water pump pulleys.

(f) Replacement of the Engine

Replacement of the engine unit is a reversal of the procedure outlined above.

Bolt the gearbox and bell housing to the engine.

Using a suitable hoist raise the engine and lower it

into the engine compartment, manipulating the engine, pass the tail-shaft between the side of the engine mountings and into the rear engine mounting position.

Alignment of the tail-shaft and propeller shaft splines are effected through the access hole on the right-hand side of the propeller shaft tunnel.

Remove the right-hand seat and lift trim to reveal the access hole.

It should be mentioned that replacement is facilitated by engaging the services of an assistant who can guide the tail-shaft into its alignment position in the propeller shaft tunnel, as the unit is manipulated on its slings.

Bolt the engine in position, and replace the starter motor. Jack up the front of the car, remove the stands and lower the car to the ground. Fit the breather pipe, the exhaust manifold, the earthing strap, the water temperature capillary pipe the H.T. and L.T. leads, the oil pressure gauge pipe and attach the fuel inlet pipe to pump. Connect the choke and throttle controls to the carburettors then fit the air box and connect the hose.

Refit the radiator and connect the hoses, fill the radiator add lubricant to the engine and check the level.

Replace the bonnet, the gear lever unit and the gear lever gaiter.

Road test and set up engine as required.

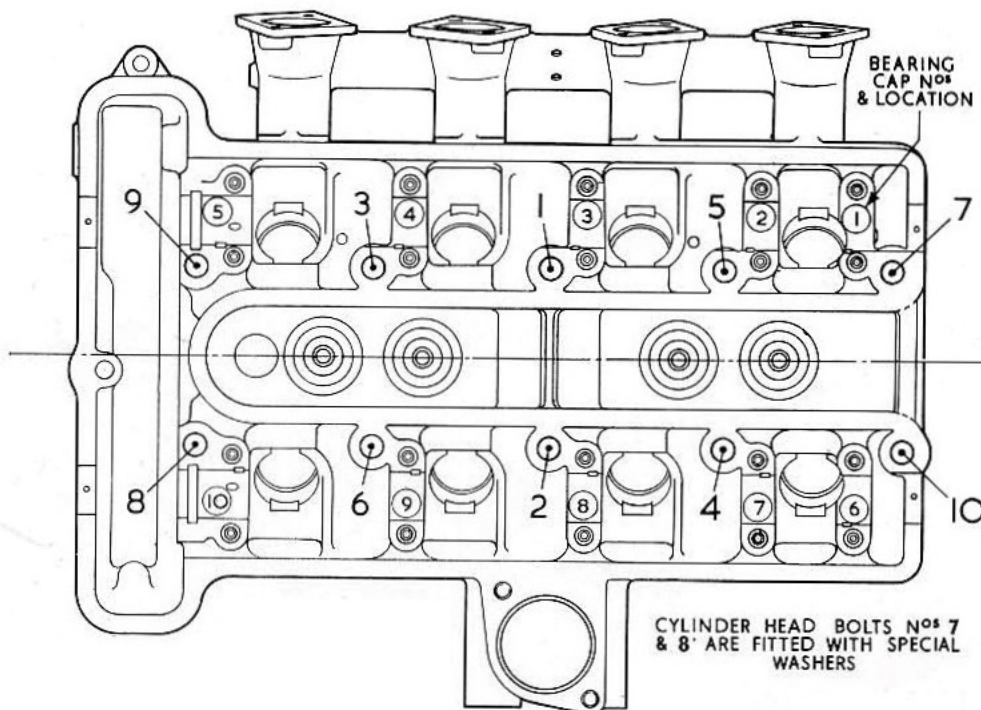

Fig. 11

Cylinder Head Bolt Tightening Sequence

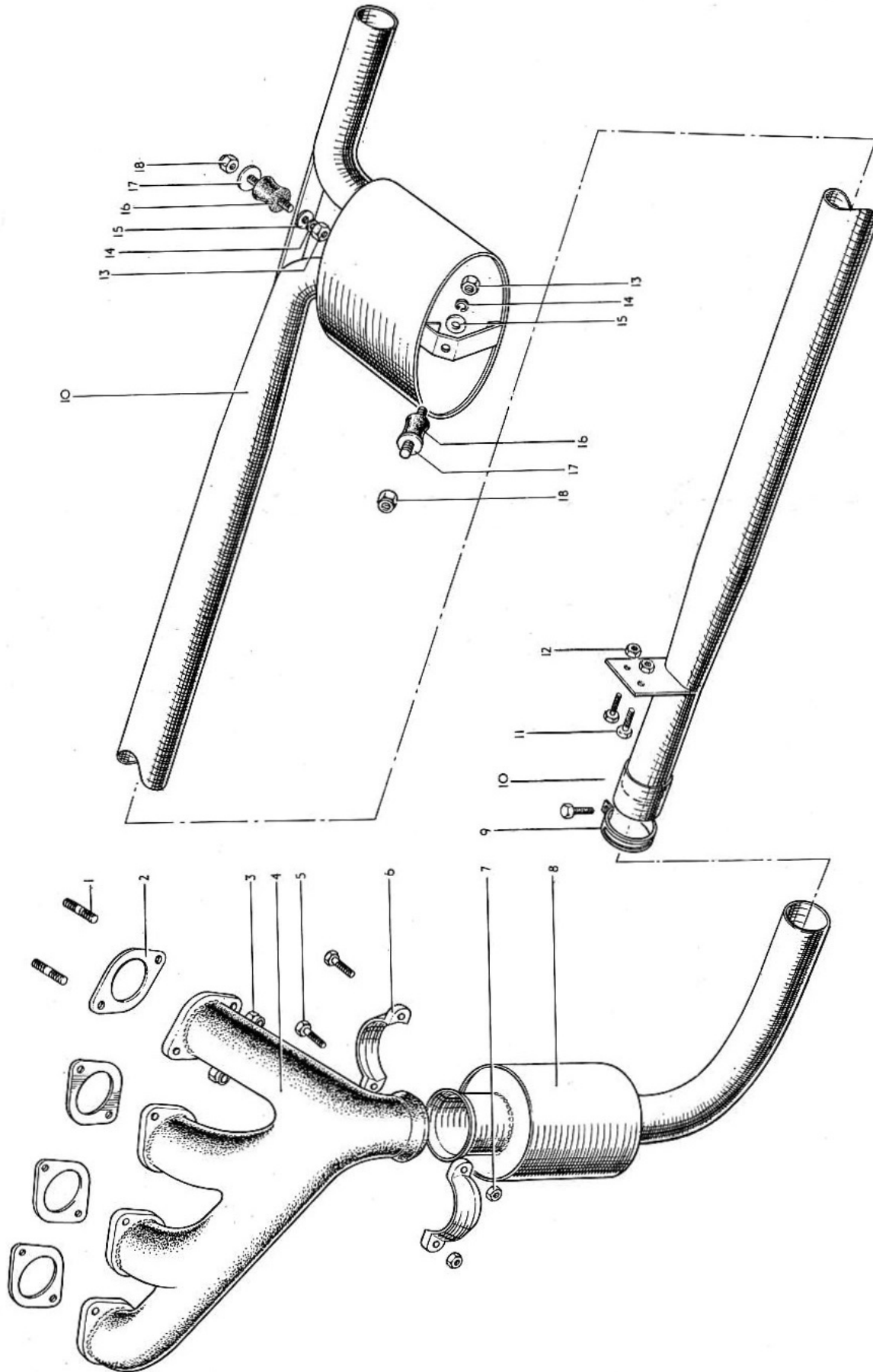

Fig. 12—EXHAUST SYSTEM

KEY TO EXHAUST SYSTEM

Key No.	Description	Key No.	Description
1	Stud	10	Exhaust pipe assembly rear
2	Gasket	11	Bolt
3	$\frac{5}{16}$ in. U.N.F. brass nuts self locking (exhaust manifold)	12	Nut
4	Exhaust manifold	13	$\frac{5}{16}$ in. nut
5	Bolt (down pipe to exhaust manifold)	14	$\frac{5}{16}$ in. spring washer
6	Clamp (down pipe to exhaust manifold)	15	$\frac{5}{16}$ in. plain washer
7	Nut (down pipe to exhaust manifold)	16	Mounting rubber
8	Exhaust down pipe	17	$\frac{5}{16}$ in. I.D. penny washer
9	$1\frac{1}{4}$ in. diameter clamp (including nut and bolt)	18	$\frac{5}{16}$ in. Nyloc nut type "T" (Simmonds)

5—ENGINE BUILD SPECIFICATION

Assembly Clearances and Limits

(a) General

Bore	3.250 in. (82.55 mm.)
Stroke	2.864 in. (72.746 mm.)
Capacity	95.19 cu.in. (1,558 cc.)
Compression ratio	9.5 : 1
Firing order	1, 3, 4, 2.

(b) Camshafts

Journal diameter	1.0000—1.0005 in.
Bearing clearance	0.0050—0.0020 in.
End float	0.0030—0.0010 in.

(c) Jackshaft

Journal diameter	1.5600—1.5605 in.
Bearing—inside diameter	1.5615—1.5620 in.
Bearing length—front	0.75 in.
centre	0.64 in.
rear	0.75 in.
Bearing clearance	0.001—0.002 in.
Oversize bearing available	0.020 in. o/son O.D. Std. on I.D.
Bearing bore in cylinder block	1.6885—1.6895 in.
End float	0.002—0.007 in.
Thrust plate thickness	0.176—0.178 in.

(d) Connecting Rods and Big End Bearings

Big end bore	2.0825—2.0830 in.
Bearing liner wall thickness	0.0719—0.07225 in.
Crankpin to bearing clearance	0.005—0.0022 in.
End float or crankpin	0.004—0.010 in.
Effective bearing length	0.83—0.87 in.
Small end bush inside diameter:			
Grade A (Aluminium)	0.8124—0.81255 in.
B (Green)	0.81255—0.8127 in.

(e) Crankshaft and Main Bearings

Main bearing journal diameter	2.1255—2.1260 in.
Main journal length—front	1.219—1.239 in.
Centre	1.247—1.249 in.
Rear	1.308—1.328 in.
Intermediate	1.273—1.283 in.
Main journal fillet radius	0.080—0.094 in.
Main bearing clearance	0.0015—0.003 in.
Block bore for bearing liners	2.2710—2.2715 in.
Crankpin journal length	1.062—1.066 in.
Crankshaft end float	0.005—0.008 in.
End float thrust washer thickness	0.091—0.093 in.
Oversize thrust washers available	0.0025, 0.005, 0.0075 and 0.0100 in.
Crankshaft balance within	0.2 oz. in.

(f) Cylinder Block

Cylinder bore standard sizes :

Grade 1	3.2500—3.2503 in.
2	3.2503—3.2506 in.
3	3.2506—3.2509 in.
4	3.2509—3.2512 in.

Grading to be measured $1\frac{9}{16}$ in. from the head face and across the block.

(g) Cylinder Head and Valve Gear

Bore for valve guides	0.4990—0.4995 in.
Valve guide inside diameter	0.3113—0.3125 in.
Valve stem diameter	0.310—0.311 in.
Valve stem to guide clearance			
(inlet)	0.0003—0.0020 in.
Valve stem to guide clearance			
(exhaust)	0.0003—0.0025 in.
Valve seat angle	45 inlet and exhaust
Bore for tappets	1.3750—1.3756 in.
Tappet outside diameter	1.3742—1.3745 in.
Tappet to head clearance	0.0005—0.0014 in.
Tappet clearance (cold) inlet	0.005—0.006 in.
exhaust	0.006—0.007 in.

(h) Valve Timing

Exhaust camshaft on full lift at 110° B.T.D.C.
 Inlet camshaft on full lift at 110° B.T.D.C.
 (Cams are symmetrical)

Outer valve spring load at 1.17 in.	45 lb.
" " " " " 0.83	109 lb.
Inner " " " " " 0.92	12.4 lb.
" " " " " 0.93	33.5 lb.
Outer valve spring fitted length (valve closed)	1.185—1.130 in.

(i) Pistons

Width of ring grooves:

Compression rings	0.0806—0.0796 in.
Oil control ring	0.1890—0.1880 in.
Width of Rings:			
Top compression ring	0.0775—0.0780 in.
2nd compression ring	0.0770—0.0780 in.
Oil control ring	0.1860—0.1865 in.
Piston bore diameter	0.8121—0.8123 in.
Piston diameter (across bottom of skirt)			
Grade 1	3.2470—3.2473 in.
2	3.2475—3.2476 in.
3	3.2476—3.2479 in.
4	3.2479—3.2482 in.
Piston clearance in cylinder bore	0.0027—0.0033 in.
Piston pin bore offset	0.04 in towards thrust face
Compression height	1.522—1.531 in.
Ring gap—compression rings	0.009—0.014 in.
oil control ring	0.010—0.020 in.
Spacing ring gaps on assembly	120° approximately

(j) Piston Pins

Length	2.80—2.81 in.
Diameter:	
Grade—A (Aluminium)	0.8121—0.8122 in.
B (Green)	0.8122—0.8123 in.
Clearance in piston	thumb push fit (selective)
Clearance in small end bush	0.0002—0.0005 in.
Set of four pistons to be within	4 grams.
Set of four pistons and con. rod assemblies to be within	6 grams.

(k) Fan

Fan blade alignment—within	0.06 T.I.R.
Balance of fan—within	0.25 oz. in.
Run out of fan pulley within	0.015 T.I.R.
Fan belt tension—deflection of belt halfway between fan and generator pulleys	0.050 in total
Run out of crankshaft pulley within	0.015 T.I.R.

(l) Water Pump

Fit of bearing in water pump housing	0.0012—0.0027 tight
Fit of shaft in water pump im- pellor	0.0050—0.0020 tight
Fit of shaft in pulley hub	0.0010—0.0025 tight

(m) Flywheel

Run out of clutch face (lateral) within	0.004 T.I.R.
Run out of starter ring gear (lateral) within	0.016 T.I.R.
Run out of starter ring gear (radial) within	0.006 T.I.R.
Clutch spigot bearing:	
Inside diameter	0.6713—0.6725 in.
Outside diameter	1.5743—1.5753 in.
Length	0.495—0.505 in.

(n) Electrical

Plugs	Lodge S HLN (Autolite AG 22)
Plug gap	0.023—0.28 in.
Distributor points gap	0.014—0.016 in.
Ignition timing (Static advance)	
distributor A26 M 009	7° B.T.D.C.
Ignition timing (Static advance)	
distributor B 26 M 009	14° B.T.D.C.

(o) Camshaft Drive

Chain tension—Total deflection at point halfway between cam- shaft sprockets	0.50 in.
Maximum run out of jackshaft sprocket	0.007 T.I.R.
Maximum run out of camshaft sprocket	0.007 T.I.R.
Maximum run out of crankshaft sprocket	0.005 T.I.R.

(p) Oil Pump

Oil pressure	35—40 lb./sq. in.
Pump body bore diameter	0.500—0.501 in.
Drive shaft diameter	0.4980—0.4985 in.
Drive shaft to body clearance	0.0015—0.0030 in.
Inner and outer rotor clearance	0.006 in. maximum
Outer rotor and housing clear- ance mfg. wear limit	0.90 in.
Inner and outer rotor end float	0.005 in. maximum
Sump capacity	6½ imp. pints
Oil filler capacity	½ imp. pint

(q) Torque Loadings

Item	Thread	Torque (lb. ft.)
Cylinder head bolts	$\frac{7}{16}$ in.—14	60—65
Main bearing cap bolts	$\frac{7}{16}$ in.—14	55—60
Connecting rod bolts	$\frac{11}{32}$ in.—24	20—25
Camshaft bearing cap nuts	$\frac{5}{16}$ in.—24	12
Flywheel to crankshaft bolts	$\frac{3}{8}$ in.—24	45—50
Oil filter centre bolts	$\frac{3}{8}$ in.—24	12—15
Camshaft sprocket bolts	$\frac{7}{16}$ in.—20	25—30
Spark plug to cylinder head	14 mm.	24—28
Sprocket pin—chain tensioner	$\frac{5}{8}$ in.—18	40—45
Retaining bolt—chain tensioner	$\frac{5}{8}$ in.—11	45—50
Pivot pin—chain tensioner	$\frac{1}{4}$ BSP.	40—45
Sump bolts	$\frac{1}{4}$ in.—20	6—8
Generator to bracket	$\frac{7}{16}$ in.—24	15—18
Crankshaft to pulley to crankshaft	$\frac{7}{16}$ in.—20	24—28
All $\frac{1}{4}$ in. bolts not scheduled above		5—7
All $\frac{5}{16}$ in. bolts not scheduled above		12—15
All $\frac{3}{8}$ in. bolts not scheduled above		10—25

SECTION F

CLUTCH

	<i>Chapter</i>
The clutch, operating mechanism and slave cylinder ... <i>Illustration</i>	
The clutch, operating mechanism and slave cylinder ... <i>Key to components</i>	
General description	1
Removing the clutch	2
Driven plates	3
Conditions of clutch facings in service	4
Clutch pilot bearing	5
Clutch release bearing	6
Overhauling the clutch pressure plate assembly	7
Replacing the clutch	8
Master cylinder	9
Slave cylinder	10
Bleeding the clutch system	11

FILE NOT TO BE REDISTRIBUTED FOR PROFIT ORIGINAL COPYRIGHT HOLDER LOTUS CARS LIMITED 1966

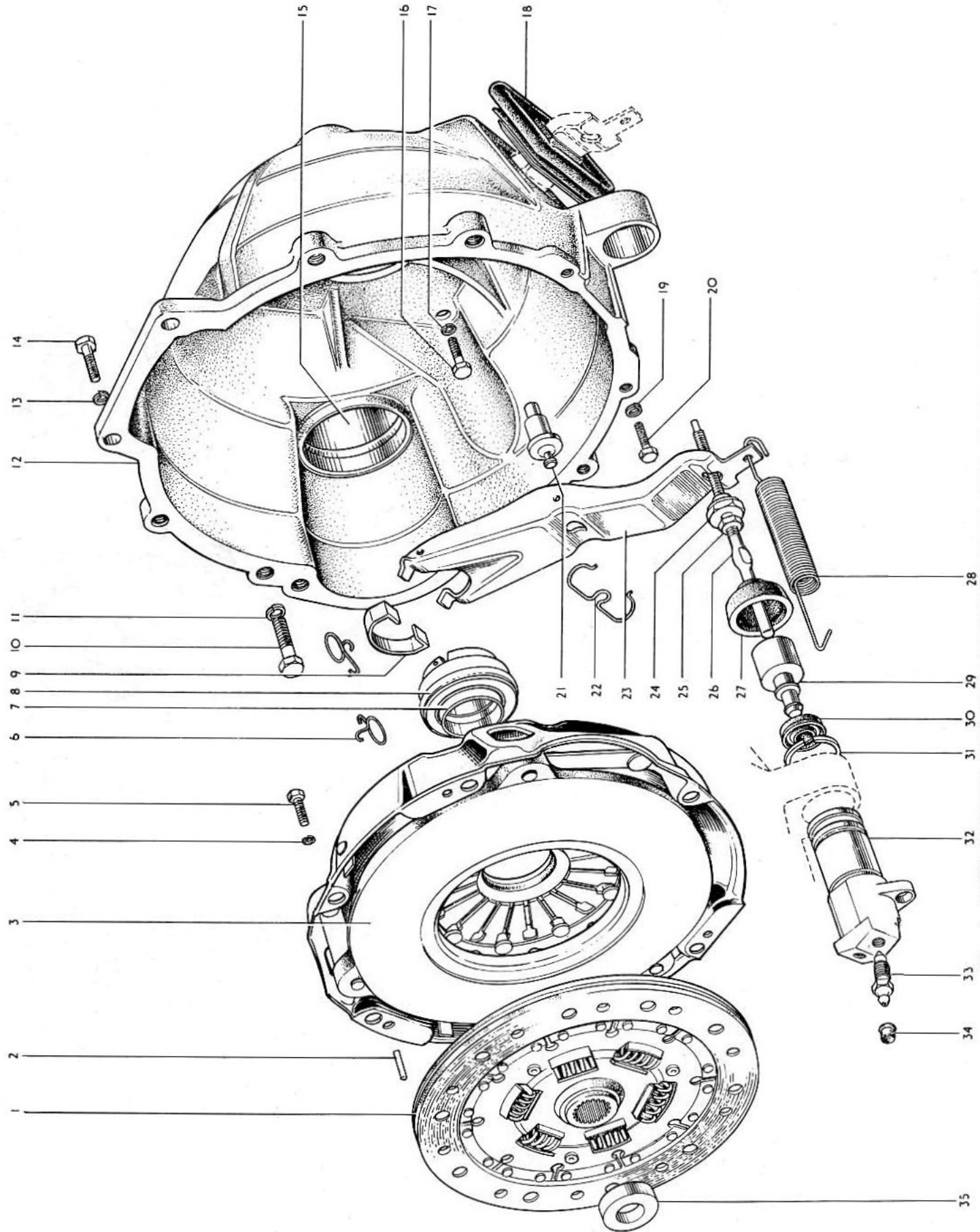

Fig. 1—THE CLUTCH, OPERATING MECHANISM AND SLAVE CYLINDER

KEY TO CLUTCH, OPERATING MECHANISM AND SLAVE CYLINDER COMPONENTS

Key No.	Description	Key No.	Description
1	8 in. D.S. pressure plate assembly (Borg and Beck)	19	Lockwasher
2	Dowel	20	Bolt (housing to engine rear cover plate)
3	Driven plate assembly	21	Pin (clutch release fork)
4	$\frac{1}{16}$ in. spring washer (clutch to flywheel)	22	Spring (clutch release)
5	$\frac{1}{8}$ in. bolt x $\frac{5}{8}$ in. long (clutch to flywheel)	23	Fork (clutch release)
6	Spring (clutch release)	24	Special nut
7	Hub (clutch release bearing) special	25	Nut
8	Clutch release bearing	26	Push rod—slave cylinder
9	Link (clutch release fork to bearing)	27	Cover (slave cylinder dust)
10	Bolt (housing to cylinder block)	28	Spring
11	Lockwasher	29	Piston (slave cylinder)
12	Housing (clutch)	30	Seal (slave cylinder)
13	Lockwasher	31	Ring (slave cylinder to clutch housing sump)
14	Bolt (housing to cylinder block)	32	Cylinder (clutch release slave)
15	Cover (starter motor drive)	33	Screw (slave cylinder bleed)
16	Bolt (housing to gearbox)	34	Cap (slave cylinder bleed screw)
17	Lockwasher	35	Bearing (clutch pilot)
18	Gaiter (clutch release fork)		

1—GENERAL DESCRIPTION

The Lotus Elan is fitted with a Borg and Beck diaphragm spring clutch of 8 in. diameter using a single dry plate with a friction area of 48.6 sq. in. Adjustment for wear is provided within the clutch itself.

In the design a single diaphragm spring provides the clamping pressure, and replaces the numerous coil springs normally used for this purpose; the diaphragm spring also serves as the clutch release mechanism. As a further refinement three pairs of spring steel straps are used to transmit the drive from the cover to the pressure plate in preference to the more commonly used method in which lugs on the pressure plate pass through slots in the cover.

Clutch release actuation is by normal Hydraulic operation, a $\frac{5}{8}$ in. master cylinder and a $\frac{7}{8}$ in. slave cylinder being used in the circuit.

The use of a diaphragm clutch offers certain advantages over the coil spring counterparts. Accurate balance of the unit is maintained at all times and renders the clutch suitable for high speeds. Reduction in friction of the release mechanism gives a reduction in operating effect.

2—REMOVING THE CLUTCH

Remove the power unit as detailed in Section E. Remove the clutch housing bolts and withdraw the gearbox from the engine, taking care to support the

gearbox until the first motion shaft is clear of the driven plate assembly.

Loosen each of the six hexagon headed securing bolts around the periphery of the clutch disc and pressure plate assembly until the diaphragm pressure is released. The clutch assembly can now be disengaged from the flywheel dowels and the whole assembly lifted off the flywheel.

3—DRIVEN PLATES

Inspection for Wear

Check the condition of the pressure plate surface and should it show any signs of distortion, scoring or overheating it is recommended that it be replaced by a new assembly. It is essential to install a complete driven plate assembly when renewal of pressure plate be required. If the facings have worn to such an extent as to warrant renewal, then slight wear will have taken place on the splines and also on the torque reaction springs and their seatings. The question of balance and concentricity is also involved. Under no circumstances is it satisfactory to repair or rectify faults in clutch driven plate centres, and we do not countenance this as manufacturers.

4—CONDITIONS OF CLUTCH FACINGS IN SERVICE

It is natural to assume that a rough surface will give a higher frictional value against slipping than a polished

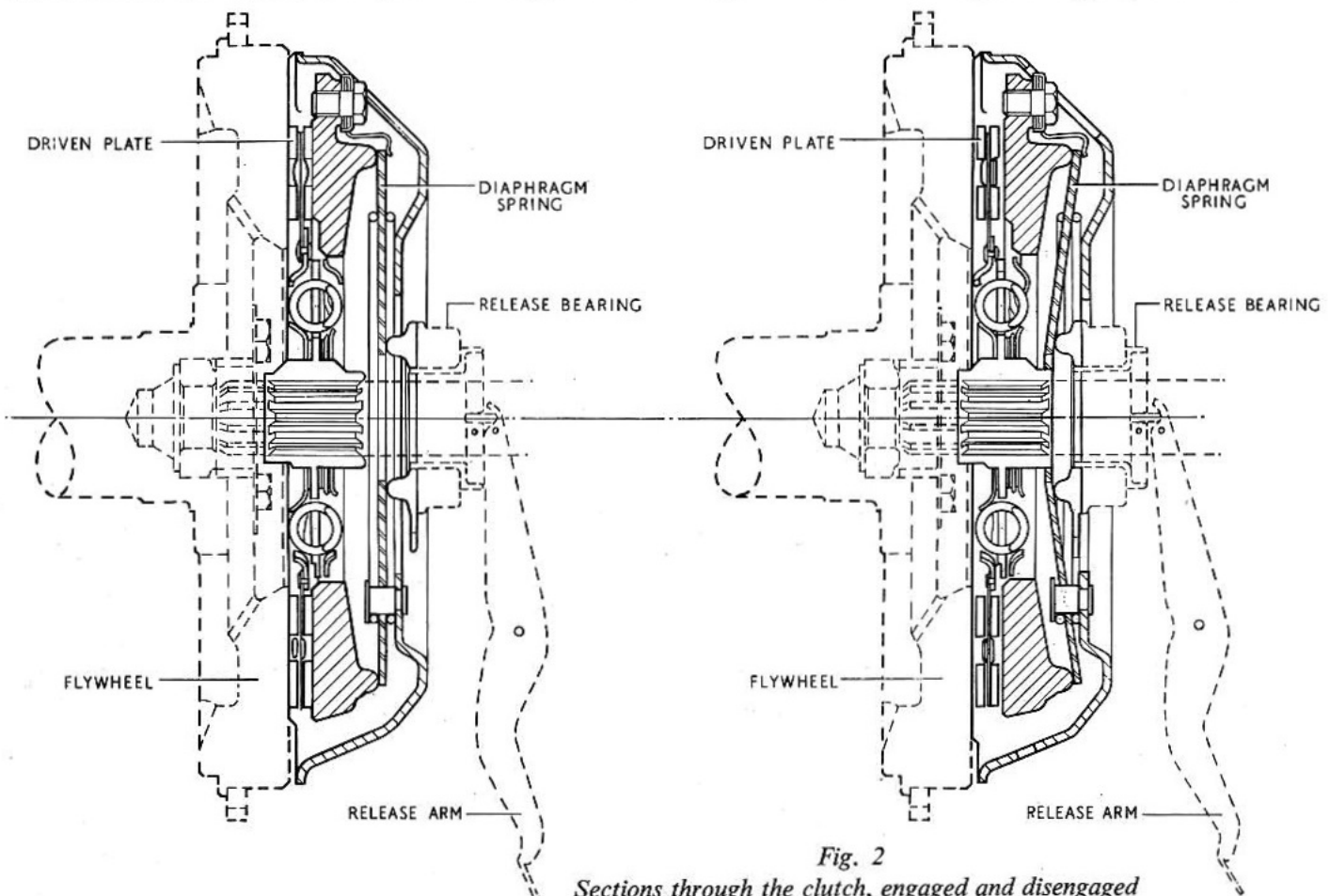

Fig. 2

Sections through the clutch, engaged and disengaged

one, but this is not necessarily correct. A roughened surface consists of small hills and dales, only the high spots of which make contact. As the amount of useful friction for the purpose of taking up the drive is dependent upon the area in actual contact, it is obvious that a perfectly smooth face is required to transmit the maximum amount of power for a given surface area.

Since non-metallic facing of the moulded asbestos type have been introduced in service the polished surface is common but it must not be confused with the glazed surface which is sometimes encountered due to conditions to be detailed subsequently. The ideally smooth or polished condition will therefore provide proper surface contact, but a glazed surface entirely alters the frictional value of the facing, and will result in excessive clutch slip. These two conditions might be simply illustrated by a comparison between a piece of smoothly finished wood and one with a varnished surface; on the former the contact is made directly by the original material, whereas in the latter instance a film of dry varnish is interposed between the contact surfaces and actual contact is made by the varnish.

If the clutch has been in use for some time under satisfactory conditions the surface of the facing assumes a high polish through which the grain of the material can be seen clearly. The polished facing is of light colour when in perfect condition.

Should oil in small quantities gain access to the clutch and find its way on to the facings, it will be burnt off as a result of heat generated by the slipping occurring under normal starting conditions. The burning of this small quantity of lubricant has the effect of gradually darkening the facings, but provided the polish of the facing remain such that the grain of the material can be distinguished clearly, it has little effect on the clutch performance.

Should increased quantities of oil obtain access to the facing, then one or two conditions, or a combination of these, may arise, depending upon the nature of the oil.

1. The oil may burn off and leave a carbon deposit on the surface of the facings, which assume a high glaze, producing further slip. This is a very definite, though very thin, deposit, and in general it hides the grain of the material.

2. The oil may partially burn and leave a resinous deposit on the facings. This has a tendency to produce a fierce clutch, and may also cause excessive spinning, due to the tendency of the face of the linings to adhere to the surface of the flywheel or pressure plate.

3. There may be a combination of conditions (i) and (ii) which produces a tendency to 'judder' on such engagement.

Still greater quantities of oil produce a dark and soaked appearance of the facings, and the result will be further slip, accompanied by fierceness or 'juddering'.

If the conditions enumerated above are experienced the clutch driven plate should be replaced by a new one. The cause of the presence of oil must be traced and re-

moved. It is of course, necessary for the clutch and flywheel to be cleaned out thoroughly before assembly.

5—CLUTCH PILOT BEARING

Removal

The clutch pilot bearing consists of a sintered bronze bush of the self-lubricating type situated in the end of the crankshaft flange. The bearing is fitted with the flat face towards the crankshaft and the shouldered face towards the clutch. To remove the bearing it is necessary to remove the clutch unit as per Chapter 2 of this section and the flywheel (Engine Section E). Using a suitable puller engaging with the centre boss of the flywheel extract the pilot bush.

(b) Replacement

Fit a replacement pilot bearing, over the hole in the end of the crankshaft with its flat face towards the crank. Using a suitable shouldered tool gently tap into position ensuring that it fits squarely into the bore. Replace the flywheel and clutch unit. (Chapter 8).

6—CLUTCH RELEASE BEARING

(a) Removal

Disconnect the retraction spring (28) on the slave cylinder, remove the rubber gaiter (18) from the arm and bell housing, noting carefully the way it was assembled. Remove the two clutch release bearing locating springs from the clutch fork (items No. 6). Draw the clutch bearing off the main drive gear bearing retainer (located on the front of the gearbox). Remove the release fork bearing link (9) and the release arm by withdrawing it into the bell housing.

(b) Dismantling the Bearing

Hold the release bearing and hub, with the bearing facing downwards. Tap the shoulder of the hub sharply on the block of wood and the bearing will separate from its hub.

(c) Re-assembling the Bearing

Fit the bearing on to the hub, with the thrust face of the bearing away from the hub shoulder. Press the hub squarely into the bearing bore.

Replacement

Slide release bearing and hub on to the main drive gear bearing retainer after lightly smearing the sleeve with high melting point grease.

Insert clutch release arm through aperture in bell housing and locate it in the correct position relative to the release bearing. Fit the release bearing link (9) ensuring that it is located correctly between grooves provided in the bearing and ends of clutch release arm.

Refit the release bearing locating springs to the bearing and release arm. Note that the ends of the springs turned into almost complete coils must be fitted to the bearing whilst the other ends (turned at right angles) must be attached to the release arm.

Position the release arm over the pivot pin (21) and secure with the retainer spring (22). It is suggested that the central loop be slid under the pivot pin head and spring ends and then be inserted in the two holes provided in the release arm.

Refit the rubber gaiter taking care to ensure that it is located correctly in the bell housing.

7—OVERHAULING THE CLUTCH PRESSURE PLATE ASSEMBLY

Owing to the design of the unit, service is reduced to a minimum, in the event of damage or weakening diaphragm pressures it is advisable to fit a service replacement unit. Wear or damage through misuse can result on the driven plate of the unit (Chapter 3) and this can be removed, and a service plate replaced as follows:

8—REPLACING THE CLUTCH

Locate the clutch disc on the flywheel, ensuring that the disc hub faces away from the flywheel. Align the clutch disc with the pilot bearing using a Ford clutch aligning tool (No. P7091).

Replace the pressure plate assembly on its locating pins and refit the six retaining bolts and spring washer. Tighten the bolts evenly to a torque of 12 to 15 lb. ft. (1.658 to 2.073 kgm.).

Replace gearbox guiding the first motion shaft carefully into position ensure that the clutch housing is correctly aligned on the tubular dowels. Fit and tighten the clutch housing bolts and the three screws securing the rear engine plate to the housing.

9—MASTER CYLINDER

Description

The inner assembly of the master cylinder is made up of the push rod circlip, dished washer plunger, and seal, spring thimble, plunger return spring valve spacer, spring washer, valve stem, and valve seal. The open end of the cylinder is protected by a rubber dust seal.

Removal

Extract the split pin and withdraw the clevis pin from the push rod yoke. Disconnect the pressure pipe union from the two screws and spring washers from the master cylinder mounting flange, the master cylinder may now be withdrawn from the vehicle.

Dismantling

Remove the retaining circlip with a pair of long-nosed pliers and extract the dished washer and push rod.

When the push rod has been removed the plunger with seals attached will be exposed; remove the plunger assembly complete. The assembly can be separated by lifting the thimble leaf over the shouldered end of the plunger. Depress the plunger return spring allowing the valve stem to slide through the elongated hole in the thimble, thus releasing the tension on the spring. Remove the thimble, spring and valve complete. Detach the valve spacer, taking care of the spacer spring washer which is located under the valve head, and remove the seal from the valve head.

Examine all parts, especially the seals, for wear or distortion and fit new parts where necessary.

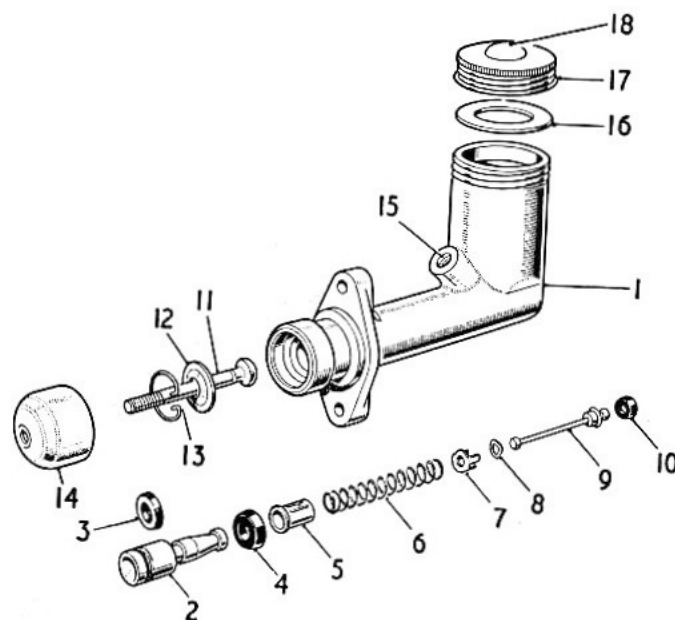

Fig. 3

The Clutch Master Cylinder Components

- | | |
|-------------------------|----------------------|
| 1. Master Cylinder body | 10. Valve seal |
| 2. Plunger | 11. Push-rod |
| 3. End seal | 12. Retaining washer |
| 4. Plunger seal | 13. Circlip |
| 5. Spring thimble | 14. Dust cover |
| 6. Spring | 15. Outlet |
| 7. Valve spacer | 16. Cap washer |
| 8. Spring washer | 17. Filler cap |
| 9. Valve stem | 18. Air vent |

Assembly

Replace the valve seal so that the flat side is correctly seated on the valve head. The spring washer should then be located with the domed side against the under side of the valve head, and held in position by the valve spacer, the legs of which face towards the valve seal. Replace the plunger return spring and depress until the valve stem engages through the elongated hole of the thimble, ensuring that the stem is correctly located

in the centre of the thimble. Check that the spring is still central on the spacer. Fit a new plunger seal with the flat face of the seal against the face of the plunger. Refit the plunger end seal using a new seal if necessary.

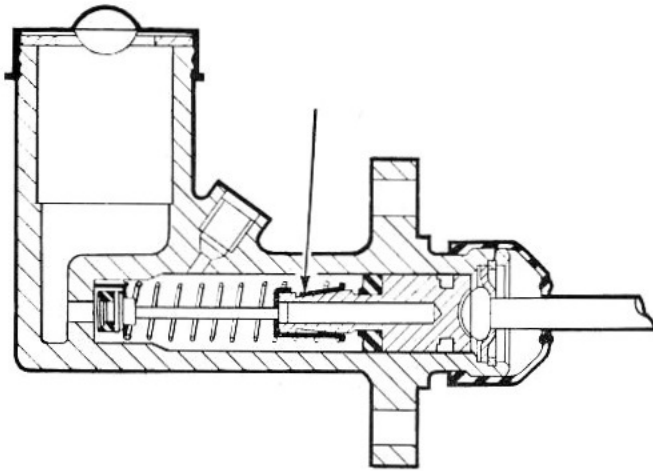

Fig. 4

The Master Cylinder. The arrow indicates the thimble leaf

Insert the reduced end of the plunger into the thimble until the thimble leaf engages under the shoulder of the plunger. Press home the thimble leaf. Smear the plunger assembly into the cylinder bore valve end first, carefully easing the plunger seal lips into the washer under the spherical head, into the cylinder followed by the circlip, which engages in the groove machined in the cylinder body.

Replacement

Locate the master cylinder on the mounting bracket on the bulkhead and fit the bolts, washers, and self-locking nuts. Replace the rubber dust cover. Line up the push rod fork with the hole in the clutch pedal lever, insert the clevis pin, and secure it with a new split pin. Finally bleed the system as detailed in Chapter 11.

10—SLAVE CYLINDER DESCRIPTION

The slave cylinder is of a simple construction, consisting of an alloy body piston with seal operated by an adjustable push rod, and a bleed screw situated in the end of the cylinder. The open (push rod) end is protected by a rubber dust cover. A circlip secures the slave cylinder to a lug on the left-hand side of the clutch bell housing. A retraction spring is connected from the clutch release fork to a lug on the slave cylinder and serves to retain the clutch operating mechanism in the released position.

Remove and Dismantle

Disconnect the retraction spring, remove the retaining circlip of the cylinder by using a pair of circlip pliers. Withdraw the unit from the lug on the bell housing at

the same time removing the dust cover and push rod. Depress the clutch pedal to push the piston and seal out of the cylinder. Disconnect the flexible hose, bleed valve and ball from the cylinder. Gently pull the piston seal from its spigot at the front end of the piston.

Wash all parts in alcohol methylated spirits or hydraulic fluid, do not use petrol or paraffin and examine carefully especially the seal, renew if worn or damaged.

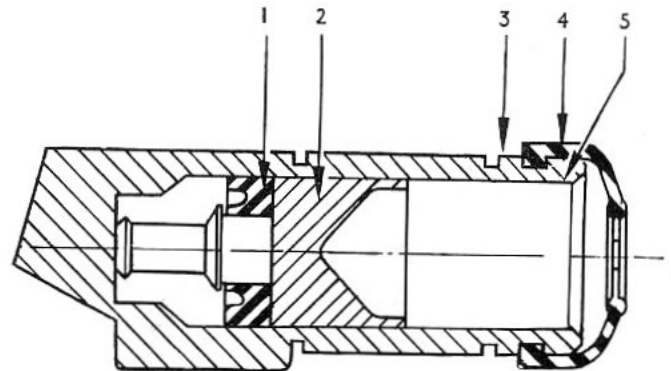

Fig. 5

The Clutch Slave Cylinder Components

- | | | |
|-----------|---------------|---------|
| 1. Seal | 3. Circlip | 5. Body |
| 2. Piston | 4. Dust Cover | |

To Assemble or Replace

Place the seal on the spigot with the back of the seal against the piston (see Fig. 1). Smear with hydraulic fluid and carefully insert the spigot end first into the cylinder. Replace the bleed valve (do not tighten). Reconnect the flexible hose to the cylinder. Insert the cylinder into its location in the lug on the side of the bell housing and refit the circlip ensuring that it is located correctly within its groove. Replace the push rod assembly and dust cap and reconnect the retraction spring. Bleed the clutch circuit of the hydraulic system and adjust the clearance between push rod and clutch release arm.

11—BLEEDING THE CLUTCH SYSTEM

Open the bleed screw on the slave cylinder three quarters of a turn and attach a tube immersing the open end in a clean receptacle containing a small quantity of the recommended hydraulic fluid. Fill the master cylinder reservoir with fluid. The use of Girling Hydraulic Brake Fluid is recommended but if this is not available an alternative fluid conforming to Specification S.A.E. 70 R1 should be used. Using slow, full strokes, pump the clutch pedal until the fluid entering the container is completely free from air bubbles. On a downstroke of the pedal tighten the bleed screw and remove the bleed tube.

SECTION G**GEARBOX**

	<i>Chapter</i>
General description	1
Removing the gearbox	2
Dismantling the gearbox	3
Reassembly of the gearbox	4
Gearbox external and remote control components	<i>Illustration</i>
Gearbox external and remote control components	<i>Key to components</i>
Gearbox internal components	<i>Illustration</i>
Gearbox internal components	<i>Key to components</i>
Gearbox build specification	5

1—GENERAL DESCRIPTION

The gearbox fitted to the Lotus Elan is equipped with four forward speeds which are all of the constant mesh type and fitted with synchromesh engagement. One reverse gear of the normal spur type is also fitted in the box whilst all the forward constant mesh gears are of the helical type, to ensure quiet operation. The gears are selected manually by a floor mounted gear lever, the operation of which is explained in section B (Introduction to the Vehicle).

The gear lever operates three selector shafts, operating each individually at one time. These three selector shafts run parallel to the main shaft and counter shafts in the top of the gearbox, and each is fitted with a selector fork. The selector forks on these shafts with grooves machined in each gear synchroniser sleeve. The left-hand shaft and fork, operates third and top gear synchroniser sleeve engagement, whilst the centre shaft fork operates first and second speed synchroniser sleeves. The fork on the third and right-hand shaft engages with the reverse gear idler hub.

A bearing locates the main drive gear shaft in the rear of the crankshaft which is meshed with the counter shaft gear cluster. The gearbox main shaft is carried at its forward end within the main drive gear shaft and is further supported in a carrier situated between the gearbox and extension housing. The rear of the main shaft is carried by a sliding joint within the tail of the extension housing.

First, second and third gears are in constant mesh with the counter shaft gear cluster and freely rotate on the main shaft. Forward gears are engaged by blocker ring synchroniser assemblies splined to the main shaft and situated between first and second gears and third and top gears. The reverse spur gear is integral with the first and second gear synchroniser sleeve and meshes with an idler spur gear on a shaft running parallel to the main shaft.

The synchroniser assemblies comprise a hub, splined to the main shaft and running, within a splined sleeve. This hub incorporates three blocker bars held by a spring against the synchroniser sleeves. These blocker bars engage with notches machined in the internal splines of the sleeve and notches of a "blocker ring" which is situated between each synchroniser and forward gear. When engaging a forward gear the synchroniser is moved towards the selected gear, and the bars also move, pushing the blocker ring into contact with the tapered face of the gear. The gear would be revolving at a different speed to the main shaft and synchroniser and the frictional resistance created will keep one side of the blocker bars against their slots preventing any engagement. When the revolutions match the blocker ring will centralise and the bars will then permit the sleeve to slide fully home engaging the dog teeth of the forward gear.

Lubrication is effected by extreme pressure gear oil picked up from the base of the gearbox casing by the countershaft gear cluster as it revolves and thence to the main shaft and main drive gears and bearings, etc.

Lubricant is returned from the main drive gear bearing to the gearbox case by a slot in the bearing retainer and a drain hole in the front of the case. Oil is carried to the extension housing in a channel where main shaft extension bearing and speedometer gears are lubricated.

2—REMOVING THE GEARBOX

Accessibility for the removal of the gearbox and clutch housing from the engine unit whilst still in the vehicle is extremely limited. The clutch housing is bolted to the front of the gearbox internally and this in turn is bolted to the rear of the engine back plate. If any major overhaul or work is contemplated that necessitates the removal of these components, then it is recommended that the complete engine and gearbox unit be removed.

To remove the engine and gearbox unit it is necessary to adhere to the instructions laid down in section E, chapter 4 (a).

Removal of the clutch operating mechanism from within the bell housing should be facilitated by a study of section G and the appropriate illustrations.

With the engine and gearbox unit mounted on a service stand or bench, remove the bolts and spring washers securing the clutch bell housing to the cylinder block. Remove the three set screws from the lower section of the bell housing that secure it to the rear of the engine back plate. Supporting the gearbox carefully remove it from the engine. Dismantle the clutch release mechanism by detaching the gaiter, retaining and locating springs on the release arm and withdraw the separate components. Slide the clutch release bearing and hub off the main drive gear bearing retainer. Remove the four bolts and lockwashers that secure the bell housing to the front face of the gearbox and remove housing.

3—DISMANTLING THE GEARBOX

Detach both the gear change cover and gearbox case cover by unscrewing the eight bolts and lockwashers. Care must be taken when lifting off the gearbox case cover that the gear change ball springs are not lost. The three springs, along with the balls, should then be removed.

With the gears in neutral, unscrew the gear change fork retaining screws, first removing the locking wire from each screw head. Having withdrawn the reverse gear change shaft, remove the third and top gear change shaft, taking care to retain the sleeve fitted to this shaft. Withdraw the last remaining gear change shaft and remove the gear change shaft interlocking pin. It is necessary to turn the shaft slightly to fully withdraw it. Finally lift out the gear change forks and remove the gear change shaft interlocking plungers.

To remove the extension housing and main shaft, the extension housing must first be freed by undoing the five bolts and lockwashers and, with a gap of $\frac{1}{4}$ in. between the two faces, rotated on its axis through an arc of 90° in an anti-clockwise direction, so enabling the countershaft to be removed, first by drifting and then by the use of a dummy countershaft. The extension housing having been withdrawn to its limit, the reverse gear shaft may be removed, with the aid of a suitable extractor tool. The extension housing and main shaft assembly may now be freely withdrawn, and the reverse gear assembly removed. Care must be exercised when removing the last items that the needle rollers in the main drive gear are not displaced.

Having unscrewed the three retaining bolts remove the main shaft bearing carrier and, by contracting the circlip inside the carrier, withdraw the gear and bearing. Next, push out the dummy countershaft and remove the gearbox countershaft cluster complete with two sets of twenty rollers, retaining washers and tubular spacer.

Remove the speedometer right angle drive unit and then compress the main shaft retaining circlip. It is now possible to withdraw the main shaft and undo the nut retaining the tap washer, speedometer driving gear, locating ball and sleeve. The next operation is to remove the main shaft bearing, first and second gear assembly, second gear blocker ring and second gear from the main shaft by the use of an adapter. Detach the third and top speed synchroniser sleeve and remove the third and top speed synchroniser hub inserts and gearbox synchroniser spring. Having removed the circlip, slide off the third and top speed synchroniser hubs, synchroniser ring and third gear, using a suitable adapter.

By removing the circlip and supporting the bearing in an adapter it will be possible to push out the main drive gear complete with oil slinger.

To overhaul the extension housing remove the oil seal from the extreme end of the housing and examine the bearing bush for wear. Replace if necessary. Care should be taken when replacing the oil seal to ensure that the lip faces inwards.

4—REASSEMBLY OF THE GEARBOX

In the following sequences care should be taken to ensure that all mating marks correspond.

If the installation of a new unit is contemplated it is first necessary to press the synchroniser sleeve off the hub and locate the inserts within the hub ensuring that their flat extensions are within the retaining plate and the tag on the end of the spring is inside one insert. The other end of the spring should be left free. Having made a note of which insert contains the spring tag, and the direction of rotation of the spring, slide on the first and second speed synchroniser sleeve keeping the gear change fork groove to the rear. Add the front insert spring, the tags of both springs locating in the same insert but running in the opposite directions.

Next with the gear teeth facing the thrust collar, slide the second speed gear onto the main shaft. Position the synchroniser ring on the taper face of the second speed gear and then slide the first and second speed synchroniser onto the main shaft. Having located the main shaft bearing circlip over the main shaft, place the bearing on the shaft in such a way that the radiused edge faces rearwards. Complete the assembly with the aid of adapters, support ring and a press. The third speed gear and synchroniser ring may next be slid onto the shaft in the same attitude as the second gear. Place one of the insert springs in the rear of the third and top speed synchroniser hub and then place this on the main shaft with the long boss facing forwards. Press the complete assembly onto the shaft using a suitable adapter as support. Retain the synchroniser with a circlip. Fit the insert and the remaining spring, noting that the same procedure should be followed as was recommended for the first and second speed synchroniser. To complete the assembly of the main shaft add the spacer, speedometer driving gear locating ball, speedometer driving gear, tab washer and nut. The speedometer driving gear should be assembled with its shoulder to the rear. Lock the nut after tightening to 20—25 lb./ft. (2.76—3.45 kg./in.) torque by bending up a segment of the tab washer.

Now pass the main shaft assembly through the main shaft bearing which should be keyed in position in the extension housing by a circlip, the legs of which are held in a cut-out in the bearing carrier. Replace the speedometer driven gear and right-angle drive unit.

The dummy countershaft utilized in the removal of the countershaft and gear cluster is used now as a basis on which to reassemble the unit. Build up the tubular spacer with a washer at each end in the cluster gear on the dummy countershaft. Make up the roller bearings by placing twenty rollers at each end of the gear cluster, held in place with thick grease. Having positioned the thrust washers in the appropriate recesses place the dummy countershaft and gear cluster assembly in the gearbox. Also place in the gearbox the reverse gear assembly.

Next the main drive gear should be completed by the addition of the oil slinger and main bearing. The oil slinger should have its concave face towards the gear and similarly the bearing should have its broad shoulder to the rear. Press the bearing over the shaft and retain it with a circlip. Before offering the assembled gear to the front face of the gearbox and retaining it with a circlip, insert the thirteen needle rollers holding them in thick grease. Making sure that the new gearbox front face gasket does not block or partially block the oil passage, carefully align the bearing retainer with the gearbox front face and secure with three bolts and lockwashers. Next, using another new gasket fit the extension housing by passing the main shaft assembly through the rear of the gearbox until the main shaft and main drive gear mate, the nose of the main shaft running in the roller-race. Ensuring that the flats will line up in the recess in the extension housing install the reverse idler shaft. To complete the assembly of the countershaft gear a reversal

FILE NOT TO BE REDISTRIBUTED FOR PROFIT ORIGINAL COPYRIGHT HOLDER LOTUS CARS LIMITED 1966

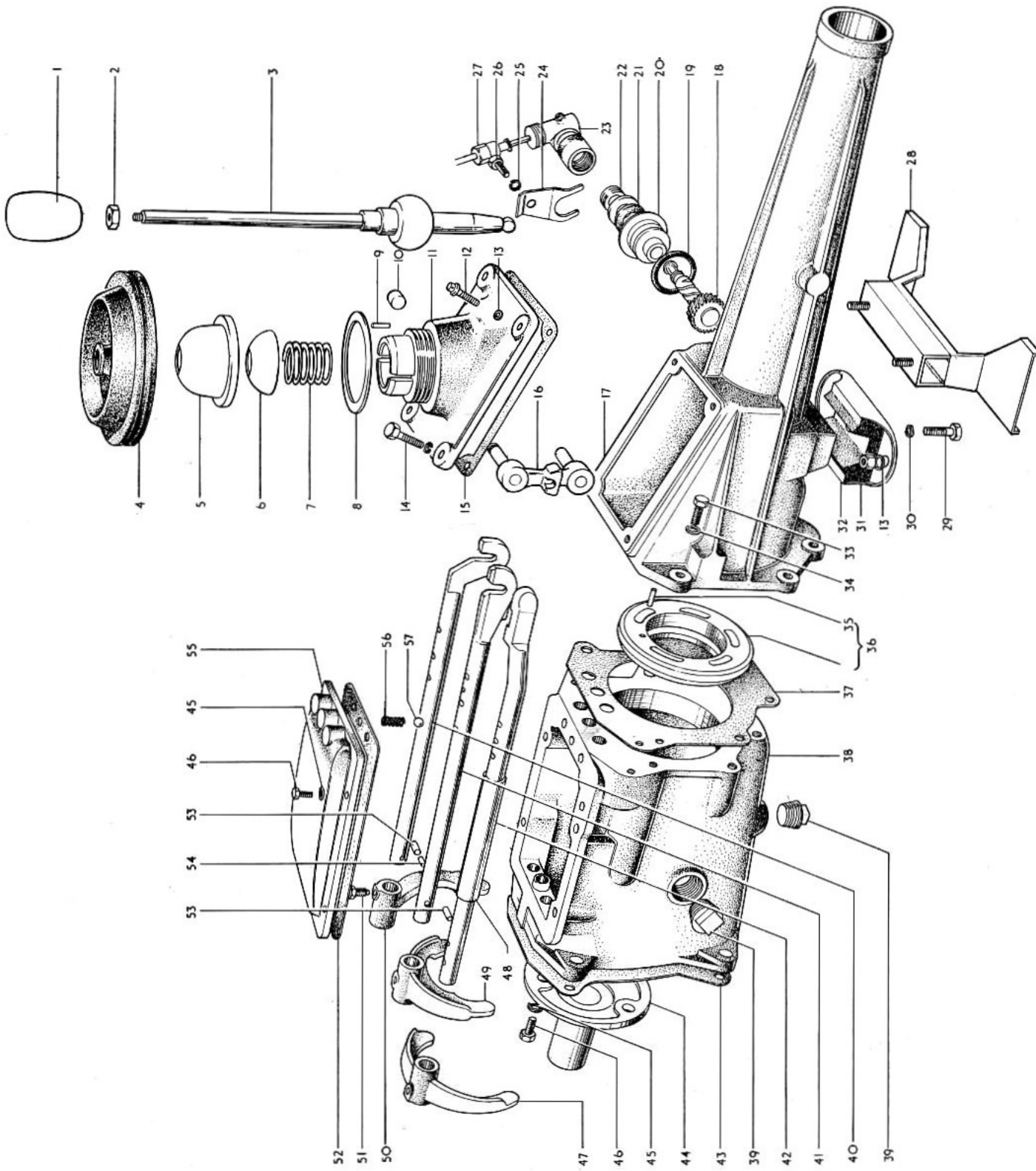

Fig. 1—GEARBOX EXTERNAL AND REMOTE CONTROL COMPONENTS

KEY TO GEARBOX EXTERNAL AND REMOTE CONTROL COMPONENTS

Key No.	Description	Key No.	Description
1	Knob (gear change lever)	30	Washer (spring)
2	Locknut (gear change lever knob)	31	Nut
3	Lever	32	Insulator (engine rear support assembly)
4	Gear lever grommet	33	Bolt (engine rear support assembly)
5	Cap (gear change lever retaining)	34	Washer (spring rear support assembly)
6	Seat (gear change lever spring)	35	Pin (bearing housing spring)
7	Spring (gear change lever)	36	Housing (gearbox main shaft assembly)
8	Gasket (gear change lever retaining cap)	37	Gasket (extension housing to gearbox)
9	Pin (gear change lever to housing)	38	Case (gearbox)
10	Plug (gear change cover)	39	Plug (gearbox oil filler and drain)
11	Cover (gear change)	40	Shaft (reverse gear change)
12	Vent (gear box extension housing)	41	Shaft (1st and 2nd gear change)
13	Lockwasher	42	Shaft (3rd and 4th gear change)
14	Bolt (gear change cover to extension housing)	43	Gasket (clutch housing to gearbox)
15	Gasket (gear change housing to extension housing)	44	Retainer (gearbox main drive gear)
16	Lever (reverse gear change) assembly	45	Lockwasher
17	Extension housing	46	Bolt (retainer to gearbox case)
18	Gear (speedo driven) assembly—25 teeth	47	Fork (3rd and 4th speed gear change)
19	Seal (bearing to gearbox extension housing)	48	Sleeve (3rd and 4th speed gear change shaft)
20	Bearing (speedo driven gear)	49	Fork (1st and 2nd speed gear change)
21	Gasket (speedo casing to gearbox)	50	Fork (reverse gear change)
22	Adapter (right angle drive to gear box)	51	Screw (gear change fork securing)
23	Right angle drive	52	Gasket (gearbox case cover)
24	Clip (case to gearbox)	53	Plunger (gear change shaft interlock)
25	Washer (spring)	54	Pin (gear change shaft interlock)
26	Bolt (clip to gearbox)	55	Cover (gearbox case)
27	Speedometer drive cable	56	Spring (gear change ball)
28	Gearbox mounting	57	Ball (gear change spring)
29	Bolt		

FILE NOT TO BE REDISTRIBUTED FOR PROFIT ORIGINAL COPYRIGHT HOLDER LOTUS CARS LIMITED 1966

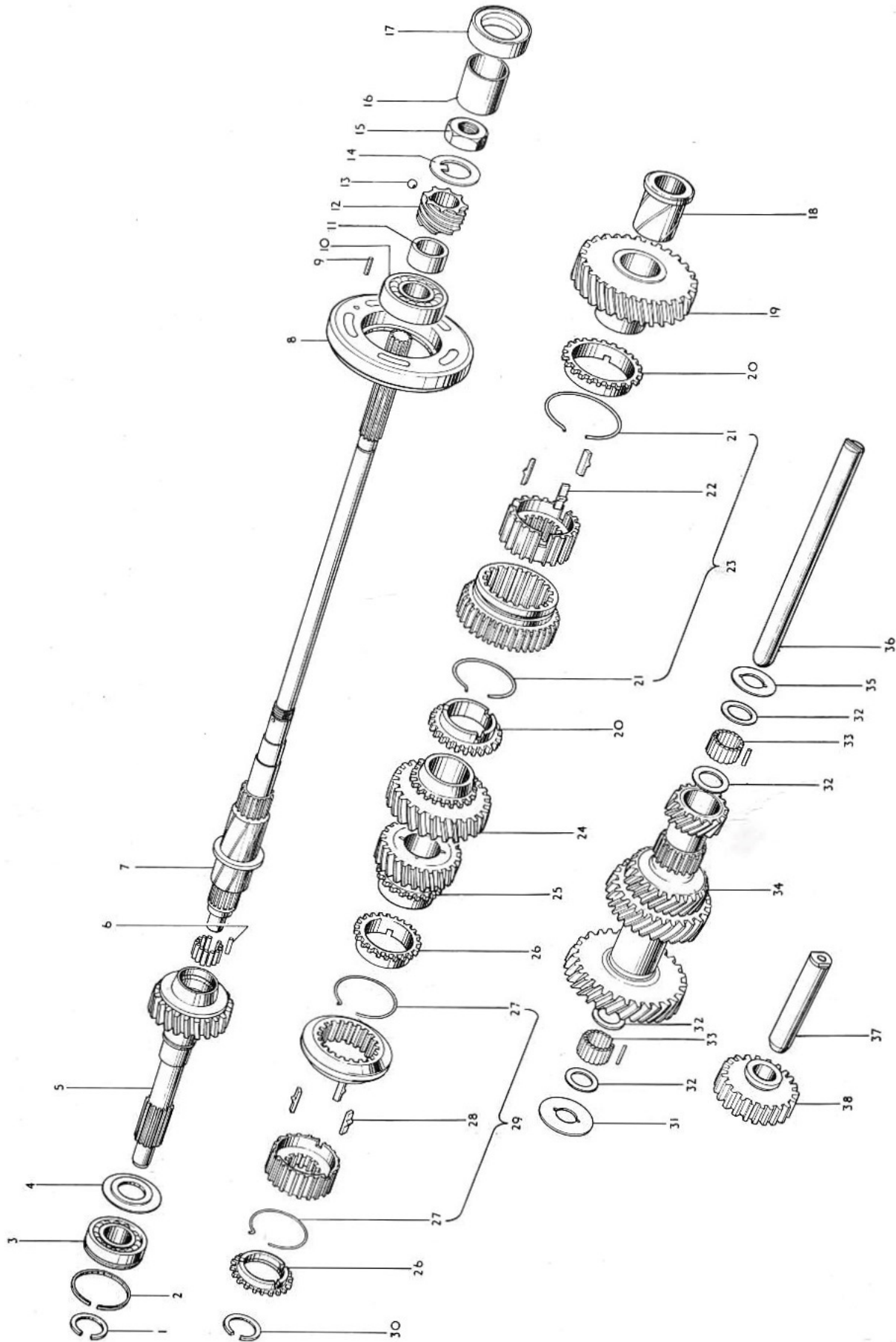

Fig. 2—GEARBOX INTERNAL COMPONENTS

KEY TO GEARBOX INTERNAL COMPONENTS

Key No.	Description	Key No.	Description
1	Ring (main drive gear snap .0870 in.—0899 green)	20	Ring (gear synchroniser blocking)
2	Ring (main drive gear bearing snap)	21	Spring (gearbox synchroniser)
3	Bearing (main drive gear)	22	Insert (gearbox 1st and 2nd speed synchroniser hub)
4	Baffle (main drive gear oil)	23	Synchroniser (gearbox 1st and 2nd speed) assembly
5	Gear (gearbox main drive) (close ratio)	24	Gear (gearbox 2nd speed) (close ratio)
6	Roller (gearbox main shaft pilot bearing)	25	Gear (gearbox 3rd speed) (close ratio)
7	Main shaft (gearbox)	26	Ring (synchroniser)
8	Bearing carrier (gearbox main shaft bearing)	27	Spring (gearbox synchroniser)
9	Pin (bearing housing spring)	28	Insert (3rd and 4th speed synchroniser hub)
10	Bearing (gearbox main shaft ball assembly)	29	Synchroniser (gearbox 3rd and 4th speed assembly)
11	Sleeve	30	Ring snap (3rd and 4th speed synchroniser hub)
12	Gear (speedometer driving)	31	Washer (gearbox countershaft thrust)
13	Ball	32	Washer (countershaft)
14	Tab washer (main shaft)	33	Roller (gearbox countershaft gear bearings)
15	Nut (main shaft)	34	Gear (gearbox countershaft) (close ratio)
16	Bearing (gearbox extension housing)	35	Washer (gearbox countershaft thrust) rear
17	Oil seal (gearbox extension housing)	36	Countershaft gearbox
18	Sleeve (gearbox main shaft)	37	Shaft (gearbox reverse gear)
19	Gear (gearbox 1st speed)	38	Gear (gearbox reverse) assembly

of the dismantling procedure must be followed, the extension first being rotated on its axis through 90° in an anti-clockwise direction. With the gear in mesh with both the main shaft and main drive gear, refit the countershaft taking particular care to keep it in constant contact with the dummy countershaft. With the countershaft in position, and with the locking faces on the countershaft and reverse idler shaft coinciding with the extension housing recesses, reposition the extension housing and press it to the gearbox. Complete the assembly, with five bolts and lockwashers, retaining the earthing strap with the lower left-hand bolt. Using four bolts and lockwashers bolt the bell housing in place, and, if the clutch release arm fulcrum pin was removed in any earlier operation replace this item. The next move is to reassemble the clutch release mechanism. Having passed the clutch release arm through the aperture in the bell housing locate the release bearing on the main drive gear bearing retainer. The clutch release arm bearing link is next added, being held only by the locating grooves in both the clutch release arm and the bearing and the pressure of the locating springs which are the next items to be affixed, the ends of the springs with the three-quarter coils being fitted to the bearings. Locate the clutch release arm on the fulcrum pin, the head of the pin protruding through the hole in the centre of the arm and being retained by the fulcrum pin retaining spring which is sprung into two, one either side of the release arm. Finally slide the gaiter over the clutch release arm and force it into the aperture in the bell housing.

If the interlocking plungers are not in place insert them using a suitable guide tool and then replace the expansion plug. Place the gearbox in neutral and install the gear change forks in their correct positions, noting that the third and top gear selector faces the opposite way to the other two, its longer boss facing rearwards. Install the first and second gear change shaft, rotating it through 90° to clear obstructions. Check that the floating pin is in position in the shaft and push the shaft right home, bolting the gear change fork to it with a square-headed bolt locked with wire. Repeat this operation for the other two shafts, taking care not to omit the sleeve on

the third and top gear change shaft. Replace the three locking-balls, and, fit a new gasket in position, bolt on the gearbox case cover with four bolts and lockwashers, taking care to position correctly the locking-ball springs. Four more bolts, one drilled to act as a breather and four lockwashers are used to bolt the gear change cover to the top of the extension housing, also complete with a new gasket. A quick check will show that the selectors can be easily manipulated and the correct gears obtained.

Mate the bell housing on the tubular dowels and bolt the gearbox to the engine. Reconnect the speedometer drive cable complete with a new paper gasket between it and the drive unit and bolt the retainer in place. Add the clutch slave cylinder and starter motor. The slave cylinder is pushed home from the front and the retaining circlip, rubber boot, push rod and spring added, while the starter motor is attached to the bell housing with two bolts and spring washers and the cable and terminal reconnected.

With the gasket between the ball cap and gear change cover, tighten the ball cap. Screw in the gearbox drain plug, refill with the correct grade of oil and finally add the filler plug.

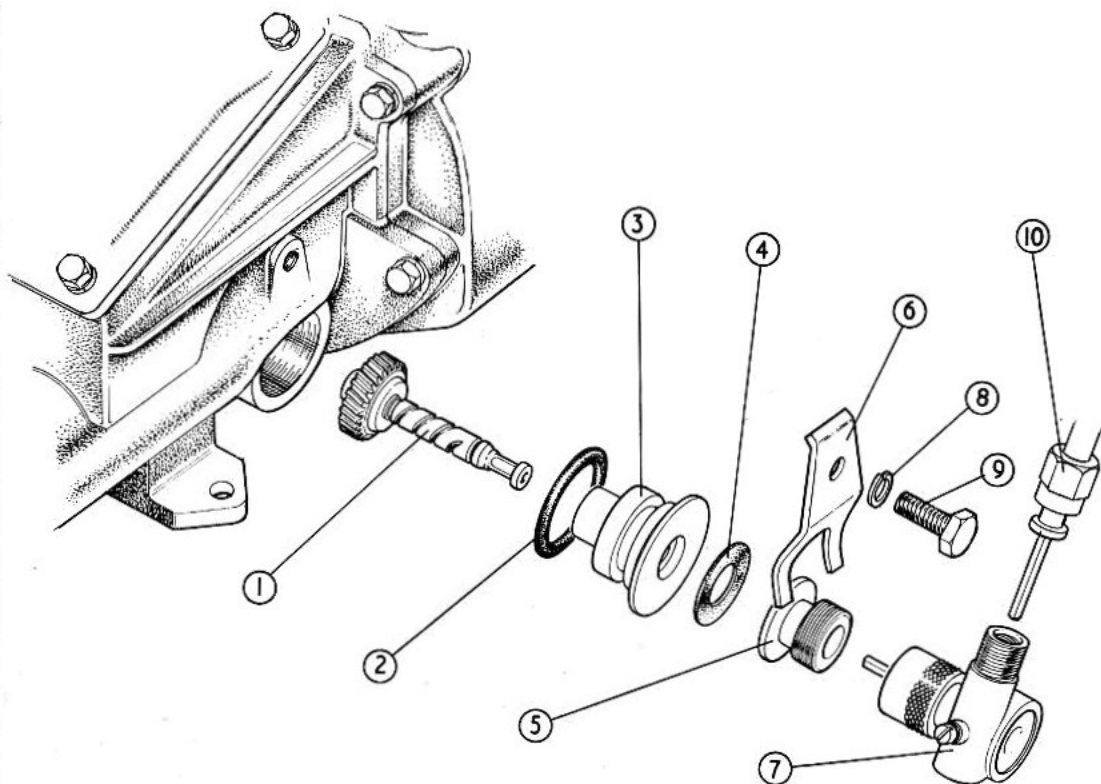

Fig. 3—Speedometer drive take-off assembly.

- | | |
|---|---------------------------|
| 1. Nylon driven gear 25T. | 6. Clip (case to gearbox) |
| 2. "O" ring (bearing to gearbox) | 7. Right angle drive unit |
| 3. Bearing (driven gear) | 8. Spring washer |
| 4. Gasket (shaft casing to gearbox) | 9. Bolt (clip) |
| 5. Adapter (right angle drive to gearbox) | 10. Speedometer cable |

5—GEARBOX BUILD SPECIFICATION

Ratios, assembly clearances and limits

Ratios:				Gearbox Ratio				Ratios:				Gearbox Ratio														
First	3.543	:	1	Fourth	1	:	1	Reverse	3.963	:	1						
Second	2.396	:	1																				
Third	1.412	:	1																				
Main Drive Gear:																										
No. of teeth	17						
I.D. gear end	0.9725 to 0.9732 in. (2.4702 to 2.4719 cm.)						
Main shaft pilot end diameter	0.5960 to 0.5965 in. (1.514 to 1.515 cm.)						
Countershaft Gear Cluster:																										
No. of teeth	<table border="0" style="display: inline-table; vertical-align: middle;"> <tr><td rowspan="5" style="font-size: 3em; vertical-align: middle;">}</td><td>32</td></tr> <tr><td>28</td></tr> <tr><td>22 (Reverse)</td></tr> <tr><td>19</td></tr> <tr><td>17</td></tr> </table>	}	32	28	22 (Reverse)	19	17
}	32																									
	28																									
	22 (Reverse)																									
	19																									
	17																									
End float	0.008 to 0.020 in. (0.203 to 0.508 mm.)						
Bore diameter (for rollers)	0.933 to 0.934 in. (2.370 to 2.372 cm.)						
Thrust washer thickness	0.061 to 0.063 in. (0.155 to 0.160 cm.)						
No. of rollers	40						
Countershaft diameter	0.6818 to 0.6823 in. (1.732 to 1.733 cm.)						
First Gear:																										
End float	0.005 to 0.010 in. (0.127 to 0.254 mm.)						
Internal diameter	1.3763 to 1.3770 in. (3.495 to 3.498 cm.)						
No. of teeth	32						
First Gear Bush:																										
Internal diameter	1.0459 to 1.0505 in. (26.568 to 26.683 mm.)						
External diameter	1.374 to 1.3745 in. (34.902 to 34.915 mm.)						
Finish	Phosphate Coat						
Second Gear:																										
End float	0.005 to 0.010 in. (0.127 to 0.254 mm.)						
Internal diameter	1.376 to 1.377 in. (3.495 to 3.498 cm.)						
No. of teeth	28						
Third Gear:																										
End float	0.005 to 0.016 in. (0.127 to 0.406 mm.)						
Internal diameter	1.376 to 1.377 in. (3.495 to 3.498 cm.)						
No. of teeth	21						
Reverse Main shaft Gear:																										
(First and Second Gear Synchroniser Sleeve)																										
No. of teeth	40						
Reverse Idler Gear:																										
Internal diameter	0.7500 to 0.7508 in. (1.905 to 1.907 cm.)						
Shaft diameter	0.7465 to 0.7470 in. (1.896 to 1.898 mm.)						
No. of teeth	22						
Speedometer Drive Gear:																										
No. of teeth	7						
Speedometer Driven Gear:																										
No. of teeth	25						
Identifying Colour	Blue						

FILE NOT TO BE REDISTRIBUTED FOR PROFIT ORIGINAL COPYRIGHT HOLDER LOTUS CARS LIMITED 1966

FILE NOT TO BE REDISTRIBUTED FOR PROFIT ORIGINAL COPYRIGHT HOLDER LOTUS CARS LIMITED 1966

SECTION H

THE PROPELLER SHAFT

	<i>Chapter</i>
Description	1
Lubricating the universal joints	2
Testing for wear	3
Removing the propeller shaft	4
Dismantling the propeller shaft	5
To examine and check the wear	6
Re-assembling the shaft	7
Replacing the propeller shaft	8

1—DESCRIPTION

The propeller shaft and universal joints are of the Hardy Spicer type with needle-roller bearings.

A single shaft connects the rear axle and the gearbox. To accommodate fore and aft movement of the axle a sliding joint of the reverse spline type is fitted between the gearbox and the front universal joint flange. Each joint consists of a centre spider, four needle-roller bearing assemblies, and two yokes.

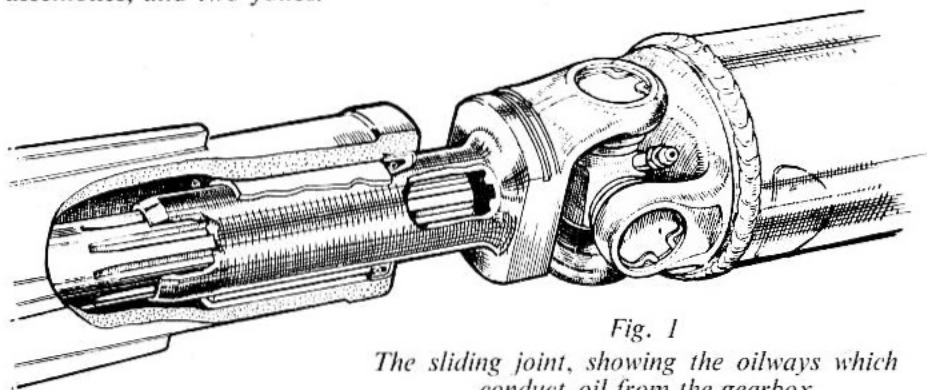

*Fig. 1
The sliding joint, showing the oilways which
conduct oil from the gearbox*

2—LUBRICATING THE UNIVERSAL JOINTS

A lubricator is fitted to each front and rear spider, and should be charged fully after overhauling and subsequently given three or four strokes with the grease gun every 1,000 miles (1,600 km.). The correct lubricant is grease to Ref. D (Section C).

If a large amount of grease exudes from the oil seal the joint should be dismantled and new oil seals fitted.

The sliding joint is automatically lubricated from the gearbox.

IMPORTANT—The nipple type universal joints fitted to the Lotus Elan propeller shaft have now been superseded by those of a greaseless type. These are pre-packed on manufacture and consequently require no further service or lubrication. In the event of wear, replacement of the complete joint is necessary.

3—TESTING FOR WEAR

Wear on the thrust faces is ascertained by testing the lift in the joint either by hand or with the aid of a length of wood suitably pivoted.

Any circumferential movement of the shaft relative to the flange yokes indicates wear in the needle-roller bearings, or in the splined shaft in the case of the forward joint.

4—REMOVAL OF THE PROPELLER SHAFT

Remove the nearside rear suspension as outlined in Section I, Chapter 1. Carefully mark the mating flanges of the propeller shaft and differential to assist in replacing them in their original positions. Undo the four $\frac{5}{16}$ in.

bolts and Nyloc nuts holding the propeller shaft to the differential pinion flange.

Withdraw propeller shaft rearwards from the splines on gearbox tail shaft. It will be found that the unit can be removed from the car by sliding it out of the tunnel diagonally across the lower wishbone and the under-surface of the boot floor.

It should be emphasised that the propeller shaft can only be extracted in this fashion from the near side, and that the suspension unit including the flexible coupling be removed to facilitate the operation.

5—DISMANTLING THE PROPELLER SHAFT

Remove the enamel and dirt from the snap rings and bearing faces. Remove all the snap rings by pinching their ears together with a pair of thin-nosed pliers and prising them out with a screwdriver.

If a ring does not slide out of its groove readily tap the end of the bearing race slightly to relieve the pressure against the ring. Remove the lubricator from the journal and, holding the joint in one hand, tap the radius of the yoke lightly with a copper hammer (Fig. 2). The bearing should begin to emerge; turn the joint over and finally remove with the fingers. If necessary, tap the bearing race from inside with a small-diameter bar (Fig. 3), taking care not to damage the bearing face, or grip the needle bearing race in a vice and tap the flange yoke clear.

Be sure to hold the bearing in a vertical position, and when free remove the race from the bottom side to avoid dropping the needle-rollers.

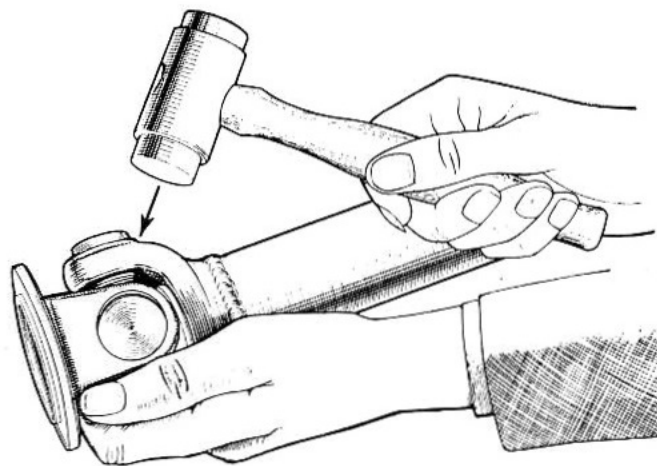

*Fig. 2
Where to apply light blows to the yoke after removing the
retaining circlip*

Repeat this operation for the opposite bearing.

Rest the two exposed trunnions on wood or lead blocks to protect their ground surfaces, and tap the top lug of the flange yoke to remove the bearing race.

Turn the yoke over and repeat the operation.

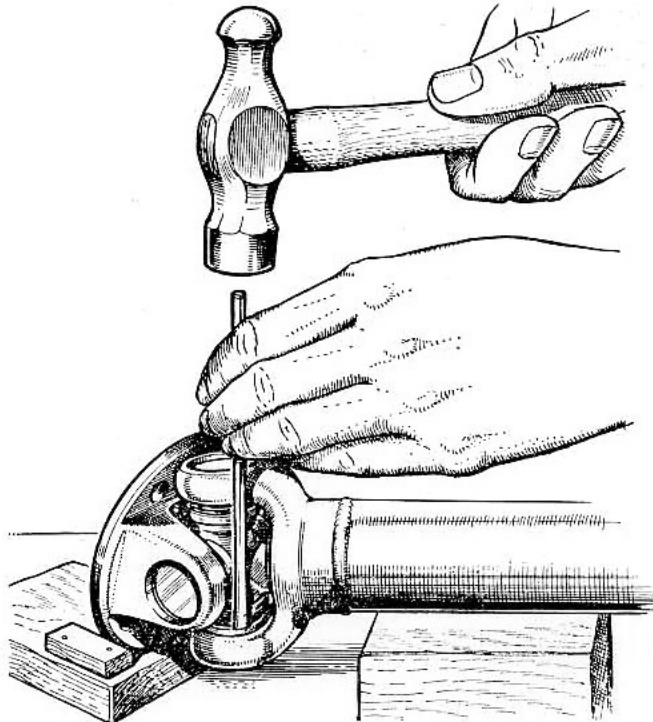

Fig. 3

When dismantling a universal joint the bearings may be tapped out with a small-diameter rod from the inside as shown. Take care not to damage the roller races

6—TO EXAMINE AND CHECK THE WEAR

The parts most likely to show signs of wear after long usage are the bearing races and the spider journals. Should looseness, load markings, or distortion be observed, the affected part must be renewed complete; no oversized journals or races are provided.

It is essential that the bearing races are a light drive fit in the yoke trunnions. In the event of wear taking place in the yoke cross-holes, rendering them oval, the yokes must be renewed. In case of wear in the cross-holes in the fixed yoke, which is part of the tubular shaft assembly, it should be replaced by a complete tubular shaft assembly.

7—RE-ASSEMBLING THE SHAFT

See that all the drilled holes in the journals are thoroughly cleaned out and free from grease.

Assemble the needle-rollers in the bearing races and fill with grease. Should difficulty be experienced in retaining the rollers under control, smear the walls of the races with grease to Ref. D. (Section C) to retain the needle-rollers in position while re-assembling.

Insert the spider in the flange yoke, ensuring that **the lubricator boss is fitted away from the yoke**. Using a soft-nosed drift, about $\frac{1}{32}$ in. (.8 mm.) smaller in diameter than the hole in the yoke, tap the bearing into position. Repeat this operation for the other three bearings. Replace the circlips and be sure that these are firmly located in their grooves. If the joint appears to bind, tap lightly with a wooden mallet: this will relieve any pressure of the bearings on the end of the journals.

It is always advisable to replace the cork gasket and the gasket retainers on the spider journals by means of a tubular drift shown in Fig. 4. The spider journal shoulders should be shellacked prior to fitting the retainers to ensure a good oil seal.

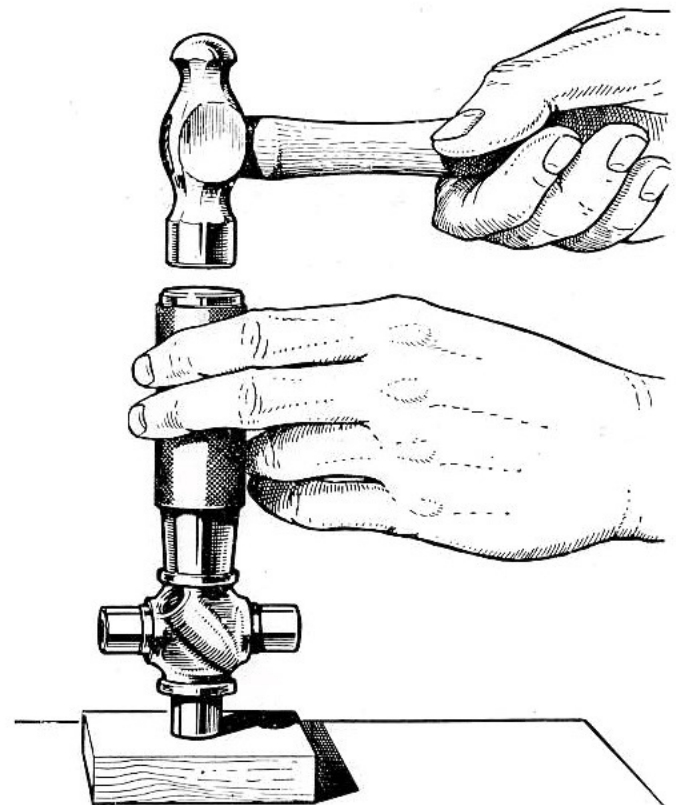

Fig. 4

When replacing the gasket retainer use should be made of a hollow drift to tap it into place without damage

8—REPLACING THE PROPELLER SHAFT

Replacement is the reversal of the procedure outlined above. It will be necessary however to remove the right hand seat and turn back the trim on the propeller shaft tunnel to expose the access hole. By simple manipulation it will be found possible to re-engage the propeller shaft splines with those of the gearbox tail shaft. Wipe the faces of the flanges clean, and ensure that the flange spigots engage correctly. Ensure that the components are replaced in exactly the same relation as before removal and that the joint faces bed down evenly all round. Insert the bolts and tighten the self locking nuts.

FILE NOT TO BE REDISTRIBUTED FOR PROFIT ORIGINAL COPYRIGHT HOLDER LOTUS CARS LIMITED 1966

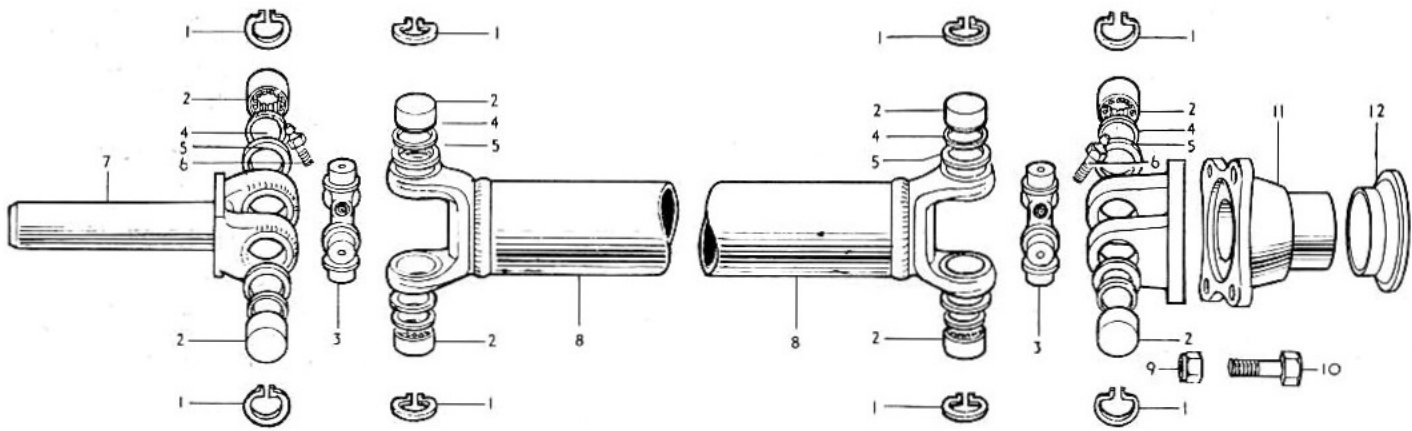

Fig. 5
Propeller Shaft Components

KEY TO PROPELLER SHAFT COMPONENTS

Key No.	Description	Key No.	Description
1	Snap ring (universal joint)	6	Greaser for universal joint
2	Bearing race assembly	7	Splined and sleeve knuckle (universal)
3	Universal joint spider	8	Propeller shaft
4	Seal (universal joint spider oil)	11	Flange (drive shaft assembly)
5	Retainer (universal joint spider oil)	12	Deflector (drive pinion oil seal dust)

SECTION I

REAR SUSPENSION, DIFFERENTIAL AND FINAL DRIVE

	<i>Chapter</i>
Rear suspension and differential <i>Illustration</i>	
Rear suspension and differential <i>Key to components</i>	
Rear suspension—general arrangement <i>Illustration</i>	
Removing the rear suspension	1
Lower wishbones—removal	2
Drive shafts—removal	3
Dismantling the hubs	4
Inspection	5
Re-assembly	6
Removing the differential assembly	7
Dismantling the differential unit	8
Dismantling the differential carrier assembly	9
Overhauling the differential carrier assembly	10
Replacing the differential unit	11

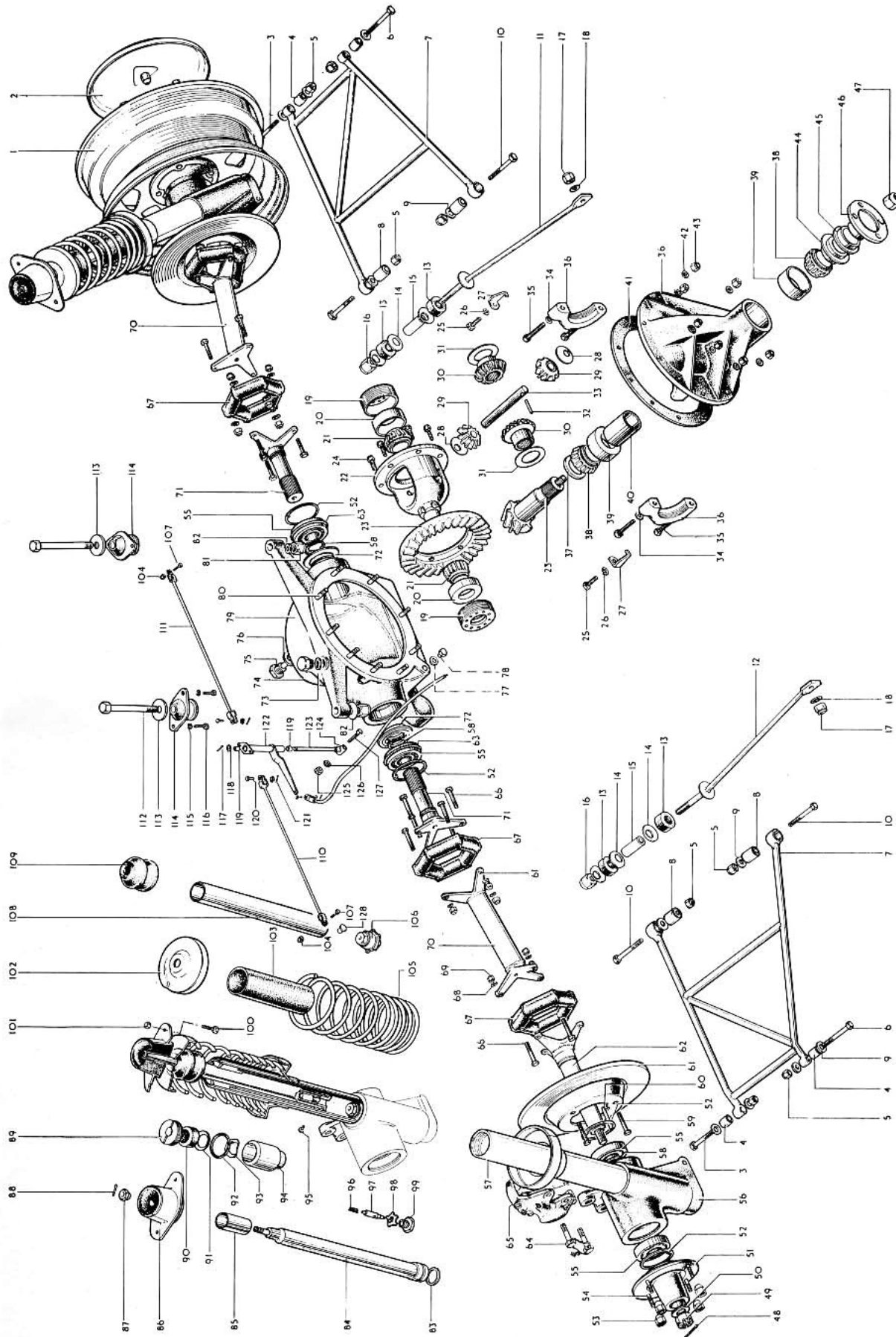

Fig. 1—THE REAR SUSPENSION AND DIFFERENTIAL ASSEMBLY

FILE NOT TO BE REDISTRIBUTED FOR PROFIT ORIGINAL COPYRIGHT HOLDER LOTUS CARS LIMITED 1966

KEY TO THE REAR SUSPENSION AND DIFFERENTIAL ASSEMBLY COMPONENTS

Key No.	Description	Key No.	Description	Key No.	Description
1	Road wheel 450J x 13	46	Flange (drive shaft) assembly	90	Gland (suspension unit piston rod)
2	Hub cap	47	Nut (U/J flange to rear axle)	91	Cup (suspension unit piston rod gland)
3	$\frac{1}{8}$ in. bolt	48	Split pin	92	Ring (suspension unit outer tube oil sealing)
4	Bush (Clatonrite)	49	$\frac{3}{8}$ in. Nyloc nut type "D" (Simmonds) cad. plate	93	Spring (suspension unit piston rod gland wave)
5	$\frac{1}{16}$ in. Nyloc nut type "T"	50	$\frac{3}{8}$ in. Plain washer cad. plate	94	Guide (suspension unit piston rod)
6	$\frac{1}{8}$ in. bolt	51	Hub rear	95	Plug (suspension unit filler)
7	Wishbone	52	Circle internal Anderton 62 mm.	96	Spring (suspension unit piston recuperating valve)
8	Metaltastic bush	53	Wheel nuts (standard motor)	97	Valve (suspension unit piston) and recuperating valve assembly
9	$\frac{1}{8}$ in. plain washer	54	Wheel studs (standard motor)	98	Washer (suspension unit piston recuperating valve screw)
10	$\frac{1}{8}$ in. bolt x $2\frac{1}{2}$ in. long cad. plate	55	Bearing LJ 30 WSRR Ransom and Marles or R.I.V.	99	Screw (suspension unit piston recuperating valve)
11	Torque rod L.H.	56	Bearing housing	100	$\frac{3}{8}$ in. set screw—Lotocone mounting
12	Mounting bush rubber	57	Damper unit—strut	101	Nut
13	Mounting bush washer	58	Circle external Anderton 30 mm.	102	Top spring abutment
14	Mounting bush spacer tube (earlier models only)	59	$\frac{1}{8}$ in. bolt x $3\frac{1}{4}$ in. long cad. plate	103	Dust cover
15	Nyloc nut	60	Key—rear hub	104	$\frac{3}{8}$ in. Nyloc nut type "T"
16	Nut	61	Disc rear	105	Road spring
17	Washer	62	Outboard drive shaft	106	Valve (suspension unit foot) and compression valve assembly
18	Nut (differential bearing adjusting)	63	Rubber "O" ring (differential bearing seal)	107	$\frac{3}{8}$ in. bolt x $\frac{3}{4}$ in. cad. plate
19	Cup (differential bearing)	64	Bolt—caliper mounting	108	Cylinder (suspension unit)
20	Cone (differential bearing) and roller assy.	65	Caliper rear	109	Aeon rubber
21	Case (differential gear)	66	$\frac{1}{16}$ in. bolt x 3 in. long cad. plate	110	Actuating rod handbrake R.H.
22	Gear (rear axle driving) and pinion assembly	67	"Rotflex" coupling	111	Actuating rod handbrake L.H.
23	Bolt (differential case to driving gear)	68	Special washer	112	$\frac{3}{8}$ in. bolt $3\frac{1}{4}$ in. long
24	Bolt (differential bearing adjusting nut lock)	69	$\frac{1}{16}$ in. bolt x Nyloc unit type "T" cad. plate	113	$\frac{3}{8}$ in. washer (large)
25	Lockwasher	70	Fixed length drive shaft	114	Top mounting (Silentbloc)
26	Lock (differential bearing adjusting nut) R.H.	71	Inboard drive shaft	115	Spring washer
27	Washer (differential pinion thrust)	72	Gaco sealing ring	116	$\frac{1}{16}$ in. bolt x $\frac{3}{4}$ in. long
28	Pinion (differential)	73	Differential breather gasket	117	$\frac{1}{16}$ in. split pin $\frac{3}{8}$ in. long
29	Gear (differential)	74	Oil breather	118	Washer
30	Washer (differential gear thrust)	75	Filler and level plug $\frac{1}{2}$ in. B.S.P.	119	Oilite bush $\frac{3}{8}$ in. long
31	Pin (differential pinion shaft lock)	76	Filler and level plug $\frac{3}{8}$ in. fibre washer	120	Clevis pin (Bowden)
32	Shaft (differential pinion)	77	$\frac{1}{4}$ in. B.S.P. drain plug (early models only)	121	$\frac{1}{16}$ in. split pin x $\frac{3}{8}$ in. long
33	Lockwasher	78	$\frac{1}{4}$ in. fibre washer (early models only)	122	Lever tube
34	Bolt (rear axle differential cap to carrier)	79	Differential housing	123	Lever spindle
35	Carrier (rear axle differential) assembly	80	Stud—differential housing to carrier $\frac{3}{8}$ in.	124	Distance tube
36	Shim (drive pinion bearing adjusting)	81	$\frac{3}{8}$ in. Nyloc type "T"	125	$\frac{3}{4}$ in. Nyloc nut type "T" (Simmonds)
37	Cone (driving pinion bearing) and roller assy.	82	$\frac{3}{8}$ in. washer (plain)	126	$\frac{3}{4}$ in. plain washer
38	Cup (driving pinion bearing)	83	Ring (suspension unit piston)	127	$\frac{1}{4}$ in. bolt x $2\frac{1}{4}$ in. long
39	Spacer (driving pinion bearing)	84	Piston (suspension unit) and rod assembly	128	Bush for caliper lever
40	Gasket (differential housing to carrier)	85	Tube (suspension unit rebound stop)		
41	Lockwasher	86	Resilient mounting assembly Lotocone		
42	Nyloc nut	87	Nut—resilient mounting to damper unit		
43	Seal (drive pinion oil) assembly	88	$\frac{3}{8}$ in. split pin x $1\frac{1}{2}$ in. long		
44	Deflector (drive pinion oil seal dust)	89	Cap (suspension unit piston rod gland)		

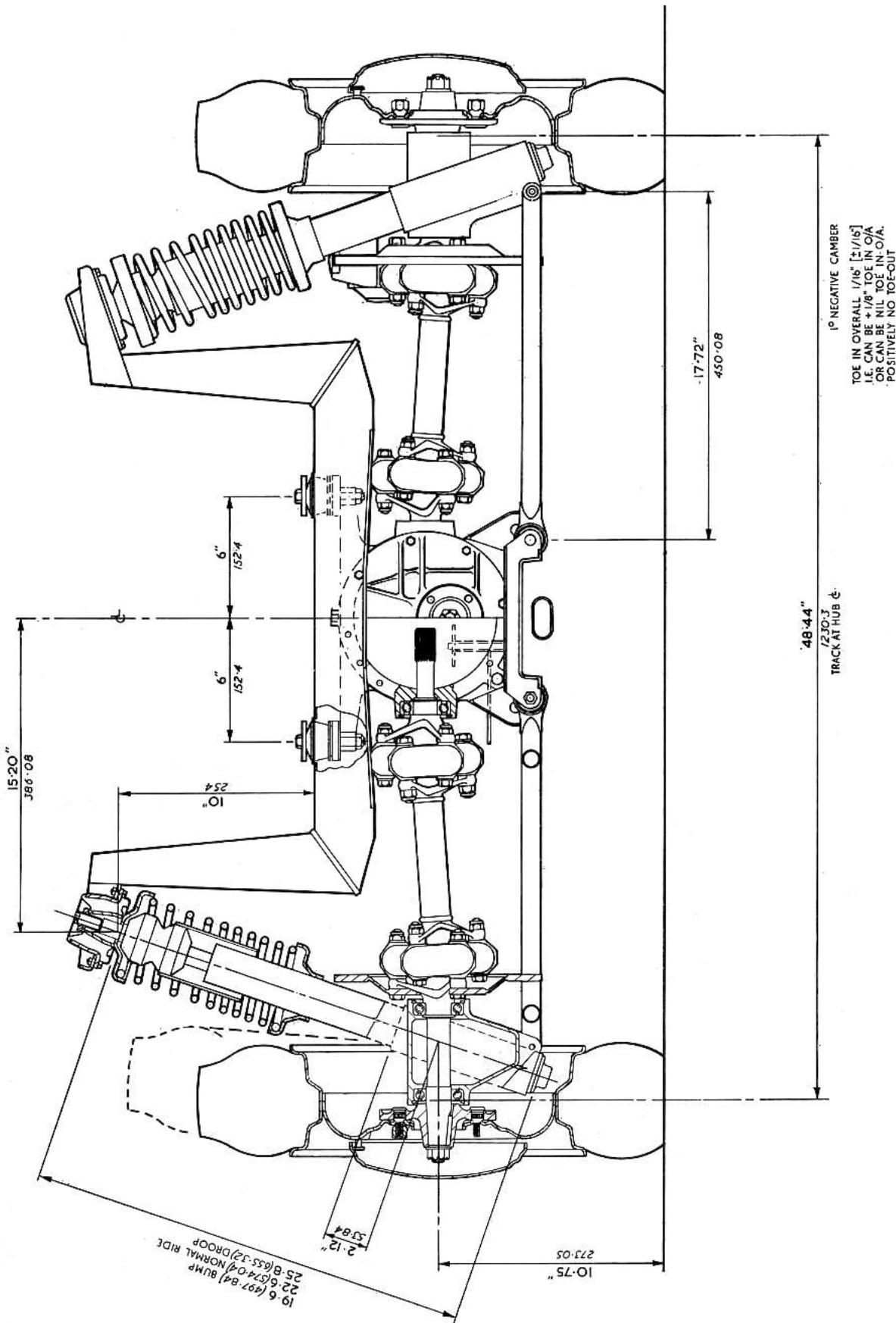

Fig. 2—GENERAL ARRANGEMENT—REAR SUSPENSION

FILE NOT TO BE REDISTRIBUTED FOR PROFIT ORIGINAL COPYRIGHT HOLDER LOTUS CARS LIMITED 1966

1—REMOVING THE REAR SUSPENSION

Jack up rear of car.

Remove rear wheel disc, nuts and road wheel.

Place a second jack under the strut housing taking care to ensure that the crutch of the jack is properly located under the housing, and jack up to assume the normal load of the car on the suspension strut.

Secure the spring with suitable clamps or leather straps. Undo the three $\frac{7}{16}$ in. Nyloc nuts holding the Rotoflex coupling to the rear axle differential shaft and withdraw the 3 in. bolts. Undo the $\frac{7}{16}$ in. Nyloc nuts and withdraw the bolts locating the lower wishbone to the strut housing.

Slacken the inner wishbone to chassis mounting bolts and allow the wishbone to lower itself about these points.

Remove the rubber cap on the top decking of the boot behind the seat, remove the split pin and castellated nut of the rear suspension strut. Lower the suspension unit (less complete lower wishbone) to floor.

2—LOWER WISHBONES—REMOVAL

To remove the lower wishbone, undo the two $\frac{7}{16}$ in. Nyloc nuts on the bolts holding the wishbone at its chassis attachment points. Withdraw the back bolt of the wishbone rearwards and tap the front bolt forwards through the wishbone eye.

NOTE:—In replacing the wishbone it is advisable to insert the front mounting bolt from the rear of the wishbone eye and insert the Nyloc nut in the rather limited space available forward of the wishbone attachment point.

3—DRIVE SHAFTS—REMOVAL

Remove the caliper from the mounting plate by undoing the two wire locked mounting bolts.

Remove the Rotoflex coupling adjacent to the disc, by undoing the three bolts that pass through the brake disc and the spider and withdraw the drive shaft complete with inner and outer Rotoflex couplings. Dismantle both couplings, this is completed by undoing the six bolts holding the three couplings to either end of the shaft.

4—DISMANTLING THE HUBS

Remove the bearing retainer circlip behind outboard drive shaft spider. Undo the $\frac{5}{8}$ in. Nyloc nut on the outboard drive shaft and remove the two spacing washers.

Using a suitable hub drawer, pull the hub off the taper and keyed end of the outboard driveshaft.

The outboard driveshaft can now be pulled inwards through the strut housing. It will be found that the inner bearing will come away with the shaft and may be separated by undoing the circlip and gently tapping off the shaft. Remove the outer bearing retainer circlip, and by using a suitable drift tap out the outer bearing from the inner side of the strut housing.

5—INSPECTION

Before the re-assembly it is advisable to thoroughly clean and inspect all components for wear or accidental damage. A check should be made for possible misalignment, fractured welds, etc., and replace any components wherever necessary.

Examine the Rotoflex couplings for any signs of cracking or mechanical breakdown of the rubber and renew if necessary.

All "Metalastic" bushes should be checked for wear and again renewed if necessary.

Hub bearings should be inspected for wear and it is advisable to fit new ones should the tolerances be excessive. Replace only with the recommended sealed bearings Lotus Part No. ALN 30.

6—RE-ASSEMBLY

Re-assembly of either rear suspension unit is a matter of reversal of the dismantling procedure outlined in the foregoing chapters. Brakes of course must be bled as described in section K chapter 10 after any suspension dismantling procedure.

7—REMOVING THE DIFFERENTIAL ASSEMBLY

Removal of this unit is facilitated if the vehicle is supported on suitable chassis stands.

Remove rear wheel discs, nuts and road wheels.

Remove the rubber cap on the left-hand side of the body decking to gain access to the top mounting of the suspension strut.

Remove the split pin and slacken the nut on the top of the suspension strut.

Undo the three bolts on each spider to release the Rotoflex coupling on either side of the differential unit.

Release the clevis of the hand brake push/pull rod on the left-hand caliper.

Undo the two bolts that pass through the outer ends of the lower wishbone and strut housing. Slacken off the inner bolts at the attachment points of the lower wishbone to chassis.

Disconnect the propeller shaft from the differential pinion drive flange by undoing the four $\frac{5}{16}$ in. U.N.C. nuts and bolts. Lift up the carpet of the boot and undo the two $\frac{3}{8}$ in. Nyloc nuts and remove the washers of the differential mounting bolts.

NOTE:—Earthing wire is attached to the right-hand mounting bolt. Release the differential torque stabilising rods on either side of the unit by removing the nut at the rear of each "Metalastic" bush and the $\frac{5}{16}$ in. nut locating the rod to the stud welded to the chassis. Ease the unit out from the left-hand side.

8—DISMANTLING THE DIFFERENTIAL UNIT

Drain the oil from the unit.

Remove the circlip on either side of the outer bearing housing and gently tap out each drive shaft.

Remove the bolts holding the differential carrier assembly to the bearing housing and lift out the differential carrier assembly complete with the crown wheel and differential assembly.

9—DISMANTLING THE DIFFERENTIAL CARRIER ASSEMBLY

Unscrew the bolts of the adjustment nut locking plate. Detach the plates. Note carefully that the bearing caps are marked for mating purposes and slacken the bearing cap bolts. Back off the differential bearing adjustment nuts using the special creeper spanner (Ford Tool No. P.4079) and detach the bearing caps after removing their bolts and lockwashers.

The crown wheel assembly can now be carefully removed complete with bearings and adjustment nuts. (Note that each bearing should be kept with its corresponding cup). Using a special spanner (Ford Tool No. P.4028) unscrew the nut securing the drive pinion to the propeller shaft coupling flange, after carefully removing the staking from the flange. Withdraw the coupling flange from the pinion shaft. The pinion complete with its rear bearing assembly and spacer can next be withdrawn from the rear of the housing. Remove the pinion bearing cups and drive the front bearing and oil seal forwards out of the housing. It is suggested the Ford Tool No. P.4015 be used for this purpose. Drive out the remaining rear pinion bearing cap from the front of the housing.

To dismantle the pinion assembly it is firstly necessary to remove the spacer from the shaft in the following manner.

Using Ford Tool No. P.4000-28 insert the rims of the adapter segments behind the bearing cone. Place the unit

and tool on the bed of a suitable hand press. Make sure that the bearing cage is not fouling and press out the pinion.

To dismantle the crown and differential assembly, unscrew the lock bolts securing the crown wheel to the differential cage. Press the cage through the crown wheel. Drive out the taper pin situated in one end of the spider shaft away from the crown wheel side of the cage. Push the differential pinion shaft through the cage and extract the two pinions. Remove the conical thrust washers at the same time. Withdraw the two axle shafts gears and their thrust washers from the cage. Using Ford Tool No. P.4000-27A locate its adapter flanges around the differential bearing cone, support the assembly on the bed of a hand press and press off the bearing cones taking care that the roller cage is not damaged in the process. Clean all components and inspect for wear or damage, replacing where necessary.

10—OVERHAULING THE DIFFERENTIAL CARRIER ASSEMBLY

Re-assembly is basically a reversal of the procedure above. However, where new components have been included, it should be noted that our adjustment will be affected. Care must therefore be exercised in re-assembly to obtain (a) the correct pinion bearing engagement by using the correct shim (b) the correct pinion bearing pre-loading (c) the correct crown wheel and previous backlash (d) the correct differential bearing pre-loading.

11—TO RE-ASSEMBLE THE DIFFERENTIAL CAGE

Lubricate the thrust washers and place them on the rear faces of the axle shafts gears. Insert the gears in the differential cage, lubricate the conical thrust washers and locate behind each differential pinion. Place the pinions in the apertures of the cage diametrically opposite each other and rotate the axle shaft gears so that the hole for the spider shaft in the cage aligns the pinions.

Insert the spider shaft after making sure that the taper pin hole will line up with its corresponding hole in the cage. Push the spider shaft home and insert the taper pin from the differential side of the case. Drive the taper pin home and lightly peen over the cage.

Locate the crown wheel on the cage and enter three bolts through the wheel and cage and press on using a suitable hand press and special differential bearing cone driven Ford Tool No. P.4080. Remove the three bolts used as pilot guides and replace with six lock bolts tightening them to 30—35 lb.ft. (4.148 to 4.839 kg.m.). Press the differential driving cones into the cage using the same Ford Tool No. P.4080.

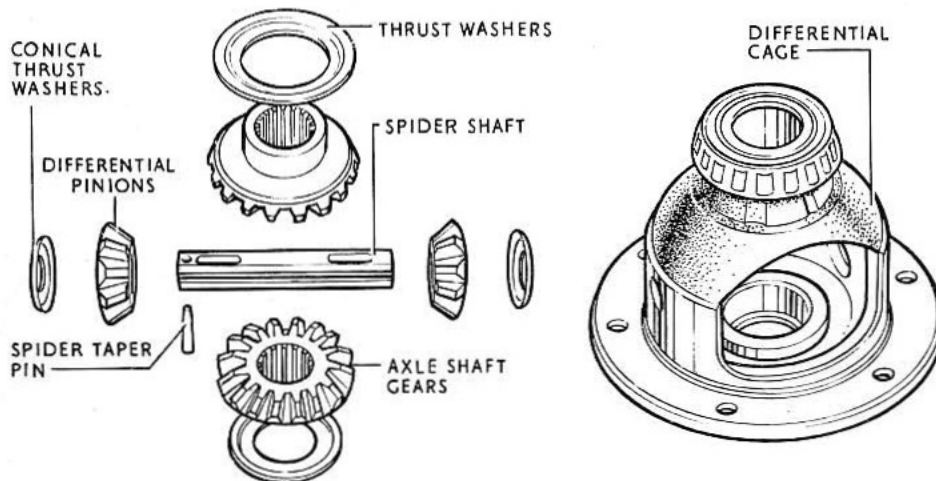

Fig. 4 Differential Assembly — Exploded

To fit the pinion bearing cups place the rear one on Ford Tool No. P.4013-3 and insert through the carrier from the rear. Place the front bearing cup, followed by loose adapter and wing nut to the centre bolt of the tool now protruding from the front of the carrier. Tighten the wing nut pressing both cups fully home. Unscrew the wing nut and remove the tool. To select the correct shim to control the pinion bearing engagement, the following procedure must be adhered to.

Using special Ford Tool No. P.4075-4 (in effect a driving pinion) slide the rear bearing onto its location—the larger diameter of the bearing being towards the pinion flange and fit the assembly to the differential carrier. Slide the front bearing cone with its smaller diameter inwards onto the tool and fit the drive shaft flange onto the pinion shaft splines. Fit the old pinion drive flange nut. Pre-load the pinion bearings by holding the drive flange with the special Ford Tool No. P.4028 and tighten the flange nut, whilst turning the pinion backwards and forwards to ensure the bearing rollers are seating correctly. Continue this operation until the rotation indicates that the bearings are correctly seated by an even bearing drag. Fit the pre-load gauge (Ford Tool No. CP 4030) with pinion bearing at pre-loaded running torque of between 9 and 11 lbs. (0.104 to 0.127 k.g.m.). Should this pre-loading be exceeded, then slacken the flange nut to relieve bearings of any pre-loading and re-tighten to correct setting.

The depth of engagement between pinion and crown wheel is dependent on the insertion of a suitable shim between the rear pinion bearing cone and the front face of the pinion. A depth gauge tool (Ford Tool No. P.4075-3) in conjunction with adapters (Ford Tool No. P.4075) is used to determine the correct thickness of the shim required.

Set the gauge to zero by operating the setting button beneath the tool and turn dial to zero. Ensure that the bearing locations are clean, set the tool so that the gauge plunger rests on the upper face of the driving pinion tool and check that a minimum reading is obtained by rocking the gauge slightly backwards and forwards.

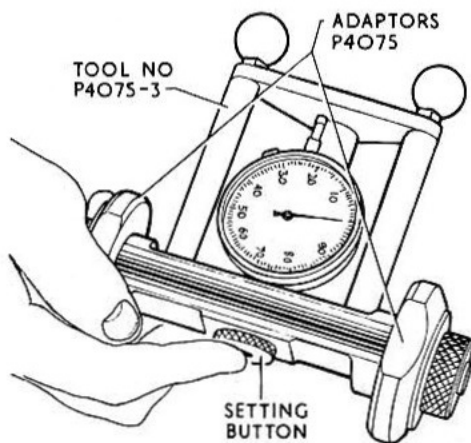

Fig. 5 Zeroing the Depth of Mesh Gauge

To obtain the actual thickness of shim required it is necessary to add 0.10 in. (2.54 mm.) to the reading given by the gauge, i.e. a dial reading of 39 would require a shim of 0.139 in.

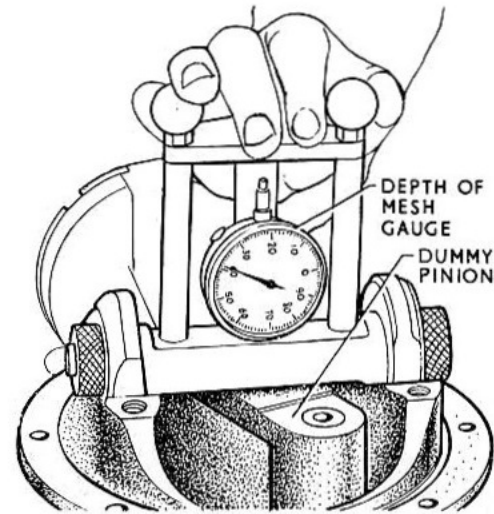

Fig. 6 Checking Pinion Depth of Mesh

It should be mentioned at this juncture that etched markings may exist on the taper portion of any pinion shaft between the two bearing locations. This will affect the shim thickness accordingly and where the figure exists with a plus sign it should be added to that of the gauge figure, or in the case of a minus sign subtracted from the reading.

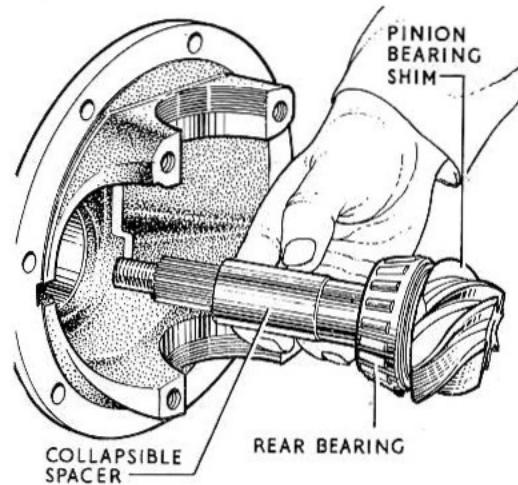

Fig. 7 Assembling the Pinion

Dismantle the driving pinion tool and unscrew the pre-load gauge adapter nut, pull off the drive flange and front bearing cone and remove driving pinion and rear bearing cone from the rear of the housing. Fit the selected shim with the internal chamfer on the shim towards the gear teeth with the aid of Ford Tool No. P.4000-28 press the bearing home on the pinion. Assemble the front pinion

bearing cone and cup and locate the oil seal in the axle throat with its lip towards the bearing. Press the seal home using Ford Tool No. 4013-3. Oil the seal slightly and fit the pinion into the front pinion bearing complete with a new collapsible spacer see Fig. 7. Having replaced the drive flange retaining nut tighten the nut until there is very little end float on the pinion shaft. Check the torque required to rotate the assembly and add this figure to the pre-load figure of 9—11 lbs. in. 104—0.127 kg. in for the pinion bearing above. The pinion must be rotated continually whilst the drive flange retaining nut is being tightened to the correct reading to ensure correct seating of the bearing rollers. If the pre-load is exceeded the assembly must be dismantled and a new spacer fitted to the pinion. Once the correct loading had been obtained lock the drive flange retaining nut to the pinion with several blows of a suitable punch.

Correct tooth contact depends upon the adjustment of the crown wheel and pinion backlash and differential bearing pre-load. Locate the differential bearing cups on their cones and position the assembly on the carrier housing ensuring that the bearing cups are square on the rollers.

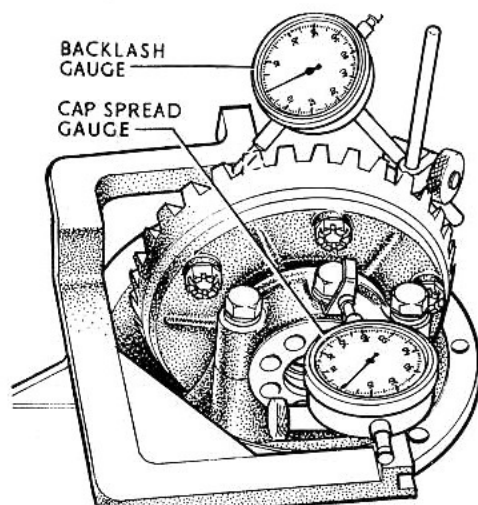

Fig. 8 Cap Spread and Backlash Gauge

Bolt the bearing caps in place ensuring that the mating marks correspond but do not fully tighten at this stage. Refit the differential bearing adjusting nuts.

To fit the bearing cap spread gauge (Ford Tool No. P.4009) bolt one of the adjusting nut locking plates upside down on the bearing cap. Locate the plunger of the gauge on the vertical face of the locking plate. Set the gauge at zero and tighten the bearing adjusting nuts until there is only slight backlash between the crown wheel and pinion. Rotate the crown wheel during this operation to ensure the correct seating of the bearing rollers. Bolt the backlash gauge (Ford Tool No. P.4008-1) to the differential carrier flange so that the gauge plunger may be rested on the heel of a crown wheel tooth and perpendicular to it. Having set the gauge at zero adjust the backlash by means of the differential bearing adjustments to a reading of between 0.001 to 0.002 in. (0.025 in.—0.0050 mm.). The last one to be tightened is the nut on the crown wheel side. Moving the backlash

gauge aside screw in the bearing adjusting nut on the differential side until a constant cap spread reading of 0.005—0.007 in. (0.127—0.178 mm.) is obtained. Re-position the backlash gauge and holding the pinion rock the crown wheel to and fro. The final reading of the backlash between the crown wheel and pinion should be 0.005—0.007 in. (0.127—0.178 mm.). If the backlash is outside these limits readjustments should be made by slackening the adjusting nut on one side and tightening the adjusting nut on the other side by the same amount—final tightening always occurring on the crown wheel side. Fit the adjusting nut locking plates, tightening the retaining bolts to a torque of 12—15 lb.ft. (1.659—2.074 kg.m.) and the differential cap retaining bolts to a torque of 45—50 lbs.ft. (6.221—6.913 kg.m.).

To check the tooth contact of the crown wheel and pinion apply a thin coat of red lead or yellow ochre to the crown wheel teeth. Fit the axle shafts to the differential gears and rotate the pinion in both directions, holding the axle shafts to provide a load. If the crown wheel and pinion have been adjusted correctly the area of contact will be as shown in fig. 9.

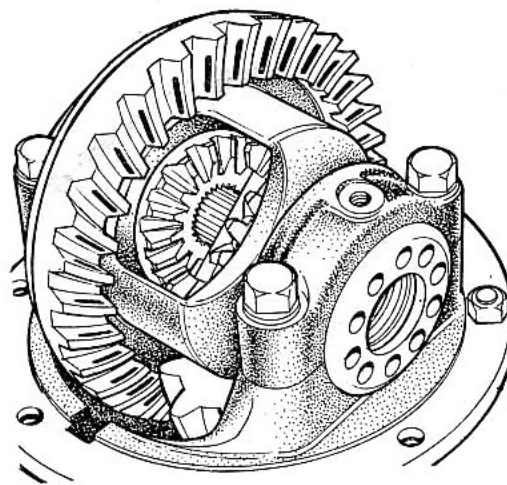

Fig. 9 Correct Tooth Marking

Assembly sequence of dowel type differential unit. The dowel method of differential assembly was introduced on car No. 492 approximately. Replacing the differential carrier in the differential casing, Lotus Part No. A 26 R 004. Replacement follows a reversal of the dismantling procedure. Later assemblies have the nose piece located positively by means of dowels. Earlier assemblies need to be put together with great care. A trial assembly should be made with a standard gasket having a thickness of 0.009—0.011 in. (0.229—0.279 mm.). Insert the in-board drive shafts with bearings and check the shafts for concentricity in the differential casing by examining the bearing entry into the casing. Fore and aft adjustments are obtained by fitting the correct thickness gasket. Vertical adjustments are obtained by rotating the nose piece in the casing. When the shafts are truly central in the differential casing and can turn with the least effort the unit should be at its quietest.

NOTE:—When using replacement components.

New nose pieces must be drilled and reamed using jig No. 26 T 094 (Lotus) and two securing bolt holes enlarged to 0.340 in.—0.345 in. Two dowels part No. 26 R 013 must be driven into the nose piece using a new gasket part No. 26 R 014 and red hermatite. Check the nose piece for free movement. Clean the joint faces and smear them with red hermatite. Locate the gasket and casing in position and secure with eight $\frac{5}{16}$ in. U.N.C. hexagonal bolts—do not tighten at this stage. Fit the drive shafts and rotate them for freedom of movement. Finally tighten the bolts.

Required parts for differential assembly :—

Differential casing—A 26 R 004

Differential nose piece—26 R 702

Gasket—26 R 014

12—REPLACING THE DIFFERENTIAL UNIT

The procedure for assembly of the unit and replacing in the chassis is a reversal of the procedure outlined in the foregoing chapters. It is suggested that the differential unit be re-filled with oil, Ref. C. to the recommended level (i.e. 2 pints, 2.1 U.S. pints, 0.99 litres) prior to its replacement in the chassis.

Differential and hub bearing equivalents.

R&M: LJ30 W.S.R.R.

RIV: ALN30

SKF: SKF6206—2RS

SECTION J**FRONT SUSPENSION AND STEERING GEAR**

	<i>Chapter</i>
Front suspension—general arrangement <i>Illustration</i>	
Dismantling the front suspension	1
Dismantling the hub	2
Dismantling the wishbones	3
Dismantling the vertical link assembly	4
Inspection of components	5
Assembling the front suspension	6
Hub assembly	7
Final assembly and adjustment	8
Steering and suspension parts and general dimensions ... <i>Illustration</i>	
Front suspension and steering <i>Illustration</i>	
Front suspension and steering <i>Key to components</i>	
Rack and Pinion assembly	9

1—DISMANTLING THE FRONT SUSPENSION

Jack the front of the vehicle up and place on suitable chassis stands, taking care to chock the rear wheels. Remove hub disc, wheel nuts and road wheel. Replace wheel nuts to protect their thread and avoid loss.

Disconnect the brake hose at the caliper end.

Remove the Nyloc nut on the end of the steering arms, and separate the track rod end from the steering arm by using a suitable drawer tool. (The lower end of the tapered ball joint pin will be found to have an engagement centre for this purpose).

Remove the lock nut, nut cup, washers and rubber bush from the end of the anti-roll bar on both suspension units and lower the anti-roll bar about its chassis mounting points clear. Unscrew the two bolts holding the brake caliper to the caliper mounting plate and remove spring washers. Withdraw the caliper assembly from the disc.

Remove the dust cap. This is a push fit in the hub and can be extracted by gently tapping in an outwards direction round its periphery.

Remove the split pin and unscrew the slotted nut from the stub axle. Remove the thrust washer and withdraw the brake and hub assembly complete. The taper bearings and outer cones will come away with the assembly, as will the oil seal.

2—DISMANTLING THE HUB

Undo the four bolts holding the brake disc to the hub, remove the spring washers and separate the hub from the disc.

Remove the outer roller bearing inner member from the hub. Using a soft metal drift tap the inner roller bearing inner member and seal assembly out of the hub. Tap the outer rings of the outer and inner roller bearings from the hub.

3—DISMANTLING THE WISHBONES

Unscrew the two Nyloc nuts holding the top front and rear wishbone members to their chassis mounted pivot points and reverse the washers. Unscrew the nuts of the two bolts clamping the front and rear top wishbone to the upper ball joint assembly. Remove washers and withdraw the top wishbone halves. Unscrew the two Nyloc nuts and remove the bolts clamping the lower wishbone halves to the trunnions assembly and the lower end of the spring damper unit.

Unscrew the two Nyloc nuts holding the front and rear lower wishbones members to their chassis mounted pivot points. Remove the washers and withdraw the two lower wishbone halves off their pivot points.

With a suitable press, remove the Clatonrite bushes from the inner ends of the upper wishbones halves.

Remove the Clatonrite bushes from the inner ends of the lower wishbone halves.

Undo the locknuts at the top of the spring damper unit mounting and remove cup washers and rubbers, taking note of their sequence for replacement purposes.

The spring damper unit will now come away from the chassis.

4—DISMANTLING THE VERTICAL LINK ASSEMBLY

To remove the disc brake dust cover from the vertical link assembly undo the two Nyloc nuts holding the steering arm to the vertical link. Withdraw the two bolts from the dust cover side and remove the steering arm through its slot in the vertical link. Undo the two upper bolts holding the dust cover to the link assembly and separate the caliper mounting bracket that is sandwiched between the dust cover and vertical link.

Unscrew the vertical link from the bronze trunion and withdraw the seal.

NOTE:—The vertical link and bronze trunion on the left-hand side of the vehicle has a left-hand thread and those fitted to the right-hand side of the vehicle have a right-hand thread. The right-hand threaded trunion is turned down at its lower end for identification purposes.

Remove the steel sleeve, two rubber rings and the two nylon bushes from the trunion.

Remove the Nyloc nut and washer and then, utilizing a suitable press, separate the vertical link from the tapered pin of its ball joint that was held between the outer halves of the upper wishbones.

Undo the Nyloc nut and plain washer and with a suitable press separate the stub axle from the vertical link.

5—INSPECTION OF COMPONENTS

Clean all components thoroughly.

Inspect the roller bearings for blueing, pitting, scoring or any other damage.

Inspect the outer ring bearing tracks and seal retainer sealings in the hub and remove any protrusions.

Examine all nylon and rubber bushes for wear.

Inspect ball joint assemblies, stub axle, threads, etc. for wear or defect and replace where necessary.

If the car has suffered any impact it cannot be over emphasised that the inspection for cracks, broken welds or misalignment of parts is vital.

It should be ascertained that there is no misalignment in the suspension geometry prior to dismantling. A check to this end should be made using the general arrangement of the front suspension shown in this section. Reference should also be made to the vertical link and wishbone drawings for dimension checks on dismantling.

Should the spring damper unit be defective this unit should be returned to the factory for an exchange unit.

6—ASSEMBLING THE FRONT SUSPENSION

Utilising a suitable press and a piloted tool, press the rubber bushes into the eyes at the inner ends of the upper wishbone until they protrude equidistantly either side of the wishbone eyes.

Insert the stub axle into the vertical link with the split pin hole in its outer end horizontal relative to its fitted position. Fit the washer and Nyloc nut that secures the stub axle to the vertical link and tighten the nut to 55—60 lb. ft. (7.6—8.3 m.k.g.).

Fit the rubber seal to the vertical link, screw the vertical link into the bronze trunnion as far as possible, then unscrew it to the first working position, i.e. so that it does not bottom when the road wheel is turned to full front or back lock.

Fit the Clatonrite bushes to the edge of the inner end of the front and lower rear wishbones half.

Fit the Clatonrite bush to the eye of the inner end of the front and rear upper wishbone half.

Attach spring damper unit to top chassis mounting point interposing rubbers and cup washers in their correct sequence.

Fit front and rear top wishbone halves onto chassis pivot points at their inner ends and place washers and Nyloc nuts in position. Do not tighten. (See special note Final Assembly). Fit front and rear lower wishbone halves into chassis pivot points at their inner ends and place Nyloc nuts into position. Do not tighten.

Insert bolt through front of lower wishbone to engage with final assembly bottom location point of spring damper unit and clamp to rear wishbone half. Replace Nyloc nut at rear but do not tighten.

Insert the tapered pin of the bail joint, held between outer ends of the upper wishbone, into the tapered hole in the top of the vertical link, retain in position with the washer and Nyloc nut tightening nut to 38—42 lb. ft. (5.3—5.8 m.k.g.).

Insert the ball joint assembly between the outer ends of the upper wishbone halves and retain in position with two bolts, fitted from front, washers and Nyloc nuts, tighten nuts to 16—18 lb. ft. (2.2—2.5 m.k.g.).

Fit the two nylon bushes, the steel sleeve and two rubber rings to the bronze trunnion.

Insert the bronze trunnion between the outer ends of the lower wishbone and retain in position with the bolt, washer and Nyloc nut, tightening the nut to 42—46 lb. ft. (5.8—6.4 m.k.g.).

Tighten lower spring damper location nut to 42—46 lb. ft. (5.8—6.4 m.k.g.).

Fit dust cover and caliper mounting plate to vertical link by the two upper bolts to the vertical link. Pass steering arm through vertical link eye and clamp to assembly by passing the two lower bolts through the dust cover caliper, mounting plate vertical, link and steering

arm respectively. Tighten up the two Nyloc nuts on steering arm side to 30—35 lb. ft. (4.14—4.83 k.g.m.) and the two bolts on disc side to similar torque wrench settings.

7—HUB ASSEMBLY

Bolt disc to hub using torque setting of 30—34 lb. ft. (2.07—2.49 k.g.m.).

Carefully press the roller bearings outer rings into the hub until they contact their respective seatings.

Pack the space between the outer rings with a recommended grease, and smear grease over the outer rings.

Coat the rollers of the inner roller bearing inner member with grease and insert it into its outer ring.

Carefully tap the felt seal retainer assembly on to its seating, retainer leading.

Fit the hub assembly on to the stub axle.

Coat the rollers of the outer roller bearing inner member with grease and insert it into its outer ring in the hub.

Fit the washer and slotted nut leaving the nut finger tight.

Fit disc brake caliper and reconnect hose.

Bleed brakes as per section.

Insert tapered steering track rod end into eye of steering arm taking care that the rubber dust excluder has been replaced. Finally replace nut and tighten to 30—35 lb. ft. (4.15—4.84 k.g.m.).

8—FINAL ASSEMBLY AND ADJUSTMENT**Special Note**

It should be noted that before tightening the Nyloc nuts on the suspension attachment points to the chassis, i.e. those where the wishbones pivot about the Clatonrite bushes, the weight of the vehicle should be resting on its wheels in normal ride condition. This will avoid imposing undue torsional stresses on the bushes—a condition that could well arise should the nuts be tightened with the vehicle on chassis stands and the suspension assemblies in an extended attitude.

Adjustment of Hub Bearing

Whilst spinning the road wheel tighten the slotted nut to 5 lb. ft. (0.7 m.k.g.) then unscrew the slotted nut one flat to give 0.002 in. to 0.008 in. (0.05 mm. to 0.2 mm.) end float of the hub.

Fit the split pin and grease cap.

Jack up front of vehicle, remove chassis stands and lower vehicle to ground.

Check that the wheel nuts are tight then fit hub disc.

Fig. 1—WISHBONE—LOWER ASSEMBLY

- | | |
|---------------------------|--------------------------|
| (a) 1.25 in. (31.75 mm.) | (d) 2.00 in. (50.8 mm.) |
| (b) 1.375 in. (34.79 mm.) | (e) 7.00 in. (177.8 mm.) |
| (c) 1.81 in. (45.97 mm.) | (f) 1.25 in. (31.75 mm.) |

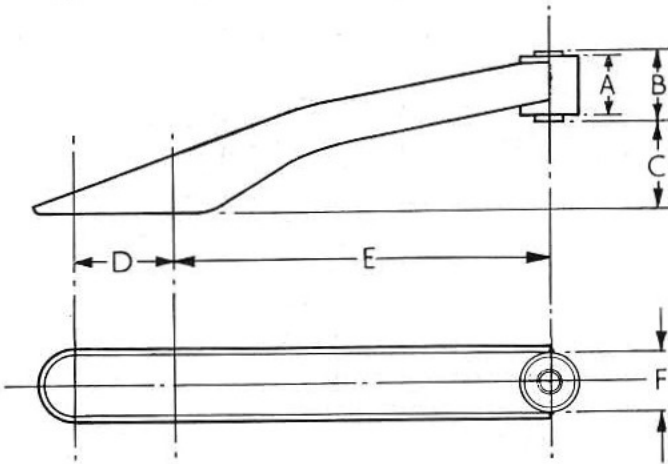

Fig. 2—WISHBONE—UPPER ASSEMBLY

- | | |
|---------------------------|--------------------------|
| (a) 1.25 in. (31.75 mm.) | (e) 1.50 in. (38.1 mm.) |
| (b) 1.375 in. (34.79 mm.) | (f) 0.44 in. (11.17 mm.) |
| (c) 1.81 in. (45.97 mm.) | (g) 1.25 in. (31.75 mm.) |
| (d) 5.00 in. (127.0 mm.) | |

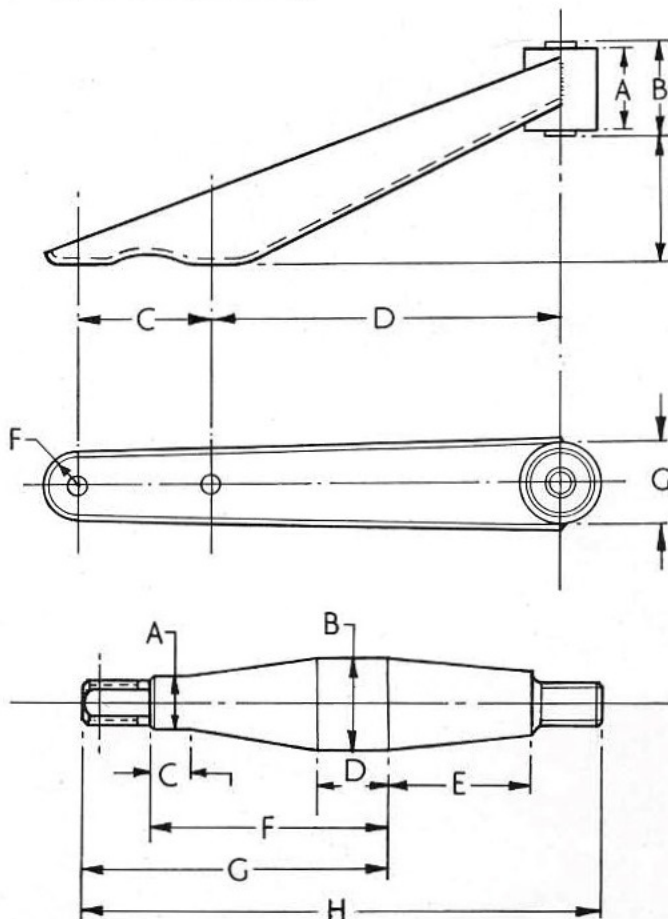

Fig. 3—VERTICAL LINK

- | | |
|----------------------------|---------------------------|
| (a) 1.83 in. (46.48 mm.) | (g) 45 degrees |
| (b) 0.335 in. (8.51 mm.) | (h) 0.13 in. (3.3 mm.) |
| 0.345 in. (8.76 mm.) | (i) 2.25 in. (57.15 mm.) |
| (c) 8½—9 degrees | (j) 4.44 in. (112.78 mm.) |
| (d) 0.245 in. (6.22 mm.) | (k) 3.12 in. (79.25 mm.) |
| 0.255 in. (6.48 mm.) | 3.13 in. (79.5 mm.) |
| (e) 4.565 in. (115.95 mm.) | (l) 1.936 in. (49.17 mm.) |
| (f) 0.963 in. (24.46 mm.) | 1.940 in. (49.28 mm.) |
| 0.973 in. (24.71 mm.) | |

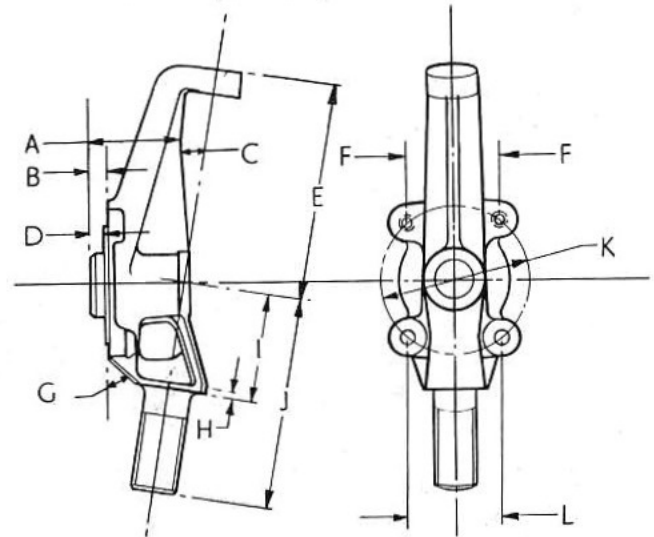

Fig. 4—R.H. STEERING LEVER

- | | |
|----------------------------|---------------------------|
| (a) 4.375 in. (111.13 mm.) | (e) 1.936 in. (49.17 mm.) |
| (b) 0.93 in. (23.62 mm.) | 1.940 in. (49.28 mm.) |
| (c) 0.33 in. (8.38 mm.) | (f) 0.31 in. (7.87 mm.) |
| (d) 0.307 in. (7.8 mm.) | (g) 0.5 in. (12.7 mm.) |
| 0.317 in. (8.05 mm.) | |

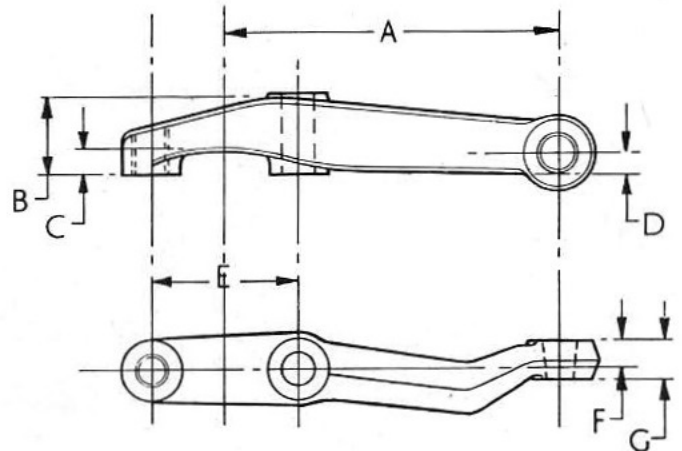

Fig. 5—STUB AXLE

- | | |
|----------------------------|--------------------------|
| (a) 0.6245 in. (15.86 mm.) | (d) 0.81 in. (20.57 mm.) |
| 0.625 in. (15.87 mm.) | (e) 1.66 in. (42.16 mm.) |
| (b) 0.9995 in. (25.37 mm.) | (f) 2.75 in. (69.85 mm.) |
| 1.0 in. (25.4 mm.) | (g) 3.53 in. (89.66 mm.) |
| (c) 0.56 in. (14.22 mm.) | (h) 6.00 in. (152.4 mm.) |

STEERING AND SUSPENSION PARTS—GENERAL DIMENSIONS

To assist in the assessment of accidental damage or misalignment, the dimensional drawings of certain parts are included.

FILE NOT TO BE REDISTRIBUTED FOR PROFIT ORIGINAL COPYRIGHT HOLDER LOTUS CARS LIMITED 1966

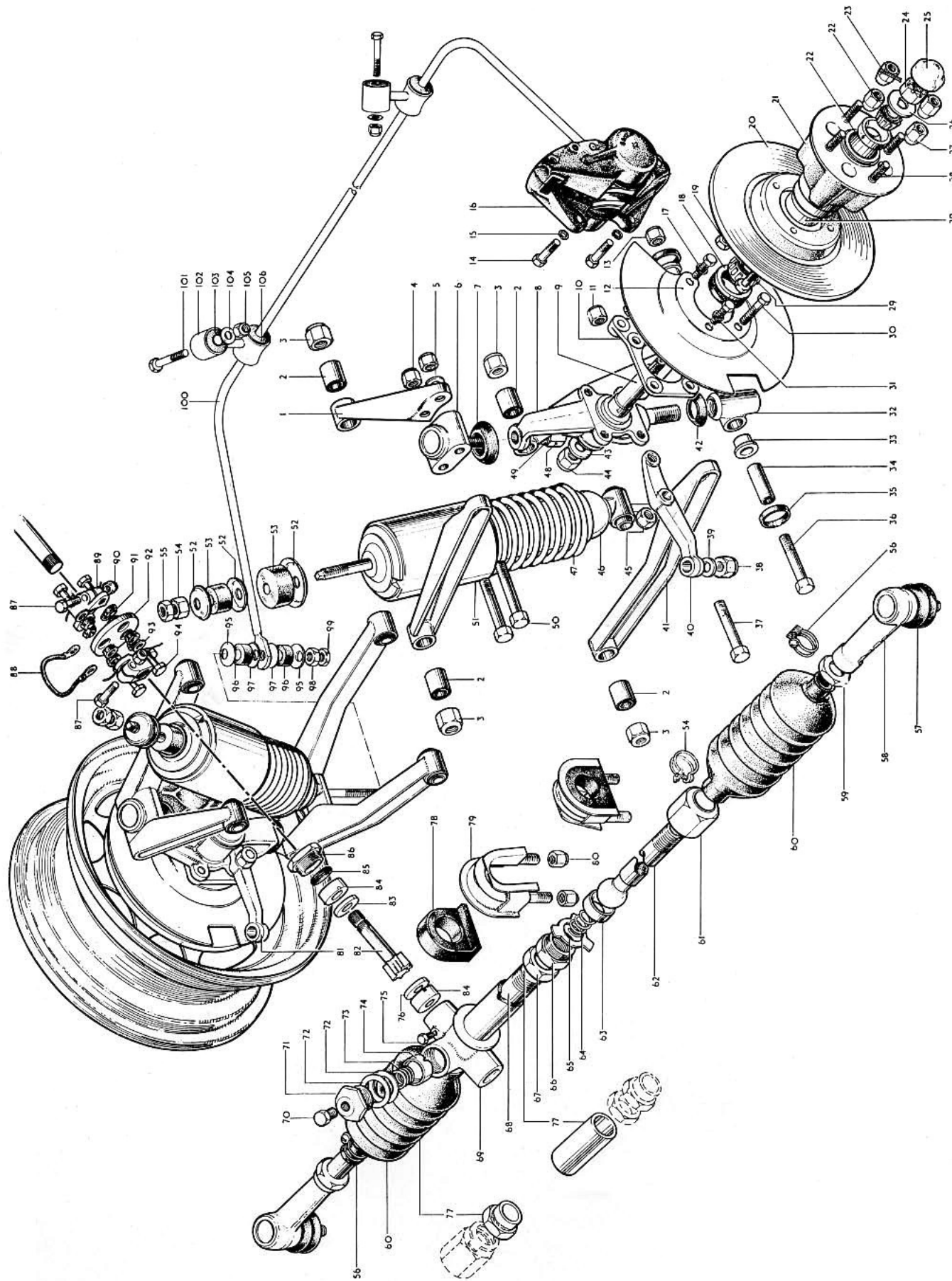

Fig. 7 FRONT SUSPENSION AND STEERING COMPONENTS

FILE NOT TO BE REDISTRIBUTED FOR PROFIT ORIGINAL COPYRIGHT HOLDER LOTUS CARS LIMITED 1966

KEY TO FRONT SUSPENSION AND STEERING COMPONENTS

Key No.	Description	Key No.	Description	Key No.	Description
1	Wishbone upper half	36	$\frac{7}{16}$ in. bolt x $2\frac{1}{2}$ in. long	73	Spring
2	Wishbone Bush (Clatonrite)	37	$\frac{1}{2}$ in. bolt x $2\frac{1}{4}$ in. long cad. plate	74	Pressure pad
3	$\frac{1}{2}$ in. Nyloc nut (Simmonds) wishbone pivot mountings cad. plate	38	$\frac{7}{16}$ in. Nyloc nut	75	Plug, grease
4	$\frac{1}{16}$ in. Nyloc nut (Simmonds) upper wishbone to ball housing	39	Plain washer	76	Thrust washer lower
5	$\frac{1}{16}$ in. plain washer	40	Steering arm L.H.	77	Steering top set comprising: Lock limiting stop (Pinion end) Lock limiting stop (Open end)
6	Upper ball joint assembly	41	Wishbone lower half	78	Rack mounting rubber
7	Upper ball joint seal	42	Trunnion upper seal	79	Rack mounting rubber housing
8	Vertical Link L.H.	43	$\frac{1}{2}$ in. Plain washer	80	$\frac{1}{16}$ in. Nyloc nut type "T" (Simmonds)
9	Stub axle shaft	44	$\frac{1}{2}$ in. Nyloc nut (Simmonds)	81	Steering arm R.H.
10	Caliper mounting plate L.H.	45	Front steering arm nut	82	Pinion
11	$\frac{7}{16}$ in. Nyloc nut	46	Damper	83	Thrust washer, upper
12	Dust cover L.H.	47	Road spring	84	Bush upper
13	$\frac{1}{2}$ in. Nyloc nut Type "T" (Simmonds)	48	Nut—ball joint to vertical link	85	Bush lower
14	Caliper mounting bolts	49	Plain washer	86	Rubber "O" ring seal
15	Spring washer	50	$\frac{1}{16}$ in. bolt x $2\frac{1}{4}$ in. long	87	Retaining nut
16	Caliper L.H.	51	Spring shroud	88	$\frac{1}{4}$ in. bolt x $1\frac{1}{4}$ in. long
17	Caliper mounting plate set screw	52	Cup washer	89	Earthing strip
18	Oil seal assembly	53	Mounting rubber	90	Steering coupling block
19	Disc mounting bolt	54	Locknut	91	$\frac{1}{4}$ in. Nyloc nut type "P"
20	Disc	55	Locknut	92	Rubber
21	Front hub	56	Clip	93	Steering coupling centre plate
22	Bearing assembly	57	Steering arm ball joint seal	94	Plain washer
23	Split pin $\frac{1}{8}$ in. dia. x 1 in. long	58	Ball joint assembly	95	Wire locking bolt
24	Slotted nut	59	Locknut	96	Cup washer
25	Dust cap	60	Gaiter	97	Mounting rubber
26	"D" washer	61	Cup nut	98	Cup washer
27	Wheel nut	62	Tie rod	99	Locknut type "P" (Simmonds)
28	Wheel stud	63	Thrust pad	100	Locknut type "T" (Simmonds)
29	Bearing, inner	64	Spring	101	Anti-roll bar and link assem. comp. : $\frac{3}{8}$ in. bolt x $1\frac{3}{4}$ in. long
30	Front steering arm bolt	65	Tabwasher	102	Anti-roll bar link
31	Spring washer	66	Sleeve nut	103	Rubber chassis
32	Trunnion assembly L.H.	67	Locknut	104	$\frac{3}{8}$ in. plain washer
33	Nylon bush	68	Rack	105	$\frac{3}{8}$ in. Nyloc nut
34	Steel sleeve	69	Rack tube and pinion housing	106	Rubber (anti-roll bar)
35	Rubber seal	70	Plug		
		71	Cap nut		
		72	Shim		

9—RACK AND PINION ASSEMBLY

Removal preparation

Open bonnet and disconnect the two springs holding it to the side rails and remove the component. Drain the radiator (the drain tap is accessible from beneath the body shell via an aperture). Jack up the front of the vehicle and support on chassis stands. Remove front hub discs, wheel nuts and road wheels. Remove radiator as outlined in Section N.

A simple inspection will reveal that the rack is clamped to the chassis at a location just below the radiator mountings and beneath the body structure itself. Room is extremely limited and to extract the unit the clamps must be withdrawn upwards through prepared slots in the body shell adjacent to the radiator mountings.

Owing to the longevity of the unit and the fact that maintenance is minimal provision for removal of these clamps as a design feature was unnecessary. However, in unforeseen circumstances such as those entailed through a crash, repair access slots may be cut.

These access slots must not exceed the dimensions shown in the accompanying illustration, and care must be exercised not to weaken the structure whilst cutting them.

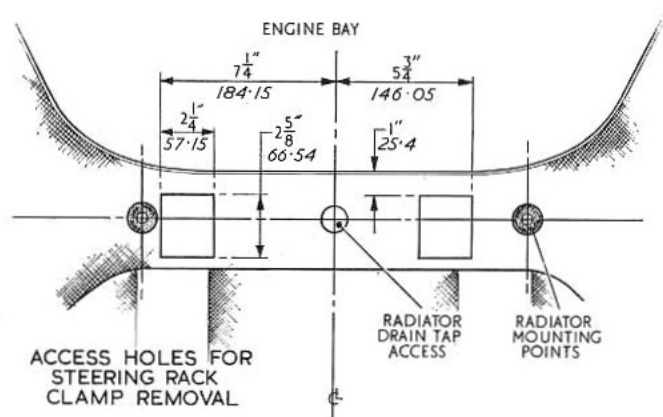

Fig. 8 Position and Dimensions of Access Slots

After cutting the above access slots remove the Nyloc nut and the bolt from the steering coupling. Remove the Nyloc nut and washer, then utilising a suitable press separate the outer tie rod ball joints from the steering levers. Remove the four Nyloc nuts on the steering rack "U" bolts and push them upwards through the slots in the body. The rubber mounting blocks may come away at this juncture or stay on the rack itself depending on their type. Remove the steering unit by moving it forward thereby disengaging the pinion shaft from the splined coupling, and draw the unit out from the pinion housing side.

Removal

1. Jack up the front of vehicle and support on chassis stands.
2. Open bonnet.
3. Remove hub discs, wheel nuts and road wheels.

4. Remove the Nyloc nut and the bolt from the steering coupling.
5. Remove the Nyloc nut and washer, then utilising a suitable press separate the outer tie rod ball joints from the steering levers.
6. Remove the four Nyloc nuts and the two "U" clamps that secure the steering unit to the chassis frame.

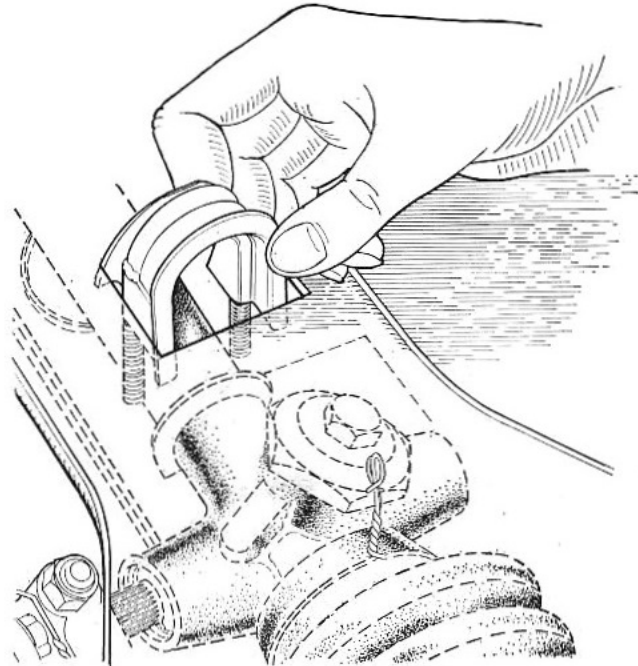

Fig. 9 Removing the "U" Clamps

7. Remove the steering unit by moving it forwards thereby disengaging the pinion shaft from the splined coupling.

Dismantling

1. Slacken the rubber gaiter retaining clips, pull the inner end of each gaiter from between the clip and rack tube, then slide each gaiter towards the outer ball joint.
2. Slacken the locknuts, and unscrew each outer tie rod assembly from the rack withdraw a coil spring from each end of the rack.
3. Turn back tabs of tabwashers then slacken and remove sleeve nut, tabwasher, and thrust pad, from each outer tie rod inner ball joint.
4. Slacken locknuts and unscrew each outer ball joint assembly from their respective tie rods.
5. Remove the locknut, rubber gaiter, clips, and cup nut from each outer tie rod.
6. Remove the locknuts and clips from each end of the rack.
7. Slacken and remove the cap nut, shim pack coil spring and pressure pad (early units). Remove circlip, invert unit and let locating pin fall out, remove cap, shim pack, spring, plate and pressure pad (later units).

8. Slacken and remove pinion retaining nut, shim pack and pinion shaft complete with bush and thrust washer.
9. Remove and discard the "O" ring seal from the retaining nut.
10. Withdraw the rack from the tube.
11. Remove thrust washer and bush from the pinion housing.

NOTE :—On later models, the pinion and pinion pressure pad assemblies are secured with circlips and pressure pad loading is maintained by a spring plate.

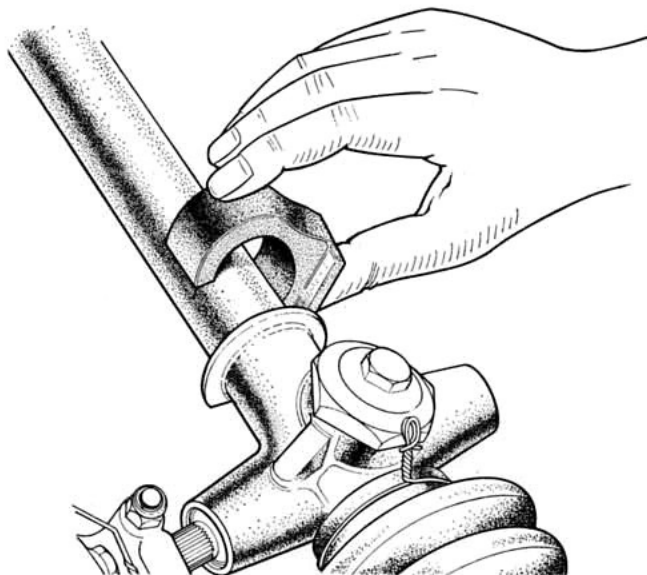
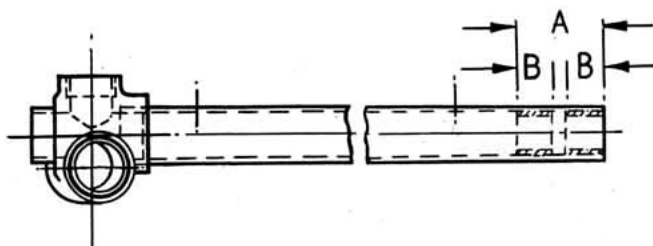

Fig. 10 Removing the Rubber Mounting Blocks

Inspection

1. Thoroughly clean all components.
2. Examine the bushes in the end of the rack tube for wear or damage. If necessary renew them, pressing the new bushes into the tube to the dimensions shown on Fig. 11.



1= 1.75 in. (44.45 mm.) 2= 0.75 in. (19.05 mm.)

Fig. 11 Rack Tube Bushes

3. Fit a new "O" ring seal to the pinion retaining nut.
4. Examine the rack and pinion for wear or damage, renew as necessary.
5. Examine the pinion thrust washers, and bushes for wear or damage, renew as necessary.

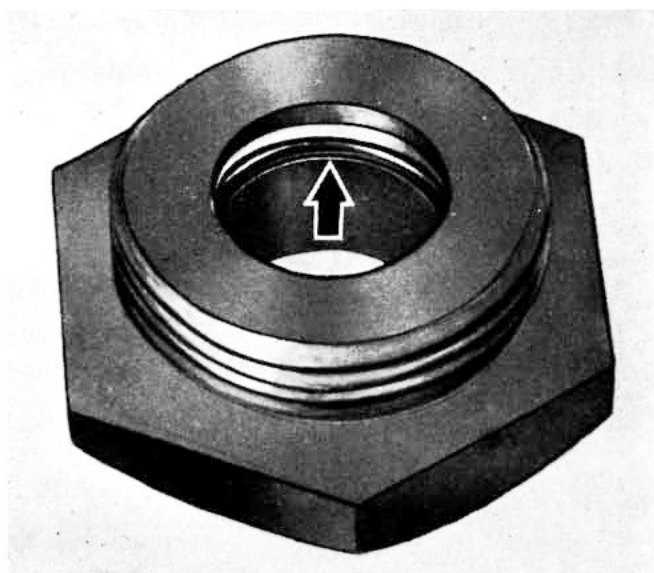

Fig. 12 The "O" Ring Seal in the Pinion Nut

6. Examine the thrust pad and inner ball joint of each outer tie rod for wear or damage. Renew as necessary.
7. Examine the outer ball joint assemblies for wear or damage. Renew as necessary.
8. Examine each cup nut for wear or damage, renew as necessary.
9. Check that the rack tube or outer tie rods are not bent. Renew as necessary.

Assembly

1. Insert bush and thrust washer into the pinion housing.
2. Insert the rack into the tube.



Fig. 13

Measuring the Pinion Nut Head/Pinion Housing Clearance

FILE NOT TO BE REDISTRIBUTED FOR PROFIT ORIGINAL COPYRIGHT HOLDER LOTUS CARS LIMITED 1966

3. Insert pinion with thrust washer and bush into pinion housing.
4. Adjust pinion end float on early units as follows:
 - (a) Fit the pinion nut (10) with an excessive amount of shims, screwing the nut until the pinion end float is just eliminated.
 - (b) Utilising feeler gauges ascertain the clearance between the inner face of the pinion nut head and pinion housing (Fig. 13.)
 - (c) Remove the pinion nut (10) and remove from the shim pack a number of shims equal in thickness to the pinion nut/pinion body clearance plus 0.008 in. (0.2 mm.).
 - (d) Leaving the remainder of the shims in position, fit and tighten the pinion nut. The pinion should now have 0.008 in. (0.2 mm.) end float. If the float is insufficient or excessive, remove or add shims as necessary.

Adjustment of pinion end float (later models).

5. Fit the pressure pad (74) and cap nut (71) screwing down the nut until pressure pad end float is just eliminated.
6. Utilising feeler gauges, ascertain the clearance between the inner face of the cap nut head and pinion housing.

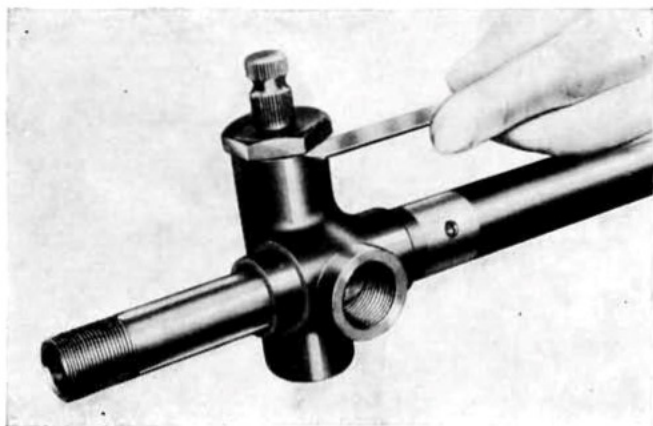

Fig. 14

Measuring cap nut head/pinion housing clearance

7. Obtain a shim pack equal in thickness to the cap nut/pinion housing clearance plus 0.004 in. (0.1 mm.)
8. Remove the nut cap (71) and fit the shim pack into its threaded shank.
9. Insert the spring into the pinion housing followed by the cap nut (71) tightening the nut. Replace the combined locknut and limit stop (77) of Lotus origin on the pinion side of the rack, with the nut outwards.
10. Fit the special Lotus part—the $1\frac{3}{4}$ in. long distance tube left-hand limit stop (77) on the other end of the

rack before replacing locknut (67). Fit a clip onto each end of the rack (68).

11. Smear the inside of each cup nut (61) with grease and fit them to their outer tie rods followed by the rubber gaiters (60) clips (56) and locknuts (59).
12. Screw the outer ball joint assemblies on to the outer tie rods until they assume the position shown on Fig. 33 then tighten locknut.
13. Fit a thrust pad (smear with grease) new tabwasher and sleeve nut to each outer tie rod inner ball joint. Tighten the sleeve nut, then bend over alternate tabwasher tabs to contact the sleeve nut and cup nut.
14. Insert a coil spring into each end of the rack. Screw each outer tie rod assembly onto the rack. Tighten locknuts.

NOTE:—Maximum lift of ball in cup to be 0.002 in. (0.05 mm.). Ensure that the ball joint moves freely.
15. Pull the inner end of each gaiter onto the rack tube and retain in position by tightening the clips. Tighten the clips that hold the gaiters to the outer tie rods.

Replacement.

1. Check that the steering unit conforms to the dimensions in Fig. 1.
2. Position the steering wheel in the straight ahead position.
3. Rotate the pinion shaft throughout its whole movement, from stop to stop, counting the number of revolutions. Rotate the pinion from a stop half the total number of revolutions, thereby centralising the rack in relation to the pinion.
4. Fit the steering unit, entering the splined pinion shaft into the splined coupling.
5. Fit the two rubber mountings (78) in their respective positions round the rack, taking care to replace with the "toe" facing inwards on both mountings.
6. Fit the two "U" clamps and four Nyloc nuts, tightening the nuts.
7. Enter the taper pins on the outer tie rod ball joints into the steering levers and fit the washers and Nyloc nuts. Tighten nuts to 26—28 lb. ft. (3.6—3.9 m.k.g.).
8. Fit the bolt and Nyloc nut to the steering coupling.
9. Fit road wheels and road nuts.
10. Replace bonnet and reconnect the springs.
11. Jack up the front of the vehicle, remove the chassis stands and lower the vehicle to the ground.
12. Check that the wheel nuts are tight then fit hub discs.
13. Check the front wheel alignment.

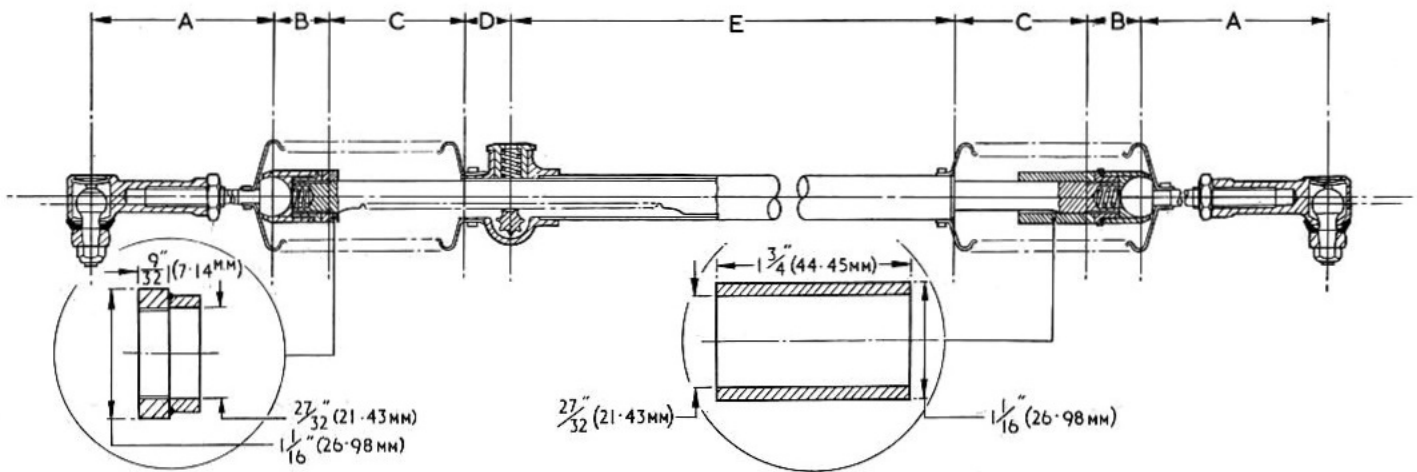

Fig. 15 Rack and pinion unit arrangement drawing

KEY

- | | |
|------------------------|--------------------------|
| A—7.59 in. (192.7 mm.) | D—1.03 in. (26.16 mm.) |
| B—1.34 in. (34.04 mm.) | E—17.03 in. (432.56 mm.) |
| C—3.38 in. (85.85 mm.) | |

11—STEERING COLUMN

Removal

PRELIMINARY NOTE:—Reference is made in the ensuing chapters to components of the steering column assembly. These are itemised and their reference will be found in Fig. 38—Steering and Dash Assembly, section L, page L30 of this manual.

1. Remove bonnet releasing the springs. Disconnect the battery leads.
2. Remove the Nyloc nut and bolt from steering coupling.
3. Note the colours to facilitate assembly and disconnect the steering head cables at their snap connectors.
4. Remove the nuts, washers and bolts then withdraw the outer column lower support clamp, item 46.
5. Remove the nuts and washers and withdraw the lower portion of the outer steering column upper clamp item 49.
6. Withdraw the steering column assembly from the vehicle.

Dismantling

1. Remove the cable trough (tag located to outer column).
2. Prise the horn button assembly from the steering wheel boss, and withdraw the contact plunger assembly.
3. Remove the two retaining screws and switch covers (items 9 and 18).

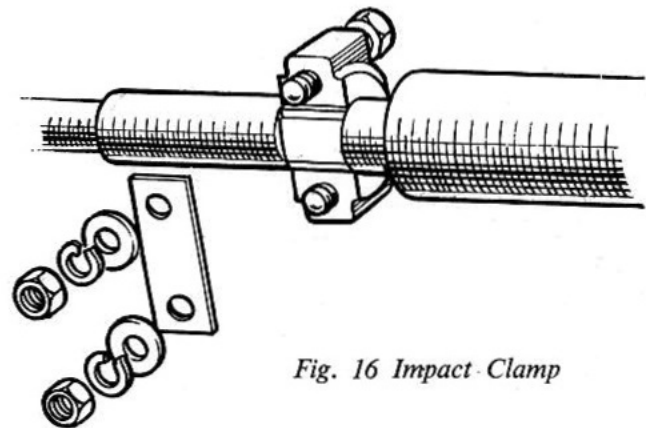

Fig. 16 Impact Clamp

4. Remove the retaining screw and each switch (items 10 and 17).
5. Remove the impact clamp nuts, spring washers, plain washers, spring steel plate, bolts and "U" piece (Fig. 16).
6. Withdraw the lower column from the inner column.
7. Remove the nylon washer from the inner column.
8. Withdraw the steering wheel and inner column from outer column.
9. Remove the nut and utilising a suitable press separate the steering wheel from the inner column.
10. Remove the metal cap from the lower end of the outer column.
11. The bushes can be removed from the outer column by applying an axial load with a long bar whilst depressing the two retaining lugs.
12. Remove the nylon bush, and steel sleeve, from the flexible end of each rubber bush.

NOTE :—One end of the bush has a metal insert.

Assembly

1. Fit the nylon bushes to the steel sleeves and the steel sleeves to the rubber bushes through the flexible ends.
2. Fit the bush assemblies to the outer column so that their locating lugs engage with the holes provided (Fig. 17) and the metal reinforced end of each bush is towards the lower end of the column (Fig. 18).

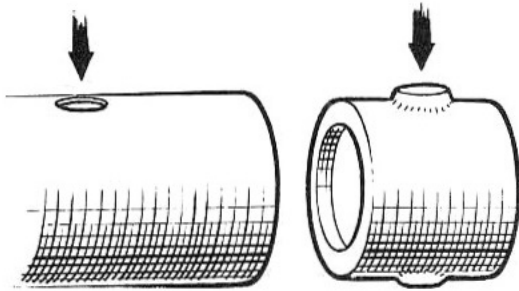

Fig. 17 Arrows indicate outer column bush locations

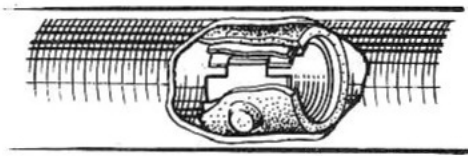

Fig. 18 Cutaway view of an outer column bush

3. Fit the metal cup to the lower end of the outer column.
4. Fit the steering wheel to the inner column and tighten its attachment nut. Peen the metal of the nut to the inner column to prevent its unscrewing.
5. Insert the inner column into the outer column taking care not to dislodge the bushes.
6. Fit the nylon washer to the inner column adjacent to the outer column metal cap.
7. Insert the lower column into the inner column with the machined flat of the former in line with the machined aperture in the latter.
8. Fit the impact clamp "U" piece, bolts, spring steel plate, plain washers, spring washers and Nyloc nuts.
9. Feed the cables of the lamp and direction indicator switches through the aperture in the upper end of the outer column and retain the switches in position by fitting and tightening the attachment screws.
10. Fit the switch covers and fit and tighten the two retaining screws.

11. Insert the horn contact plunger into the steering wheel boss.
12. Fit the horn button assembly. (see fig. 19).
13. Fit the cable trough (tag located to outer column)

Replacement

1. Fit the steering column to the vehicle.
2. Fit the outer steering column upper clamp, retaining washers and nuts. (Leave nuts slack).
3. Fit the outer column lower clamp, and retaining bolts, washer and nuts, arrowed in.
4. With the road wheels and steering wheel in the straight ahead position insert the lower column into the steering coupling, and fit and tighten the retaining bolt and Nyloc nut.
5. Connect the steering head cables at their snap connectors.
6. Position the steering column axially to suit the driver then tighten the outer column upper clamp nuts, lower clamp nuts and impact clamp nuts.
7. Connect battery lead and replace bonnet, re-connecting bonnet springs.

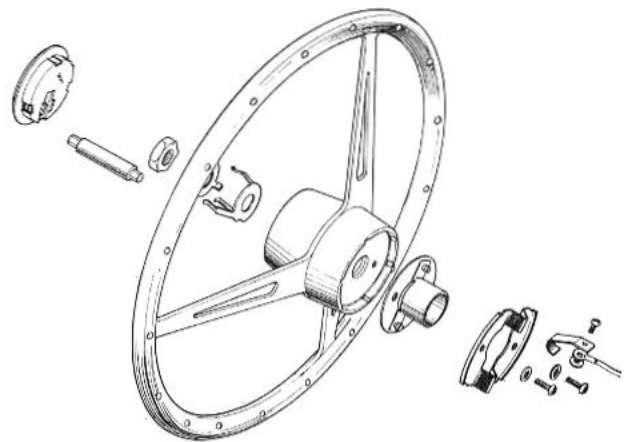

Fig. 19

Steering wheel and horn push assembly

SECTION K**THE BRAKES**

	<i>Chapter</i>
Braking system	<i>Illustration</i>
The braking system components	<i>Key to components</i>
General	1
Maintenance Instructions	2
Lining Pad Replacement	3
Cylinder Maintenance	4
Assembling	5
Brake Pad identification	6
Fitting New Handbrake Pads	7
Handbrake Adjustment	8
Discs	9
Bleeding the Hydraulic System	10
Bleeding Procedure	11
Detecting the Presence of Air	12
The Brake Master Cylinder	13
Dismantling	14
Assembling	15

FILE NOT TO BE REDISTRIBUTED FOR PROFIT ORIGINAL COPYRIGHT HOLDER LOTUS CARS LIMITED 1966

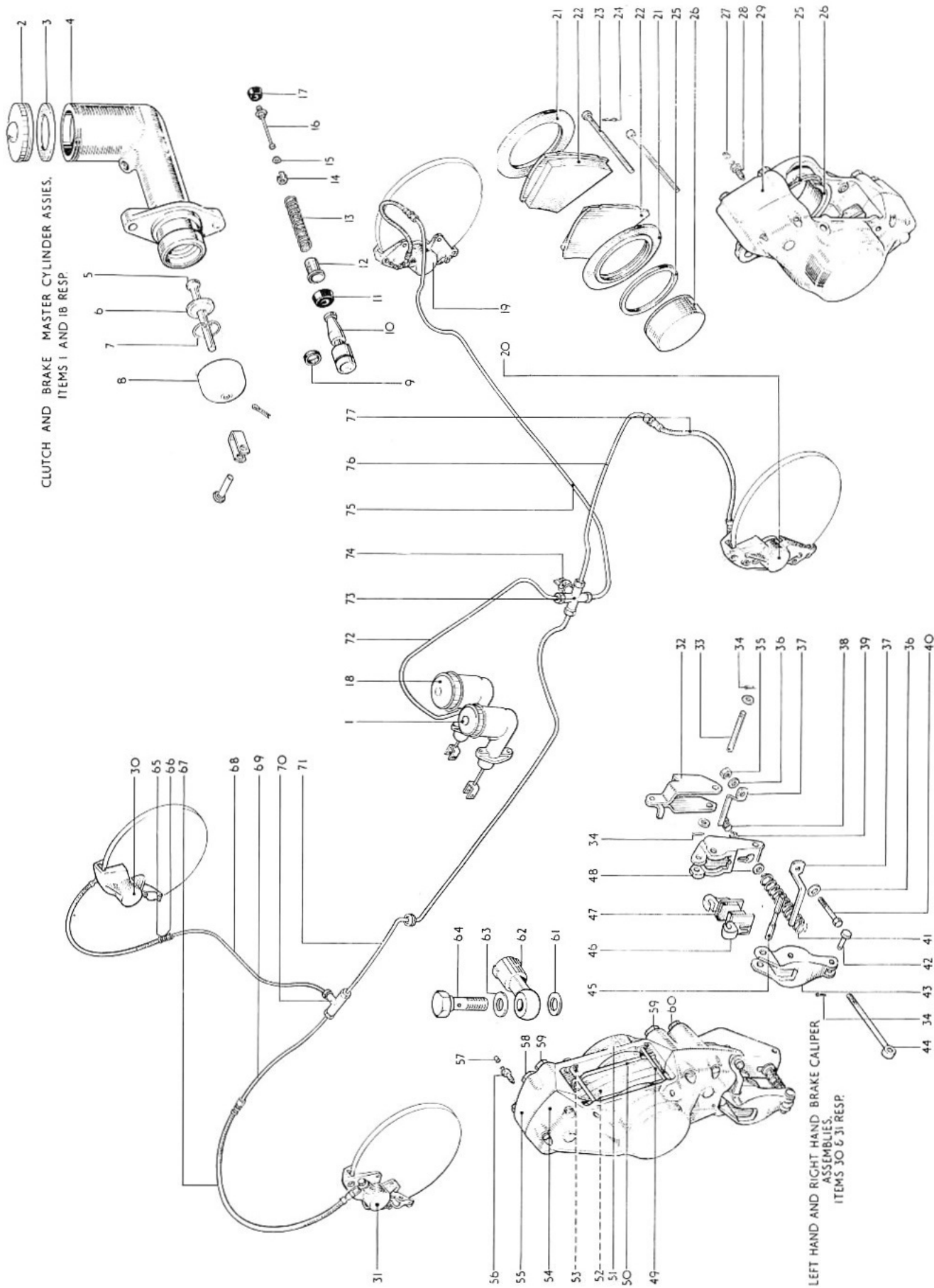

CLUTCH AND BRAKE MASTER CYLINDER ASSIES.
ITEMS 1 AND 18 RESP.

LEFT HAND AND RIGHT HAND BRAKE CALIPER
ASSEMBLIES.
ITEMS 30 & 31 RESP.

LEFT AND RIGHT HAND BRAKE CALIPER ASSEMBLIES.
ITEMS 19 & 20 RESP.

Fig. 1—BRAKING SYSTEM

KEY TO BRAKING SYSTEM COMPONENTS

Key No.	Description	Key No.	Description	Key No.	Description
1	Assy. $\frac{3}{8}$ in. cv. clutch master cyl.	16	Stem	49	Pad retaining pin
2	Cap (brake master cyl. filler)	17	Seal	50	Friction pad assembly (Hydraulically operated)
3	Gasket (brake master cyl. filler cap)	19	Assy. L.H. front brake	51	Rubber boot
4	Cylinder (brake master cyl. assy.)	20	Assy. R.H. front brake	52	Sealing ring (cylinder)
5	Push rod assy. comprising: 5, 6 and 7	21	Dust Seal	53	Piston
6	Retaining washer	22	Pad (friction mat.) assy.	54	Caliper body (outer)
7	Circlip	23	Pad retaining pin (piston assy.)	55	Sealing ring (not illustrated)
8	Dust cover	24	Clip (piston assy.)	56	Sealing ring (inner)
9	End seal	25	Sealing ring (piston assy.)	57	Bleed screw
10	Piston	26	Piston	58	Bleed screw cap
11	Seal	27	Dust cap (bleed screw)	59	Bridge bolt outer
12	Retainer	28	Bleed screw (caliper assy.)	60	Bridge bolt inner
13	Spring	29	Caliper body inner half (illustrated)	61	Bridge bolt outer
14	Spacer		Caliper body outer half (illustrated)	62	Gasket banjo
15	Spring	30	Sealing ring (not illustrated)	63	Banjo
16	Stem	31	Assy. of L.H. rear brake assy.	64	Gasket banjo bolt
17	Seal	32	Assy. of R.H. rear brake assy.	65	Banjo bolt
18	Assy. 75 c.v. int. brake master cyl.	33	Operating lever (handbrake)	66	Lockwasher
2	Cap (clutch master cyl. filler)	34	Pivot pin (operating lever)	67	Locknut
3	Gasket (clutch master cyl. filler cap)	35	Split pin	68	Assy. high pressure hose—rear
4	Cylinder (clutch master cyl. assy.)	36	Nut	69	3 way to L.H.R. 29 in.
5	Push rod assy. comprising: 5, 6 and 7	37	Washer	70	3 way to R.H.R. H 11 in.
6	Retaining washer	38	Lining pad retaining finger	71	Threeway
7	Circlip	39	Adjuster nut	72	5 way to 3 way 76 in.
8	Dust cover	40	Locking spring		Cable clip (latching) spire—
9	End seal	41	Bolt		brake Bundy to chassis
10	Piston	42	Lever return spring	73	Master cylinder to 5 way 17 in.
11	Seal	43	Pivot pin tie bar	74	Five way
12	Retainer	44	Clamping lever outer		Stop light switch
13	Spring	45	Tie rod		Gasket
14	Spacer	46	Handbrake pivot pin	75	5 way to L.H.F. hose 37 in.
15	Spring	47	Friction pad assembly (handbrake)	76	5 way to R.H.F. hose 10 in.
		48	Friction pad assembly (handbrake)	77	Assy. high pressure hose front
			Clamping lever inner		

1—GENERAL.

All four brakes are Girling Disc Brakes and are operated hydraulically by a master cylinder connected directly to the foot pedal via a cross shaft. The two rear brakes, which are mounted on the inside of each suspension wheel bearing housing are fitted with a handbrake mechanism manually operated.

The handbrake mechanism incorporates additional pads and levers connected via push/pull rods to a chassis mounted fulcrum. This fulcrum is in turn actuated from the handbrake lever by a single cable.

The clutch is also hydraulically operated by a slave cylinder bolted to the clutch housing, which is connected by a pipe to a master cylinder linked to the clutch pedal. The supply tank for the braking system is cast integrally with the master cylinder. The reservoir of fluid should be maintained to the level on the outside of the casting.

The brakes on the front wheels and the main rear brakes are self-compensating for wear and no manual adjustment is needed, but regular inspection is required to ensure that the linings are not worn too thin. The rate of wear can be judged by the thickness of the linings as seen in the caliper "window" and the frequency of future inspection can be estimated.

2—MAINTENANCE INSTRUCTIONS.

The pads should be replaced when the lining is worn within $\frac{1}{8}$ in. thick and under no circumstances should it be allowed to wear below $\frac{1}{16}$ in. in thickness. The handbrake pads are not self-adjusting and the movement of the handbrake lever is an indication when adjustment should be made.

The position of handbrake cable adjusters are shown on the brake layout diagram (Fig. 1) and they should be adjusted so that there is not more than .003 between the disc and each pad with the brake lever in the "off" position.

Regular inspection of the Brake Supply Tank is needed so that the level of fluid can be maintained to the mark indicated on the outside of the casting. As the brake pads wear the pistons in the cylinder follow up and fluid from the supply tank is drawn into the system. The cylinders are of a large capacity and the fluid level could fall dangerously low if the precaution of topping up was neglected. The fluid that should be used is Castrol/Girling Brake and Clutch Fluid, Crimson.

3—LINING PAD REPLACEMENT.**Front Brakes**

Jack up the front of the car taking care to chock the rear wheels. Remove nave plates and front road wheels. Remove the wire clips from the two pad retaining pins and withdraw the pins. It is suggested that each worn pad be removed and replaced at a time. Apply slight pressure to each pad before removing to force the piston into the caliper cylinder. This enables the new thicker pad to be inserted more easily. Carry out this

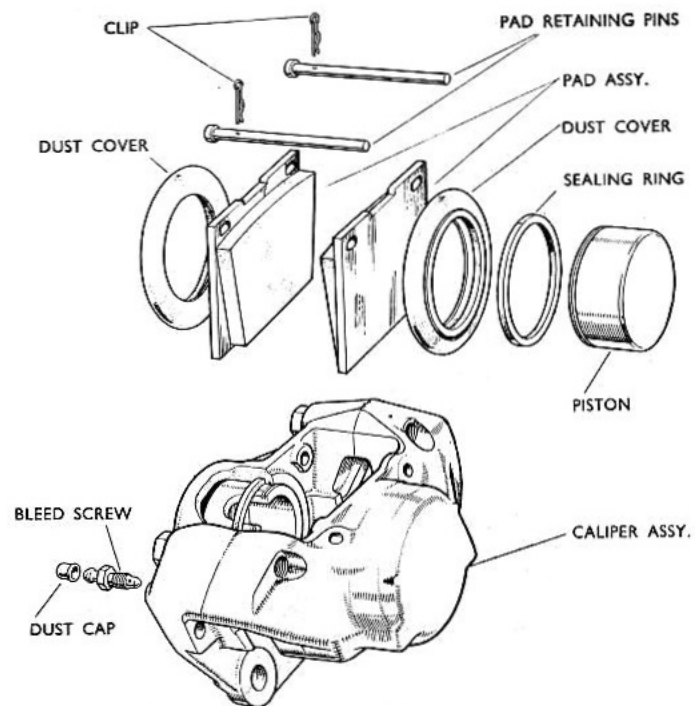

Fig. 2 The Front Caliper Components

operation on all four front pads, taking care to replace retaining pins and clips. It is also suggested incidentally that before each new pad is inserted any road dirt deposited in the pad slot be scraped away and cleaned to ensure a free movement.

Immediately the new pads are fitted, and before the car is driven depress the foot pedal several times with the foot until a soft resistance is felt. This ensures that the pistons are against the pads in the correct operating position.

Rear Brakes

Pad replacement on the rear brakes is effected in a similar manner to those of the front brakes. It should be noted to avoid any confusion over pad replacement the retaining pins do not pass through the pad plates on the rear calipers.

4—CYLINDER MAINTENANCE.

The caliper is made in two paired halves bolted together, with the cylinder bores machined prior to assembly from the jointing faces of each half. The inner half of each caliper has an inlet port for the hydraulic fluid and bleed screw. Fluid passes to the cylinder in the outer half of the caliper via a drilling which is sealed at the joint face by rubber 'O' rings. The two pistons are mounted in the caliper assembly with their crowns facing outwards away from the centre of the caliper, and are each sealed by a piston sealing ring. A dust cover in the form of a bellows is mounted between each piston and the caliper body. Under no circumstances must the four bolts that clamp the two paired halves of each caliper assembly be removed.

To replace the rubber sealing rings or dust covers it is necessary to remove the caliper assembly from the vehicle. Drain the fluid from the system by removing the rubber dust cap, opening the bleed valve and attaching a suitable pipe from the valve to a container, then pump the foot pedal. Disconnect the pipe from the hose and the hose from the bracket, remove the two caliper fixing bolts and lift the caliper, with the hose attached, from the mounting. Take note of shims between the mounting face of the caliper lugs and the bracket, if any are fitted, so that they can be replaced in exactly the same way when refitting.

The brake pads should be removed in the manner described, and instead of pushing the pistons to the bottom of the cylinders, withdraw them from the caliper body, taking care not to damage the surfaces. The dust sealing rings may be removed taking care not to damage the locating grooves. Examine the bores and pistons carefully for any signs of abrasion or scuffing.

It is important that in cleaning the components no petrol, paraffin, trichlorethylene, or mineral fluid of any kind should be used. Clean with methylated spirits, allow to vaporise leaving the components clean and dry.

After cleaning and examining, lubricate the working surfaces of the bores and pistons with clean genuine Girling Crimson Brake and Clutch Fluid.

5—ASSEMBLING.

Fit new rubber seals into the grooves of each cylinder bore. Locate the rubber dust cover with the projecting lip in the groove provided, the outer one, in the cylinder bore.

Insert the piston, closed end first, into the bore taking great care not to damage the polished surface. Push the piston right home to engage the outer lip of the rubber boot in the groove.

The replacement of the lining pads as described will retain the pistons in position.

Refit the caliper assembly to the support bracket by means of the two securing bolts, confirming that the disc passes between the two pads. If packing shims are assembled between the caliper and the mounting face it is important to replace them as initially assembled. Reconnect the hose and bleed the brakes.

6—BRAKE PAD IDENTIFICATION

Front brake pad assembly

Pad Type	Colour Coding	Part No.
D.A.4	Two blue spots	Girling 64325708 FK
	Two yellow spots	

Rear brake pad assembly

Pad Type	Colour Coding	Part No.
DS5S	Three blue spots	Girling 64325418 DT

on no account must any other type of pads be used in either the front or rear positions.

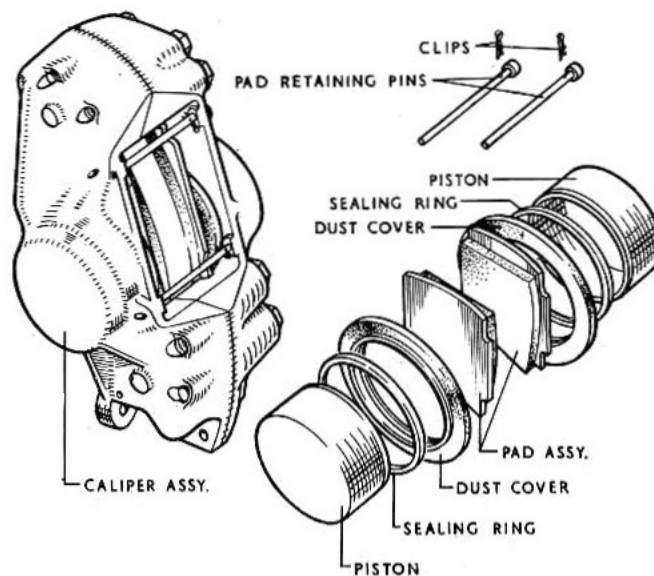

Fig. 3 The Rear Caliper Components

Service Notes

The reservoir level should be checked every 1,500 miles and topped up to the appropriate mark if necessary.

The brake pads should be checked at regular intervals to ensure that even wear has taken place and the pads replaced if they are worn to within $\frac{1}{8}$ in. thickness. Under no circumstances should they be allowed to wear below this thickness. The handbrake pads are not self-adjusting and the movement of the handbrake lever is an indication when adjustment should be made.

Bolt Tightening Torques:

Brake Caliper Mounting Bracket	...	40-45 lb. ft. (5.53 to 6.22 kgm.)
Front Brake Disc to Hub	...	30-34 lb. ft. (4.15 to 4.70 kgm.)
Caliper Piston Dia.	...	1.892 in. (48.05 cm.)

7—FITTING NEW HANDBRAKE PADS

Jack the rear of the vehicle after chocking the front wheels. Remove rear nave plate and rear wheels.

Unscrew the adjustment nut on the handbrake lever clamping bolt taking care to remove the spring locking clip. Unscrew the nut and remove the spring washer from the bolt that passes through the handbrake pad retaining fingers. Withdraw the bolt and the two retaining fingers. Swing the lever outwards away from the disc as far as it will go, and unhook the worn pads by pulling horizontally away from the lever pivot pins in the caliper body. On the inboard handbrake pads it may be necessary to pull on the handbrake actuation rods. To facilitate this operation clean all parts and apply Girling White Brake Grease where necessary.

Place the new pads in position and reassemble in the reverse order to dismantle.

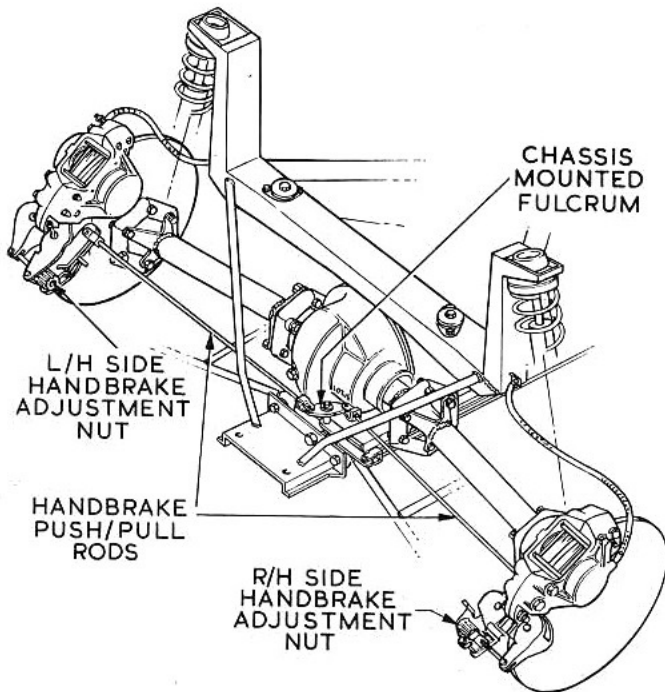

Fig. 4 Handbrake Mechanism

8—HANDBRAKE ADJUSTMENT

Make sure that handbrake is fully off and adjust each handbrake caliper so that there is $\cdot003$ in. between each pad and the disc face. The handbrake adjustment nuts are situated on the inner side of each rear caliper assembly (see fig. 4). A check should be made to ensure that the levers and mechanism are free from dirt and actuate smoothly.

If it should be necessary to remove the levers from the caliper casting the lever pivot pins have to be removed. These are pressed into the casting and it should be noted that the ends of both pins are drilled and tapped 2B.A. to facilitate their removal.

In the event of there being excessive movement in the handbrake lever, adjustment can be made by the cable adjuster. This is situated on the left-hand side of the chassis/gearbox mounting on earlier models and on the right-hand side engine mounting in the case of subsequent models. Slacken the locknut and screw adjuster anti-clockwise until the desired movement of the lever is achieved. Tighten the locknut on completion.

9—DISCS

To ensure that the brake functions at maximum efficiency a check should be made to see that the disc runs perfectly true between the pads. The maximum run-out permissible on the disc is $\cdot004$ in. If excessive run-out is present it will cause knocking back of the pistons which may create judder and excessive pedal travel. If there is any doubt concerning this condition the disc should be replaced.

10—BLEEDING THE HYDRAULIC SYSTEM

The process of removing air from the pipe and cylinders is known as "bleeding" and is necessary whenever any part of the system has been disconnected, or the level of fluid in the supply tank has been allowed to fall so low that air has been drawn into the master cylinder.

When the seals are worn it is possible for air to enter the wheel cylinders without any sign of leaking fluid, and cause a spongy pedal, which is the usual indication of bubbles of air in the system.

It is vital that absolute cleanliness is maintained throughout the entire bleeding operation. Never use a rag of linty texture and ensure that no dirt or grit enters the system—especially at the supply tank. All equipment to be used must be entirely free from petrol, paraffin, or any form of mineral oil, as mineral contamination spreads rapidly in the hydraulic system, causing a dangerous deterioration of the rubber seals. Always replace the rubber cap on each bleed screw to prevent dirt entering the bleed tube during subsequent bleeding operation.

Pressure bleeding methods are not suitable for Girling Systems and are not recommended. For pressure bleeding to be successful it must be accompanied by manual bleeding.

11—BLEEDING PROCEDURE.

Release the parking brake. As the brake bleed nipples face outwards on the rear calipers, bleeding is facilitated by the removal of the rear wheels. Remove the rubber cap from the bleed screw farthest from the master cylinder (i.e. rear, nearside) fit the bleed tube over the bleed nipple, and immerse the free end of the tube in a clean jar containing a little Girling Brake fluid. Unscrew the bleed nipple about three-quarters of a turn and commence bleeding with a fairly fast full stroke of the pedal. (The floor mat should be removed if it prevents this complete movement).

As a C.V. master cylinder is fitted to this system the pedal should be allowed to fly back freely.

One or two slightly faster applications may now be made to advantage. Repeat this procedure until it is apparent that all air has been excluded closing the screw during the last (slow) pedal application.

Repeat with each wheel cylinder in turn, finishing with the cylinder situated nearest the master cylinder (offside front).

It is essential to ensure that at no time during the bleeding operation shall the fluid reservoir level be allowed to fall to a point where air may be admitted.

If the bleeding of any cylinder continues without success for a considerable time it may be that air is being drawn in past the bleed screw threads. In these instances the bleed screw should be tightened at the end of each downward stroke of the pedal and allowing the pedal to return fully before re-opening. Close the bleed screw finally during the last pedal application.

Never use fluid which has just been bled from the system for topping up the supply tank. This fluid will almost certainly be aerated and should be allowed to stand for at least twenty-four hours before re-use.

12—DETECTING THE PRESENCE OF AIR

For all practical considerations the fluid in the hydraulic system is incompressible and the movement of the master cylinder plunger is transmitted without loss to the wheel or slave cylinders. If the air enters the system, part of the plunger movement will be used in compressing the air and causes the "spongy" feel to the pedal movement. This sponginess can be detected more easily by hand pressure than by foot and indicates that "bleeding" is necessary. A more certain test can be applied by the following procedure:

Jack up the car, chock the wheels, release the parking brake. Slowly apply the foot pedal by hand, whilst an assistant rotates one of the wheels. When the pedal has travelled approximately $1\frac{1}{4}$ in. drag should be felt and the next $\frac{1}{2}$ in. to $\frac{3}{8}$ in. of pedal travel should lock the wheel. It is an increase in this distance of travel between the drag and lock which indicates the existence of air, due to its compressibility.

13—THE BRAKE MASTER CYLINDER

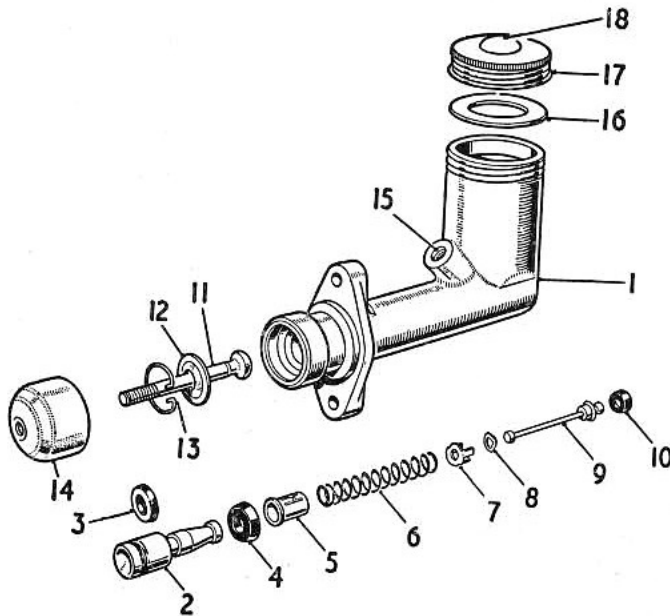

Fig. 5 The Brake Master Cylinder Components

- | | |
|-------------------------|----------------------|
| 1. Master cylinder body | 10. Valve seal |
| 2. Plunger | 11. Push-rod |
| 3. End seal | 12. Retaining washer |
| 4. Plunger seal | 13. Circlip |
| 5. Spring thimble | 14. Dust Cover |
| 6. Spring | 15. Outlet |
| 7. Valve spacer | 16. Cap washer |
| 8. Spring washer | 17. Filler cap |
| 9. Valve stem | 18. Air vent |

The master cylinder is of the centre valve type and has an alloy body with a polished finished bore, and reservoir. The inner assembly is made up of the push rod, dished washer, circlip, plunger seal, spring thimble, plunger return spring, valve spacer, spring washer, valve stem and valve seal. The open end of the cylinder is protected by a rubber dust cover.

14—DISMANTLING

Disconnect the pressure pipe union from the cylinder and remove the securing bolts and clevis pin from jaw end. Remove the filler cap and drain out fluid.

Pull back the rubber dust cover and remove the circlip with a pair of long nosed pliers. The push rod and dished washer can then be removed. When the push rod has been removed the plunger with seal attached will then be exposed. Remove the plunger assembly complete. The assembly can then be separated by lifting the thimble leaf over the shouldered end of the plunger. The seal should be eased off the plunger. Depress the plunger return spring allowing the valve stem to slide through elongated hole of the thimble, thus releasing tension of spring. Remove thimble, spring and valve complete.

Detach valve spacer taking care of the spacer spring washer which is located under the valve head. Remove the seal from the valve head.

Examine all parts, especially the seals, for wear or distortion and replace with new parts where necessary.

15—ASSEMBLING

Replace the valve seal so that the flat side is correctly seated on the valve head. The spring washer should then be located on the under side of valve head, domed side first, being held in position by the valve spacer, the legs of which face towards the valve seal. Replace the plunger return spring centrally on the spacer, insert the thimble into the spring and depress until the valve stem engages through the elongated hole of the thimble making sure the stem is correctly located in the centre of the thimble.

Check that the spring is still central on the spacer. Refit new plunger seal on the plunger with flat of seal seated against the face of the plunger. Insert the reduced end of the plunger into the thimble until the thimble leaf engages under the shoulder of the plunger. Press home thimble leaf.

Smear the assembly well with Girling Brake Fluid, and insert the assembly into the bore of the cylinder valve end first, easing the plunger seal lips in the bore. Replace the push rod with the dished washer under the spherical head into the cylinder followed by the circlip which engages into groove machined in cylinder body.

Replace the rubber dust cover and refit the cylinder to the chassis.

SECTION L

ELECTRICAL SYSTEM

	<i>Chapter</i>
Wiring diagram for Lotus Elan 1600 c.c. (U.K. specification)	<i>Illustration</i>
General description	1
Electrical Components Nos.	2
Battery maintenance	3
Starter motor, model 35G	4
Starter drive "SB" pattern (inboard)	5
The ignition system—General description	6
Uneven firing	7
Testing the low tension circuit	8
High tension cables	9
Sparking plugs	10
Contact breaker mechanism	11
The 25D distributor	<i>Illustration</i>
The 25D distributor	<i>Key to components</i>
Distributor	12
The 23D distributor	<i>Illustration</i>
The 23D distributor	<i>Key to components</i>
Timing the ignition	13
Generator model C.40-1	
General description	14
Routine maintenance	15
Performance data	16
Servicing	17
Control box model RB.106-2	18
Model 9 H miniature wind-tone horns	
General description	19
Maintenance	20
Adjustment	21
Model LA 12 ignition coil	22
Model 2 ST. solenoid	23
Model 4 FJ fuse unit	24
Windscreen wiper model DR3A	
General description	25
Maintenance	26
Data	27
Servicing	28
Lamp Units	
Headlamps	29
L691/L692 front direction indicator lamps	30
L 658 front side lamps	31
L 538/539 rear direction indicator lamps	32
L 551 stop/tail lamp unit	33
Rear number illuminating lamps	34
Interior and instrument lighting	35
Instrument lights	36
Steering and dash assembly	<i>Illustration.</i>
Steering and dash assembly	<i>Key to components</i>
Side and rear lights	<i>Illustration</i>

FILE NOT TO BE REDISTRIBUTED FOR PROFIT ORIGINAL COPYRIGHT HOLDER LOTUS CARS LIMITED 1966

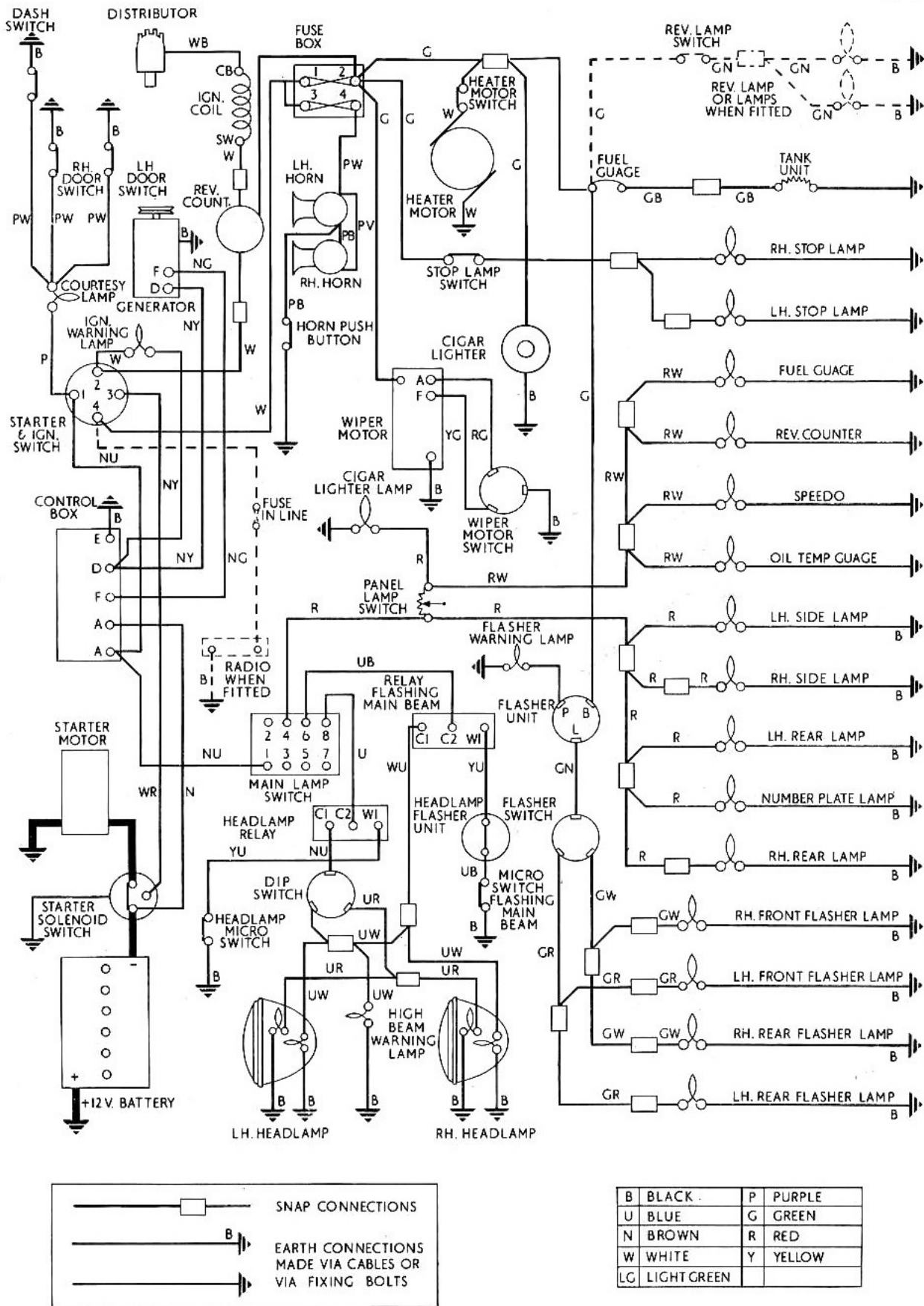

WIRING DIAGRAM FOR LOTUS ELAN 1600 cc. (U.K. SPECIFICATION)

1—GENERAL DESCRIPTION

The 12-volt electrical equipment incorporates compensated voltage control for the charging circuit. The positive earth system of wiring is employed.

The dynamo is mounted on the left of the cylinder block and driven by endless belt from the crankshaft pulley. A rotatable mounting enables the belt tension to be adjusted.

The voltage control unit adjustment is sealed and should not normally require attention. The fuses are carried in external holders mounted in an accessible position on the engine bulkhead together with spare fuses.

The starter motor is mounted on the flywheel housing on the right-hand side of the engine unit and operates on the flywheel through the usual sliding pinion device.

The retractable headlamps employ the double-filament dipping system. Both lamps are fitted with double-filament sealed beam lens units, both dipping either vertically or to the left according to the regulations existing in the country concerned.

2—ELECTRICAL COMPONENT Nos.

Below are listed the main components with their respective part numbers.

	Lucas	Lotus/Ford
Battery (12v 57 amp. FRV9A)		
Generator C.40		109E 10001
*Distributor (special Lucas) 23D4 or 25D4		A26M 009
Starter Motor (M35G)		105E 11001C
Ignition Coil	LA.1245111	
Fuse Unit	4FJ54038033	
Flasher Unit	Magnatex	
Direction Flasher	Magnatex or Clear Hooters R.124/14	
Relay	Magnatex or Clear Hooters R.246	
Flasher Lamp L691	L69153956	
Rear Flasher L539	L53952462	
Stop/tail lamp L551	L69253955	
Horn high note	9H54868008 or Clear Hooters F.725/N.	
Horn low note	9H54868009 or Clear Hooters F.725/N.	
Control Box	RB10637290E	
Starter Solenoid	2ST76464 E	
Dipper Switch (U.S.A. only)	103SA34536B	
Main Dipper	71SA34403	
Flasher Switch	CC933610	
*Rotor Arm	54412165	
Lighting Switch	55A31788D	
Wiper Switch	89SA34325H	
Panel Light Switch	4R78416A	
Interior Light Switch	65SA31851B	
Heater Switch	65SA31851B	

Windscreen Wiper DR3A	54071260
Windscreen Wiper Wheel Box	727764
Side Lamps L658	52599
Headlamp F700 MKX RHD (GB)	58683
Headlamp F700 MKX (U.S.A. & Can.)	59187
Headlamp F700 MKVI (Europe)	58685
Headlamp F700 MKVI (France)	58686
Headlamp F700 MKVI (LHD).	58687
Headlamp F700 MKVI (Sweden)	58688

3—BATTERY MAINTENANCE

In order to keep the battery in good condition a periodical inspection must be made: the cell specific gravity should be checked and the electrolyte should be topped up if necessary.

Topping Up

Remove the filler plug from each cell and examine the level of the electrolyte. Add distilled water as required to bring the level of the electrolyte in each cell just above the separators.

NOTE.—Do not use tap-water and do not use a naked light when examining the condition of the cells. Wipe away all dirt and moisture from the top of the battery.

Testing the Condition of the Battery.

Every 1,000 miles (1600 Km.) examine the condition of the battery by taking hydrometer readings. There is no better way of ascertaining the state of charge of a battery.

The hydrometer contains a graduated float on which is indicated the specific gravity of the acid in the cell from which the same is taken.

The specific gravity readings and their indications are as follows:

Climates normally below 90°F. (32°C.)

1.270 to 1.290	Cell fully charged.
1.190 to 1.210	Cell about half-discharged.
1.110 to 1.130	Cell completely discharged.

Climates frequently above 90°F. (32°C.)

1.210 to 1.230	Cell fully charged.
1.130 to 1.150	Cell about half-discharged.
1.050 to 1.070	Cell completely discharged.

These figures are given assuming an electrolyte temperature of 60°F. (16°C.) If the temperature of the electrolyte exceeds this .002 must be added to hydrometer readings for each 5°F. rise to give the true specific gravity. Similarly .002 must be subtracted from hydrometer readings for every 5°F. below 60°F.

The readings of all the cells should be approximately the same. If one cell gives a reading very different from the rest it may be that the electrolyte has been spilled or has leaked from the cell or there may be an internal fault. In this case it is advisable to have the battery examined by a battery specialist. Should a battery be in a low state of charge, it should be recharged by taking the car for a long daytime run or by charging from an external source of D.C. supply at a current rate of 4 amps. (5 amps. for nine-plate batteries) until the cells are gassing freely.

After examining the battery check the vent plugs, making sure that the air passages are clear, and screw the plugs into position. Wipe the top of the battery to remove all dirt and moisture.

Storage

If a battery is to be out of use for any length of time it should first be fully charged and then given a freshening charge about every fortnight.

A battery must never be allowed to remain in a discharged condition as this will cause the plates to become sulphated.

Initial Filling and Charging

The specific gravity of the electrolyte necessary to fill a new battery which has been supplied dry and uncharged and the specific gravity at the end of the charge are as follows:

Climate	S.G. of filling acid (corrected to 60°F. (16°C.))	S.G. at end of charge
Normally below 90°F. (32°C.)	1.270	1.270 to 1.290
Normally over 90°F. (32°C.)	1.210	1.210 to 1.230

The electrolyte is prepared by mixing distilled water and concentrated sulphuric acid 1.835 S.G. The mixing must be carried out in a lead-lined tank or a suitable glass or earthenware vessel. Steel or iron containers must NOT be used. The acid must be added slowly to the water while the mixture is stirred with a glass rod. NEVER ADD THE WATER TO THE ACID, as the severity of the resulting chemical reaction may give dangerous consequences.

Heat is produced by the mixture of acid and water, and electrolyte should, therefore, be allowed to cool before it is poured into the battery, otherwise the plates, separators, and moulded container may be damaged.

The temperature of the filling-in acid, battery and charging room should be above 32°F. (0°C.)

To produce electrolyte of the correct specific gravity:	Add 1 part by volume of
To obtain specific gravity (corrected to 60°F. (16°C.))	1.835 S.G. acid to distilled water by volume as below
1.270	2.8 „
1.210	4 „

Carefully break the seals in the filling holes and half-fill each cell in the battery with dilute sulphuric acid solution of the appropriate specific gravity (according to tem-

perature) (see table). The quantity of electrolyte required to half-fill a two-volt cell is $\frac{2}{8}$ pint (.215 litre) or $\frac{1}{2}$ pint (2.8 litre) for nine-plate batteries. Allow to stand for at least six hours, then complete the filling of the cells by the addition of more diluted acid of the same specific gravity as before until the level reaches the bottom of the filling holes, and allow the battery to stand for at least another two hours before commencing the first charge.

Charge at a constant current of 2.5 amps. (3.5 amps. for nine-plate batteries) until the voltage and temperature-corrected specific gravity readings show no increase over five successive hourly readings. This period is dependent upon the length of time the battery has been stored since manufacture, and will be from 40 to 80 hours, but usually not more than 60.

Throughout the charge the acid must be kept level with the tops of the separators in each cell by the addition of acid solution of the same specific gravity as the original filling-in acid.

If, during charge, the temperature of the acid in any cell of the battery reaches the maximum permissible temperature (for climates normally below 90°F. (32°C.) the maximum permissible temperature is 100°F. (37.7°C.) whilst for climates frequently above 90°F. (32°C.), the maximum permissible temperature is 120°F. (48.8°C.), the charge must be interrupted and the battery temperature allowed to fall at least 10°F. (5.5°C.) before charging is resumed.

At the end of the first charge, i.e. when specific gravity and voltage measurements remain substantially constant, carefully check the specific gravity in each cell to ensure that it lies within the limits specified. If any cell requires adjustment the electrolyte above the plates must be siphoned off and replaced either with acid of the strength used for the original filling in, or distilled water, according to whether the specific gravity is too low or too high respectively. After such adjustment the gassing charge should be continued for one or two hours to ensure adequate mixing of the electrolyte. Re-check if necessary, repeating the procedure until the desired result is obtained

4—STARTING MOTOR MODEL 35G

General

SERIES-PARALLEL

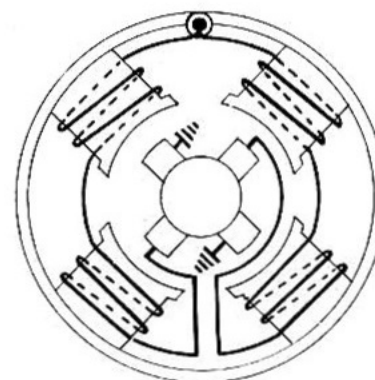

Fig. 3. Internal connections (series-parallel) of the starting motor.

This electric starting motor is a four-pole four-brush machine having an extended shaft which carries the engine engagement gear, or starter drive as it is more usually named. The diameter of the yoke is $3\frac{1}{2}$ inches.

The starting motor is of similar construction to the generator except that heavier gauge conductors are used in the construction of the armature and field coils. The field coils—which are formed from aluminium strip—are parallel-connected between the field terminal and the insulated pair of brushes.

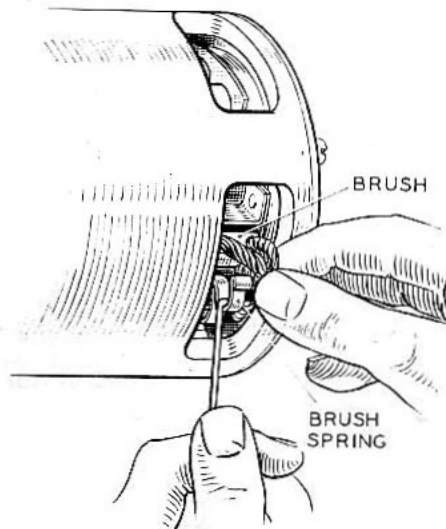

Fig. 4. Checking brushes

Routine Maintenance

About every 12,000 miles take the cover band off the starting motor and carry out the following procedure:

- (a) Check that the brushes move freely in their holders by holding back the brush springs and pulling gently on the flexible connectors. If movement is sluggish, remove the brush from its holder and clean its sides with a fluffless petrol-moistened cloth.

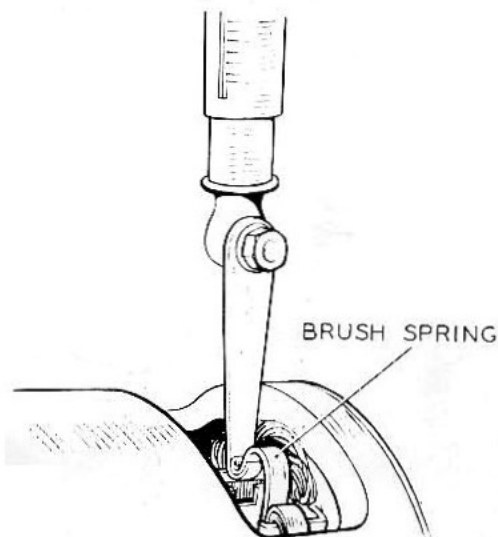

Fig. 5. Checking brush spring tension

Replace the brush in its original position. Brushes which are worn to less than $\frac{5}{16}$ -in. in length must be renewed.

- (b) Check the tension of the brush springs using a spring scale. The correct tension is 30–34 oz. New springs must be fitted if tension is low.
- (c) The commutator must be clean and have a polished appearance. If necessary, clean it by pressing a fine dry cloth against it while the starter is turned by applying a spanner to the squared extension of the shaft. Access to the squared shaft is gained by removing the thimble-shaped metal cover. If the commutator is very dirty, moisten the cloth with petrol.
- (d) Keep all electrical connections clean and tight. Any which may have become dirty must be cleaned and the contacting surfaces lightly smeared with petroleum jelly.

Performance Data

Lock Torque:	7.7 lb.-ft. with 330–350 amp. at 7.5–7.1 volts.
Torque at 1,000 r.p.m.:	4.5 lb.-ft. with 215–235 amp. at 9.1–8.7 volts.
Light running current:	45 amps. at 9,500–11,000 r.p.m.

Servicing

- (a) *Testing in Position.*

If the starting motor does not operate or fails to crank the engine when the starting button is used, switch on the lamps (or connect a moving-coil 0–20 voltmeter between the battery terminals) and again use the starting button.

- (i) The lamps dim (or the voltmeter reading falls appreciably) but the motor does not crank the engine.

This may be caused by the starter drive pinion being jammed in mesh with the engine flywheel. The pinion can usually be freed by removing the cap and applying a spanner to the squared extension of the shaft at the commutator end. It is advisable to remove the starting motor from the engine and inspect the starter drive as described in para. 4 (e).

Sluggish action of the starting motor may be due to a discharged battery. Check by disconnecting the existing cables and reconnecting the motor to a battery known to be fully charged. If the starting motor now gives the normal cranking of the engine, the vehicle battery must be examined.

If the starting motor still does not operate satisfactorily, it must be removed from the engine and the starting motor and starter drive examined, see para. 4 (b).

- (ii) The lamps do not dim (or the voltmeter reading remains unaffected) and the motor does not crank the engine.

Check by means of a voltmeter or battery-

voltage test lamp that the circuit up to the supply terminal on the motor is in order.

If no voltage is indicated (or the test lamp does not light), check the circuit from battery to motor via the starter switch. Ensure that all connections are clean and tight. If the switch is found to be faulty, a replacement must be fitted. A reading of battery voltage (or the test lamp lighting with full brilliance) at the supply terminal indicates that the starting motor has an internal fault and must be removed from the engine for examination.

If the motor operates but does not crank the engine, the starter drive is in need of cleaning or may have developed some other fault. In either event the motor must be removed from the engine.

(b) *Bench Testing.*

(i) Removing the starting motor from the engine: Disconnect the earth terminal on the battery to avoid any danger of short circuits. Remove the heavy cable from the starting motor.

Remove the mounting bolts and withdraw the starting motor from the engine.

(ii) Measuring the light running current:

Secure the starting motor in a vice. Connect the starting motor in a series with a starter switch, an ammeter capable of carrying 600 amperes and an appropriate voltage supply. Use cables of similar size to those in the vehicle starting motor circuit. A fixing lug on the drive end bracket is a suitable earthing point on the starting motor. Connect a voltmeter between the terminal and yoke.

Operate the switch and check the speed of armature rotation, using a tachometer, and the reading given by the ammeter. The speed should be 9,500—11,000 r.p.m., and the

current 45 amp. (approx.).

While the starter motor is running at speed, examine the brushgear and commutator for undue sparking or excessive brush movement.

(iii) Measuring lock torque and lock current:

With the starting motor firmly clamped in the vice, attach an arm to the driving pinion, see Fig. 4 for details. Connect the free end of this arm to a spring scale.

Operate the switch and note the current consumption, the voltage and the spring scale reading.

The lock torque of the starting motor, calculated from the spring scale reading, should be 7.7 lb.-ft. with a current of 330—350 amp. and a voltage of 7.5—7.1 volts.

The measure of torque can be calculated by multiplying the reading on the spring scale in pounds by the length of the arm in feet.

(c) *Fault Diagnosis.*

An indication of the nature of a fault or faults may be deduced from the results of the no-load and lock torque tests.

Symptom

Speed, torque and current consumption correct.

Speed, torque and current consumption low.

Speed and torque low, current consumption high.

Probable Fault

Assume motor to be in normal operating conditions.

High resistance in brushgear, e.g. faulty connections, dirty or burned commutator causing bad brush contact.

Tight or worn bearings, bent shaft, insufficient end play, armature fouling a pole shoe, or cracked spigot on drive end bracket.

Short-circuited armature, earthed armature or short-circuited field coils.

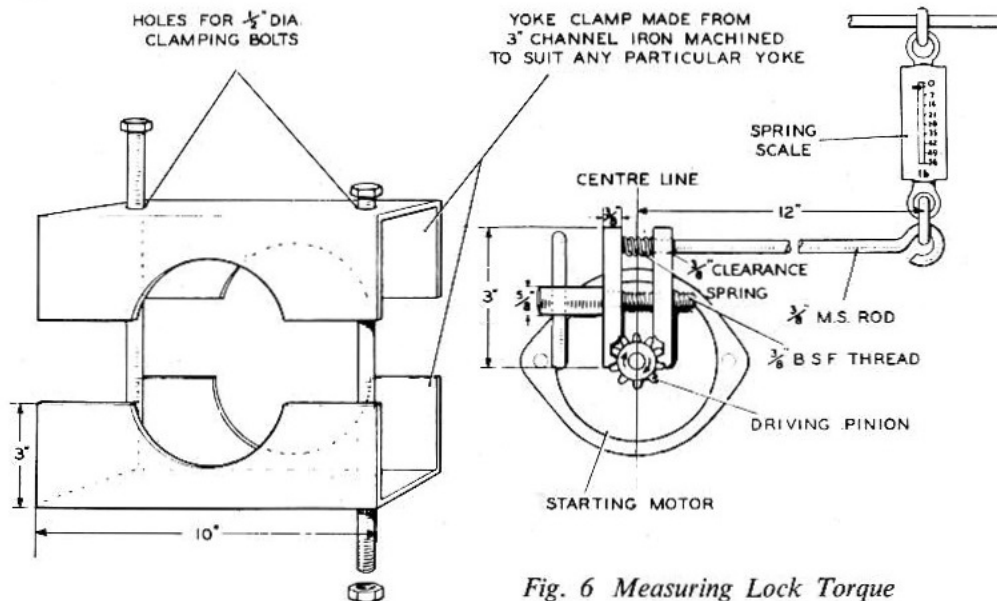

Fig. 6 Measuring Lock Torque

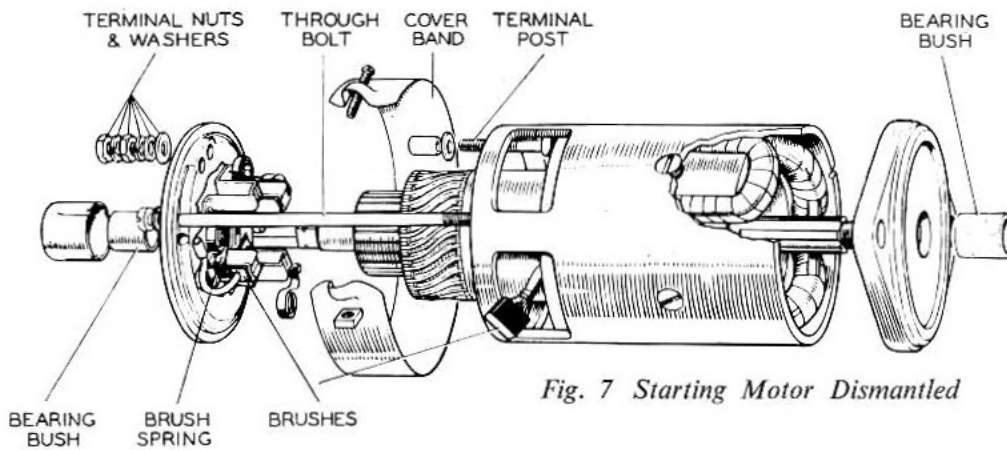

Fig. 7 Starting Motor Dismantled

Speed and current consumption high, torque low.

Armature does not rotate, no current consumption.

Armature does not rotate, high current consumption. Excessive brush movement.

Excessive arcing at the commutator:

If any fault is indicated, the starting motor must be dismantled, and a further check made.

Short-circuited field coils.

Open-circuited armature or field coils. If the commutator is badly burned there may be poor contact between brushes and commutator.

Earthed field winding, armature prevented mechanically from rotating.

Low brush spring tension, worn or out-of-round commutator. "Thrown" or high segments on commutator.

Defective armature windings.

(d) *Dismantling.*

- (i) Remove the cover band, hold back the brush springs and lift the brushes from their holders.
- (ii) Remove the nuts from the terminal post which protrudes from the commutator end bracket.
- (iii) Unscrew the two through bolts from the commutator end bracket and remove the commutator end bracket from the yoke.
- (iv) Remove the driving end bracket with armature and drive from the starting motor yoke.
- (v) If it is necessary to remove the drive end bracket from the armature it can be slid off after the drive has been dismantled.

(e) *Bench Inspection.*

After the starting motor has been dismantled, individual items must be examined as follows:

Brushgear: Where necessary, the brushes and brush-holders must be cleaned using a clean fluffless petrol-moistened cloth.

To prevent damage to the commutator, brushes must be replaced when worn to $\frac{5}{16}$ in. in length.

To replace the brushes, proceed as follows :

Insulated Brushes:

Cut off the original brush flexible $\frac{1}{8}$ in. (3 mm. approx.) from the aluminium.

Clean up and tin the original resistance-brazed joint.

Open out the loop of the replacement brush flexible.

Tin the loop, taking great care not to allow any solder to run towards the brush.

Place the original joint within the loop.

Squeeze up and solder.

NOTE:—Providing the necessary equipment is available for refitting and tightening pole shoes, the above

operations will be found easier to carry out if the field coils are removed from the yoke.

Earth Brushes:

Unsolder the brush flexible from the clip located beneath the brush box mounting. Open up the clip, insert the replacement flexible, squeeze up the clip and re-solder.

The brushes are pre-formed so that bedding to the commutator is unnecessary.

Check the brush spring tension using a spring scale (see para. 2 (b)).

Check the tension of any new spring and ensure that it makes contact with the centre of the brush top.

Commutator:

A commutator in good condition will be smooth and free from pits and burned spots.

Clean the commutator with a petrol-moistened cloth. If this is ineffective, carefully polish with a strip of fine glass-paper, while rotating the armature. To remedy a badly worn commutator, dismantle the starter drive and remove the armature from the end bracket.

Mount the armature in a lathe, rotate at a high speed and take a light cut with a very sharp tool. Do not remove any more metal than is necessary. Finally polish with very fine glass-paper.

The insulators between the commutator segments **MUST NOT BE UNDERCUT.**

Armature:

Check for lifted commutator segments and loose turns in the armature winding. These may be due to the starting motor having remained engaged while the engine is running, thus causing the armature to be rotated at excessive speed. A damaged armature must always be replaced—no attempt should be made to machine the armature core or to true a distorted armature shaft. An indication of a bent shaft or a loose pole shoe may be given by scored armature laminations.

To check armature insulation, use an ohm meter or a 110-volt a.c. test lamp. A high reading should be shown on the meter when connected between the armature shaft and the commutator segments. If

a test lamp is used, it must not light when connected as above. Faulty insulation will be indicated by a low ohmic reading or by lighting of the test lamp. If a short circuit is suspected, check the armature on a "growler". The motor overheating may cause blobs of solder to short circuit the commutator segments. If an armature fault cannot be located and remedied, a replacement must be fitted.

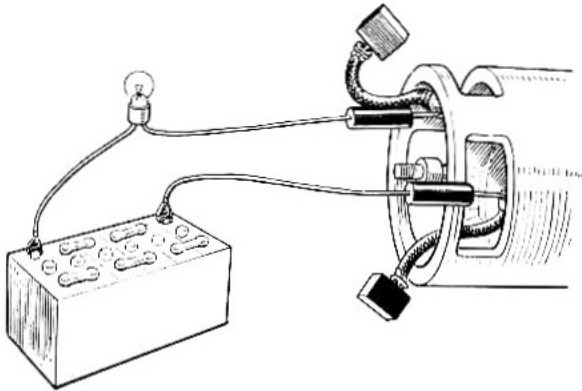

Fig. 8 Testing Field Coils for Continuity

Field Coils:

Continuity Test:

Connect a battery and suitable bulb in series with two pointed probes.

If the lamp fails to light in the following test, an open circuit in the field coils is indicated and unless a yoke assembly is available the starting motor must be replaced.

When the probes are placed on the brush tappings, the bulb should light.

Lighting of the lamp does not necessarily indicate that the field lighting coils are in order. It is possible that a field coil may be earthed to a pole shoe or to the yoke.

Insulation Tests:

Connect an ohm meter or a 110-volt a.c. test lamp between the terminal post and clean part of the yoke. Lighting of the test lamp or a low ohmic reading indicates that the field coils are earthed to the yoke,

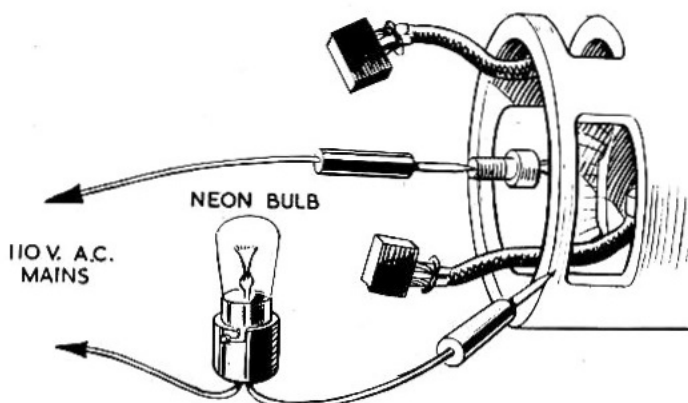

Fig. 9 Testing Field Coil Insulation

and the assembly (or complete unit) must be replaced. Again using the 110-volt test lamp, check the soundness of the insulation on the two insulated brush boxes (see Fig. 8.) Wipe clear from the boxes all dust and dirt before testing in this fashion.

Replacing the Field Coils:

Unscrew the four pole-shoe retaining screws using a wheel-operated screwdriver.

Remove the insulation piece which is fitted to prevent the inter-coil connectors from contacting with the yoke.

Mark the yoke and pole shoes in order that they may be refitted in their original positions.

Draw the pole shoes and coils out of the yoke and lift off the coils.

Fit the new field coils over the pole shoes and place them in position inside the yoke. Ensure that the tapping of the field coils is not trapped between the pole shoes and the yoke.

Locate the pole shoes and field coils by lightly tightening the fixing screws.

Replace the insulation piece between the field coil connections and the yoke.

Finally, tighten the screws by means of the wheel-operated screwdriver.

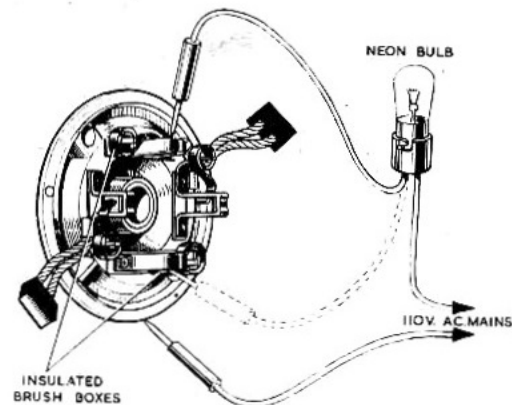

Fig. 10 Testing Brush Box Insulation

Bearings:

Bearings which are worn to such an extent that they will allow excessive side play of the armature shaft must be replaced.

To replace the bearing bushes proceed as follows:

- (i) Press the bearing bush out of the end bracket.
- (ii) Press the new bearing bush into the end bracket using a shouldered, highly polished mandrel of the same diameter as the shaft which is to fit in the bearing. Porous bronze bushes must not be opened out after fitting, or the porosity of the bush may be impaired. Before fitting a new porous bronze bearing bush it should be completely immersed for 24 hours in clean thin engine oil. On occasions of urgency this period may be shortened by heating the oil to 100°C. (212°F.) for two hours, then allowing to cool before removing the bearing bush.

Starter Drive:

The pinion must move freely along the splined sleeve. If there is any dirt or foreign matter on the sleeve, the starter drive must be washed in petrol or paraffin and a light film of machine oil smeared on it.

(f) Reassembling.

This is, in the main, a reversal of the procedure outlined for dismantling the starter.

5—STARTER DRIVE**“SB” PATTERN (Inboard)****General**

The pinion is carried on a barrel type assembly which is mounted on a screwed sleeve. This sleeve is carried on splines on the armature shaft and is arranged so that it can move along the shaft against a compression spring to reduce the shock loading at the moment engagement takes place.

When the starter switch is operated, the armature shaft and screwed sleeve rotate. Owing to the inertia of the barrel assembly, the latter is caused to move along the sleeve until the pinion comes into engagement with the flywheel ring. The starter will then turn the engine. As soon as the engine fires and commences to run under its own power, the flywheel will be driven faster by the engine than the starter. This will cause the barrel assembly to be screwed back along the sleeve, so drawing the pinion out of mesh with the flywheel teeth. In this manner the drive safeguards the starter against damage due to being driven at high speeds.

A pinion restraining spring is incorporated in the drive. This spring prevents the pinion vibrating into mesh when the engine is running.

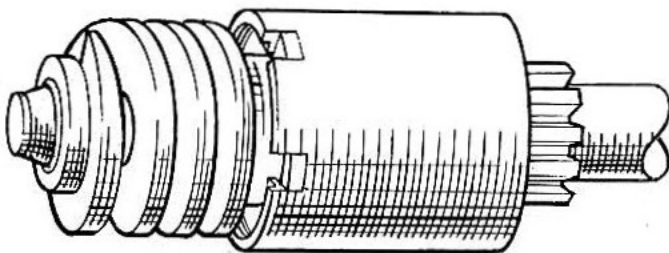

Fig. 11 Drive Assembled

Routine Maintenance

If any difficulty is experienced with the starting motor not meshing correctly with the flywheel, it may be that the drive requires cleaning. The barrel assembly should move freely on the screwed sleeve; if there is any dirt or other foreign matter on the sleeve it must be washed off with paraffin.

In the event of the pinion becoming jammed in mesh with the flywheel, it can usually be freed by turning the starter motor armature by means of a spanner applied to the shaft extension at the commutator end. This is accessible by removing the cap which is a push fit.

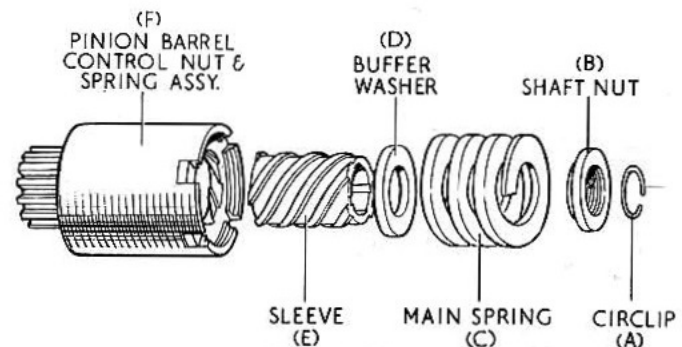

Fig. 12 Drive Dismantled

Dismantling and Reassembly

Having removed the armature as described in the section dealing with starting motors, the drive can be dismantled as follows:

Remove the circlip from the shaft nut at the end of the starter drive by means of a suitable press (see Fig. 11). Hold the squared starter shaft extension at the commutator end by means of a spanner and unscrew the shaft nut (B).

Lift off the main spring (C) drive retaining cap and buffer washer (D) and sleeve (E) will now slide out of the pinion and barrel assembly.

NOTE: The pinion and barrel assembly is permanently retained during manufacture by rolling the four projecting lugs at the trailing edge of the barrel over the four notches of the control nut. This assembly cannot be dismantled for subsequent reassembly. When necessary, the complete barrel assembly (and preferably the screwed sleeve) must be replaced.

The reassembly of the drive is a reversal of the dismantling procedure.

NOTE: Should either the control nut or screwed sleeve be damaged, then a replacement assembly of screwed sleeve and control nut must be fitted. These components must not be renewed individually.

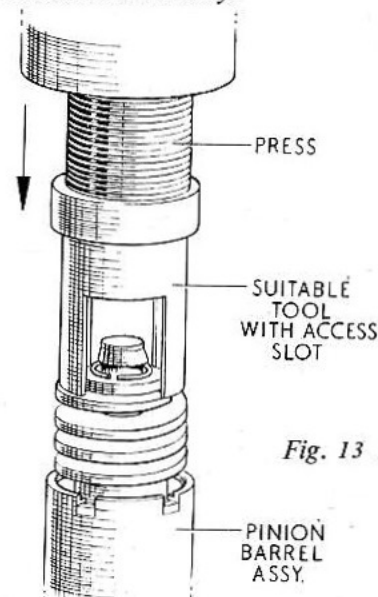

Fig. 13 Dismantling the Drive

THE IGNITION SYSTEM

6—GENERAL DESCRIPTION

The ignition system consists of two circuits—primary and secondary. The primary circuit includes the battery, the ignition switch, the primary or low-tension circuit of the coil, and the distributor contact breaker and capacitor. The secondary circuit includes the secondary or high-tension circuit of the coil, the distributor rotor and cover segments, the high-tension cables, and the sparking plugs.

The ignition coil, which is mounted on the right-hand side of the engine compartment consists of a soft-iron core around which is wound the primary and secondary windings. The coil carries at one end a centre high-tension terminal and two low-tension terminals marked "SW" (switch) and "CB" (contact breaker) respectively.

The ends of the primary winding are connected to the "SW" and "CB" terminals and the secondary winding to the "CB" terminal and the high-tension terminal.

The distributor is mounted on the right-hand side of the engine and is driven by the helical gear on the jackshaft which in turn is chain driven by the crankshaft, control of the distributor is controlled by a centrifugal application. The centrifugal mechanism regulates the ignition advance according to engine speed. The effect of this mechanism is to give added efficiency over the full operating range of the engine.

A keyed moulded rotor with a metal electrode and special centrifugally operated advance characteristics is mounted on top of the cam. This rotor is designed to automatically limit the distributor revolutions to 3,250 per minute, but may operate within a 3,200—3,300 r.p.m. range (6,400—6,600 r.p.m. engine speed). **UNDER NO CIRCUMSTANCES SHOULD THIS ROTOR BE REPLACED BY A STANDARD COMPONENT.** Attached to the distributor body above the centrifugal advance mechanism is a contact breaker plate carrying the contact breaker points and a capacitor connected in parallel. A cover is fitted over the distributor body and retained by two spring clips attached to the body.

Inside the cover is a centre electrode and spring-loaded carbon brush which makes contact with the rotor. The brush is of a composite construction, the top portion being made of a resistive compound, while the lower portion is made of softer carbon to prevent wear of the rotor electrode. Under no circumstances must a short, non-resistive brush be used to replace this long, resistive type. A measure of radio interference suppression is given by this brush.

Spaced circumferentially around the centre electrode are the sparking plug high-tension cable segments. The distributor is secured in position on the cylinder block by a clamp plate.

The sparking plugs are located along the centre line of the engine cylinder head between the cam boxes and have a 14 mm. thread with a $\frac{3}{8}$ in. reach.

When the ignition is switched on, the current from the battery flows through the primary circuit and a magnetic

field is built up around the core of the coil. When the contact breaker points are opened by rotation of the distributor cam the current flow is interrupted, causing a high voltage to be induced in the secondary winding of the coil by the collapse and consequent change in the magnetic field. The high-tension current thus generated in the secondary winding of the coil is conveyed by the coil high-tension cable to the centre terminal of the distributor cover. From here the current passes through the carbon brush to the rotor, where the high-tension current passed along the rotor electrode and is distributed to the segments and thence to the sparking plugs via the high-tension cables.

7—UNEVEN FIRING

To test with sparking plugs in position:

1. Start the engine and set it to run at a fairly fast idling speed.
2. Short-circuit each plug in turn by lifting off each plug lead by means of a pair of insulated handled pliers over each plug cap. No difference in the engine performance will be noted when short-circuiting the plug in the defective cylinder. Shorting the other plugs will make uneven running more pronounced.
3. Having located the cylinder which is at fault, stop the engine and slide the rubber covered plug cap down the cable from the terminal of the sparking plug. Restart the engine and hold the end of the cable about $\frac{3}{16}$ in. (4.8 mm.) from the cylinder head by means of the insulated pliers.
4. If the sparking is strong and regular the fault probably lies in the sparking plug. Remove the plug, clean it, and adjust the gap to the correct setting, or alternatively fit a replacement plug. See chapter 4.
5. If there is no spark, or if it is weak and irregular, examine the cable from the sparking plug to the distributor. If the plastic covered suppressed leads have been bent at any acute angle, or suffered heavy service, the carbon inner electrode may break down, in which case the cable should be renewed. Finally, examine the distributor moulded cap, wipe the inside and outside with a clean dry cloth, see that the carbon brush moves freely in its holder, and examine the moulding closely for signs of breakdown. After long service it may have become tracked, that is, a conducting path may have formed between two or more of the electrodes or between one of the electrodes and some part of the distributor in contact with the cap. Evidence of a tracked cap is shown by the presence of a thin black line in the place indicated. A replacement distributor cap must be fitted in place of one that has become tracked.

8 TESTING THE LOW-TENSION CIRCUIT

Testing in Position

1. Spring back the securing clips on the distributor and remove the moulded cap and rotor. If the rotor is a tight fit it can be levered off carefully with a screw-driver.

2. Check that the contacts are clean and free from pits, burns, oil, or grease. Turn the engine and check that the contacts are opening and closing correctly and that the clearance when the contacts are fully opened is between .014 and .016 in. (.36 and .40 mm.). Correct the gap if necessary.
3. Disconnect the cable at the contact breaker terminal "CB" of the coil and at the low-tension terminal of the distributor and connect a test lamp between these terminals. If the lamp lights when the contacts close and goes out when the contacts open the low-tension circuit is in order.

9—HIGH TENSION CABLES

1. The high-tension cables must be examined carefully and any which have the insulation cracked, perished, or damaged in any way must be replaced.
2. To fit the cable to the terminal of the ignition coil, thread the knurled moulded terminal over the lead, bare the end of the cable for about $\frac{1}{4}$ in. (6 mm.), thread the wire through the brass washer removed from the original cable, and bend back the strands over the washer. Finally, screw into its terminal. To make the connections to the terminals in the distributor moulded cap first remove the cap and slacken the screws on the inside of the moulding till they are clear of the cables. Cut the new cables off to the required length, apply a coating of silicone grease to the cable ends, and push them completely home in the holes in the moulding. Tighten the screws, they will pierce the rubber insulation and make good contact with the cable core.

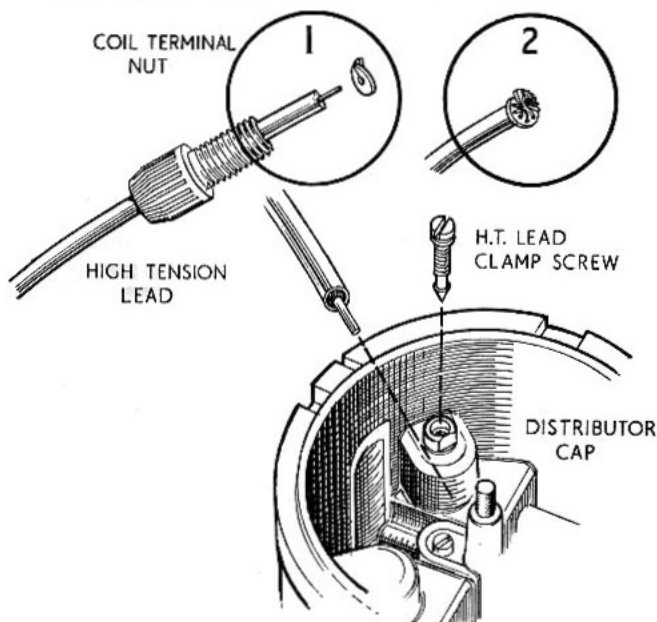

Fig. 14

The correct method of fitting a high-tension cable to the ignition terminal nut.

3. The cables from the distributor to the sparking plugs must be connected up in the correct firing order which is, 1, 3, 4, 2.

A coating of silicone grease should also be applied to the lip of the distributor cap.

4. "Resistive Cable Set" supplied under Lotus part No. 26M706, is supplied in finished lengths, and it is not recommended that these are replaced by any cable other than that specified.

10—SPARKING PLUGS—Autolite AG 32

Service Procedure

To maintain peak sparking plug performance, plugs should be inspected cleaned, and regapped at 3,000 miles (4,800 km.). Under certain fuel and operating conditions, particularly extended slow-speed town driving, sparking plugs may have to be serviced at shorter intervals.

Disconnect the ignition cables from all sparking plugs. Remove the sparking plugs using the correct size deep socket wrench and place them in a suitable holder, preferably in the order they were in the engine.

Analysing Service Conditions

Examine the gaskets to see if the sparking plugs were properly installed. If the gaskets were excessively compressed, installed on dirty seats, or distorted, leakage has probably occurred during service which would tend to cause overheating of the sparking plugs. Gaskets properly installed will have flat, clean surfaces. Gaskets which are approximately one-half their original thickness will be satisfactory but thinner ones should be renewed.

Examine the firing ends of the sparking plugs, noting the type of the deposits and the degree of electrode erosion. Remember that if insufficient voltage is delivered to the sparking plug, no type of plug can fire the mixture in the cylinder properly.

Normal condition—look for powdery deposits ranging from brown to greyish tan. Electrodes may be worn slightly. These are signs of a sparking plug of the correct heat range used under normal conditions—that is, mixed periods of high-speed and low-speed driving. Cleaning and regapping of the sparking plugs is all that is required. Watch for white to yellowish powdery deposits. This usually indicates long periods of constant speed driving or a lot of slow-speed city driving. These deposits have no effect on performance if the sparking plugs are cleaned thoroughly at approximately 3,000 mile (4,800 km.) intervals. Remember to "wobble" the plug during abrasive blasting in the service unit. Then scrape the sparking surfaces vigorously to expose bright, clean metal.

Oil fouling is usually indicated by wet, sludgy deposits traceable to excessive oil entering the combustion chamber through worn cylinders, rings, and pistons, excessive clearances between intake valve guides and stems, or worn and loose bearings, etc. Hotter sparking plugs may alleviate oil fouling temporarily but in severe cases engine overhaul is called for. Owners are strongly advised to contact Lotus Service Dept. for the correct grade before attempting this temporary expedient.

Petrol fouling is usually indicated by dry, black, fluffy deposits which result from incomplete combustion. Too rich an air/fuel mixture can cause incomplete burning. In

addition, a defective coil, contact breaker points, or ignition cable can reduce the voltage supplied to the sparking plug and cause misfiring. If fouling is evident in only a few cylinders sticking valves may be the cause. Excessive idling, slow speeds, or stop-and-go driving can also keep the plug temperatures so low that normal combustion deposits are not burned off.

Burned or overheated sparking plugs are usually identified by a white, burned, or blistered insulator nose and badly eroded electrodes. Inefficient engine cooling and improper ignition timing can cause general overheating.

Severe service, such as sustained high speed and heavy loads, can also produce abnormally high temperatures in the combustion chamber which necessitate the use of colder sparking plugs.

File the sparking surfaces of the electrodes by means of a point file. If necessary, open the gaps slightly and file vigorously enough to obtain bright, clean parallel surfaces. For best results hold the plug in a vice.

To reset the gaps, it is recommended that a special gap tool be used. Do not apply pressure on the centre electrode as insulator fracture may result. Use the bending fixture to obtain parallel sparking surfaces for maximum gap life.

Visually inspect all sparking plugs for cracked or chipped insulators. Discard all plugs with insulator fractures.

Test the sparking ability of a used spark plug on a comparator.

Clean the threads by means of a wire hand or power-driven brush. If the latter type is used wire size should not exceed .005 in. diameter. Do not wire-brush the insulator or the electrodes.

Clean the gasket seats on the cylinder head before installing sparking plugs to ensure proper seating of the sparking plug gaskets. Then, using a new gasket, screw in each plug by hand, finger-tight.

NOTE: *If the sparking plug cannot be seated on its gasket by hand clean out the cylinder head threads with a clean-out tap or with another used sparking plug having three or four vertical flutes filed in its threads.*

Great care must be experienced in tightening the sparking plugs. Any over tightening will strip the threads of the aluminium cylinder head. Plugs should be tightened using a torque setting of no more than 26 foot pounds.

Connect the H.T. terminals after the plugs are installed.

Standard Gap Setting

The sparking plug gap settings recommended and listed under "GENERAL DATA" have been found to give the best overall performance under all service conditions. They are based on extensive dynamometer testing and experience on the road and are generally a compromise between the wide gaps necessary for best idling performance and the small gaps required for the best high-speed performance.

All plugs should be reset to the specified gap by bending the side electrode only.

11—CONTACT BREAKER MECHANISM

After the first 500 miles (800 km.) and subsequently every 3,000 miles (4,800 km.) check the contact breaker as follows:

1. Turn the engine until the contact breaker points are fully opened and check the gap with a gauge having a thickness of from .014 to .016 in. (.36 to .40 mm.). If the gap is correct the gauge should be a sliding fit. Do not alter the setting unless the gap varies considerably from the gauge thickness. To adjust the setting keep the engine in the position which gives maximum opening of the contacts and then slacken the two screws securing the fixed contact plate. Adjust the position of the plate until the gap is set to the thickness of the gauge and then tighten the two locking screws. Remember that the cam only keeps the contact points fully open over a very small angle and that care must be taken to ensure that the points are in the fully open position.
2. If the contacts are dirty or pitted they must be cleaned by polishing them with fine carborundum stone and afterwards wiping them with a petrol moistened cloth. The moving contact can be removed from its mounting in order to assist cleaning. Check and adjust the contact breaker setting after cleaning the contacts.
3. Check that the moving arm moves freely on its pivot. If it is sluggish remove the moving arm and polish the pivot pin with a fine emery cloth. Afterwards clean off all trace of emery dust and apply a spot of clean engine oil to the top of the pivot. The contact breaker spring tension should be between 20 and 24 oz. (567 and 680 gm.) measured at the contacts.

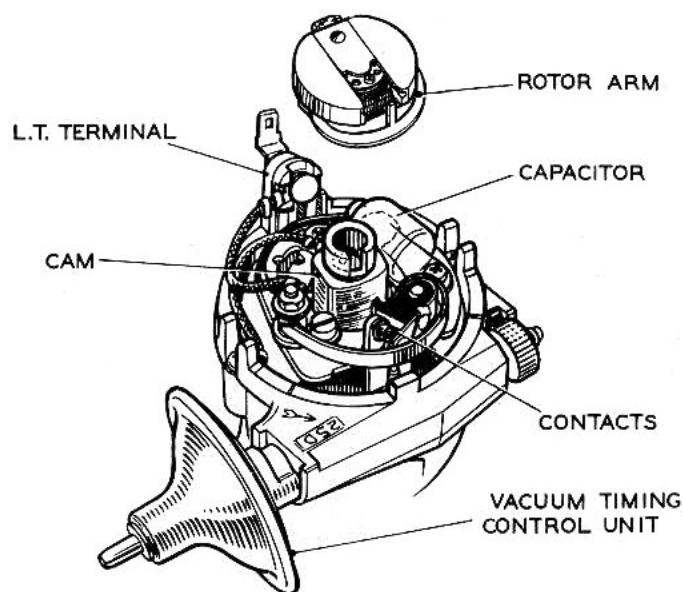

Fig. 15

The 25D4 distributor with the moulded cap and rotor arm removed, showing the contact breaker mechanism.

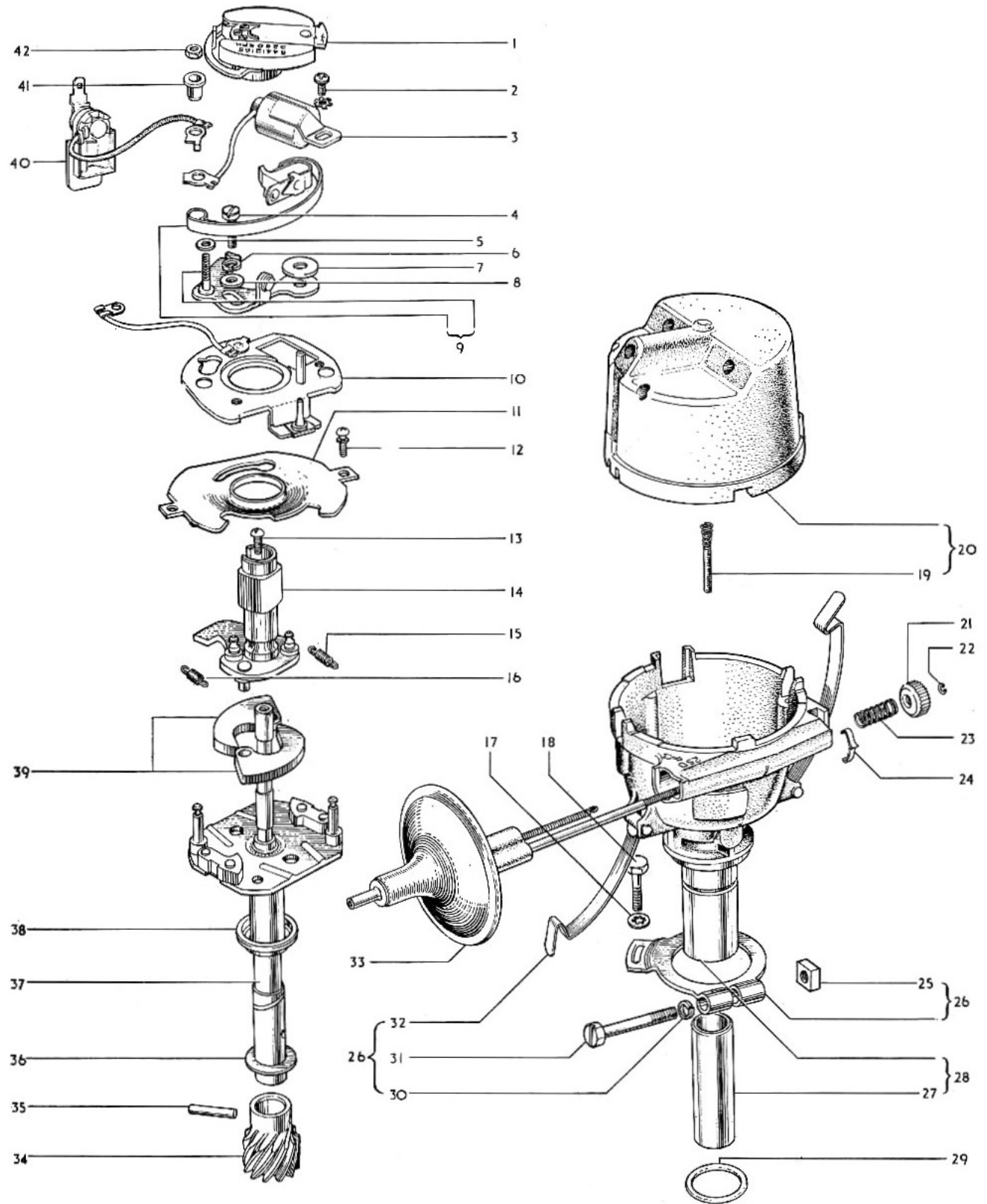

Fig. 16—25D DISTRIBUTOR COMPONENTS

FILE NOT TO BE REDISTRIBUTED FOR PROFIT ORIGINAL COPYRIGHT HOLDER LOTUS CARS LIMITED 1966

KEY TO THE 25D DISTRIBUTOR COMPONENTS

Key No.	Description
1	Rotor (distributor assembly)
2	Screw (condenser to breaker plate) and washer assembly
3	Condenser (distributor) assembly
4	Screw (adjusting bracket to breaker plate)
5	Washer (insulating)
6	Lockwasher
7	Washer (Distributor breaker arm pivot pin)
8	Washer
9	Contact set (distributor) assembly
10	Plate (distributor contact breaker)
11	Plate (distributor contact breaker bearing) assembly
12	Screw (bearing plate to body) and washer assembly
13	Screw (cam to shaft)
14	Cam (distributor) assembly
15	Kit (distributor automatic advance spring)
16	Kit (distributor automatic advance spring)
17	Washer
18	Bolt (distributor to cylinder block)
19	Brush (distributor H.T. and spring) assembly
20	Cap distributor assembly
21	Nut (distributor vacuum unit adjusting)
22	Ring (distributor vacuum unit adjusting nut retaining)
23	Spring (distributor vacuum unit adjusting nut)
24	Spring (distributor vacuum unit ratchet)
25	Nut
26	Arm (distributor timing) assembly
27	Bush (distributor base)
28	Body (distributor) clips and bearing bush assembly
29	Seal (distributor body to cylinder block)
30	Lock washer
31	Bolt (distributor clamp)
32	Clip (distributor body)
33	Unit (vacuum) and actuating arm assembly
34	Gear (distributor drive)
35	Pin (gear to distributor shaft)
36	Washer (distributor shaft thrust)
37	Shaft (distributor) and weight plate assembly
38	Washer (weight plate to body spacing)
39	Weight (distributor) assembly
40	Terminal (distributor low tension) assembly
41	Bush (contact adjusting bracket terminal insulating)
42	Nut (arm to bracket)

12—DISTRIBUTOR.—Removal

1. The distributor can be removed and replaced without interfering with the ignition timing provided the clamp plate pinch-bolt is not disturbed.
2. To facilitate the replacement of the distributor turn the engine over until the rotor arm is pointing to the segment in the cover for No. 1 cylinder plug lead to provide a datum for replacement. Also, ascertain the approximate position of the vacuum unit in order to replace the assembly in correct position.
3. Remove the distributor cover and disconnect the low-tension lead from the terminal on the distributor.
4. Extract the two bolts securing the distributor clamp plate to the distributor housing and withdraw the distributor.

IMPORTANT—On no account should the vacuum mechanism on 25D distributors be connected.

—Dismantling

The contact breaker plate may be removed as an assembly to give access to the centrifugal weights without completely dismantling the distributor. To do this first remove the rotor arm and then withdraw the slotted nylon low-tension terminal post from the distributor body.

Take out the two screws which secure the plate assembly to the distributor body, ease up the plate, and unhook the flexible actuating link connected to the contact breaker plate.

The following procedure is necessary if the distributor is to be completely stripped. Before dismantling, make a careful note of the positions in which the various components are fitted in order that they may be replaced correctly.

1. Spring back the clips and remove the moulded cap.
2. Lift the rotor off the top of the spindle. If it is a tight fit it must be levered off carefully with a screwdriver.
3. Remove the nut and washer from the moving contact anchor pin. Withdraw the insulating sleeve from the capacitor lead and low-tension lead connectors, noting the order in which they are fitted. Lift the moving contact from the pivot pin and remove the large insulating washer from the anchor pin.
4. Take out the screw and spring and flat washers securing the fixed contact plate and remove the plate.
5. Take out the securing screw and remove the capacitor.
6. Extract the two screws securing the base plate to the distributor body, noting that one also secures the earthing lead, and lift out the base plate.

IMPORTANT:—Note the relative position of the rotor arm drive slot in the cam spindle and the centrifugal weight action plate to ensure that the timing is not 180° out when the cam spindle is engaged with the centrifugal weights during reassembly.

7. Take out the cam retaining screw and remove the cam spindle.
8. Take out the centrifugal weights. These may be lifted out as two assemblies, each complete with a spring and toggle.

FILE NOT TO BE REDISTRIBUTED FOR PROFIT ORIGINAL COPYRIGHT HOLDER LOTUS CARS LIMITED 1966

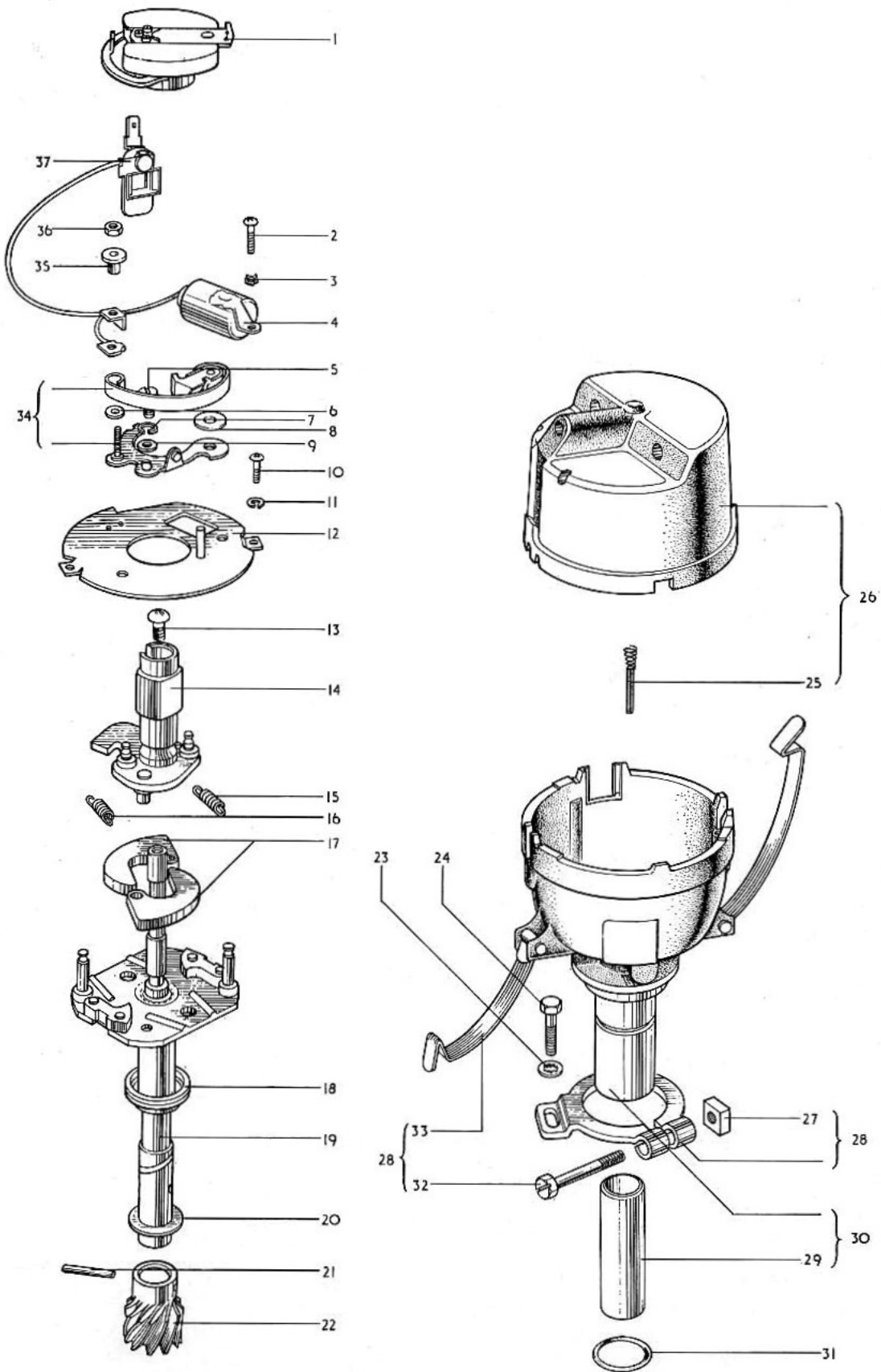

Fig. 17—23D DISTRIBUTOR COMPONENTS

KEY TO THE 23D DISTRIBUTOR COMPONENTS

Part No.	Description
1	Rotor
2	Screw (condenser to breaker plate)
3	Lockwasher (condenser to breaker plate)
4	Condenser
5	Screw (adjusting bracket to breaker plate)
6	Washer, insulating
7	Lockwasher
8	Washer (distributor breaker arm pivot pin)
9	Washer
10	Screw (bearing plate body)
11	Washer (bearing plate body)
12	Plate (distributor contact breaker bearing assembly)
13	Screw (cam to shaft)
14	Cam (distributor) assembly
15	Spring (distributor automatic advance)
16	Spring (distributor automatic advance)
17	Weight (distributor) assembly
18	Washer (weight plate to body spacing)
19	Shaft (distributor and weight pivot plate) assembly
20	Washer (distributor shaft thrust)
21	Pin (gear to distributor shaft)
22	Skew gear (distributor drive)
23	Washer (distributor to cylinder block)
24	Bolt (distributor to cylinder block)
25	Brush (distributor HT and spring) assembly
26	Cap (distributor) assembly
27	Nut
28	Arm (distributor timing) assembly
29	Bush (distributor base)
30	Body (distributor) clips and bearing bush assembly
31	Seal (distributor body to cylinder block)
32	Bolt (distributor clamp)
33	Clip (distributor body)
34	Contact set (distributor) assembly
35	Bush (contact adjusting bracket terminal insulating)
36	Nut (arm to bracket)
37	Terminal (distributors low tension) assembly

9. To release the in-operative suction advance unit, remove the circlip, adjusting nut, and spring. Withdraw the unit. Take care not to lose the adjusting nut lock spring clip.
10. To release the spindle from the body drive out the parallel driving pin passing through the collar of the skew gear at the lower end of the spindle.
11. Clean the distributor cover and examine it for signs of cracks and evidence of "tracking", i.e. a conducting path may have formed between the segments; when this has occurred the cover should be renewed.

12. Ensure that the carbon brush moves freely in the distributor cover.
13. Examine the attachment of the metal electrode to the rotor moulding. If slack or abnormally burned, renew the rotor.
14. The contact face of the contact breaker points should present a clean, greyish, frosted appearance. If burned or blackened, renew the contact set or polish the contact face of each point with a fine oil-stone, working with a rotary motion. Care should be taken to maintain the faces of the points flat and square, so that when re-assembled full contact is obtained. Clean the points thoroughly in petrol.
15. Check that the movable contact arm is free on its pivot without slackness.
16. Check the centrifugal timing control balance weights and pivot pins for wear, and renew the cam assembly or weights if necessary.
17. The cam assembly should be a free sliding fit on the driving shaft. If the clearance is excessive, or the cam face is worn, renew the cam assembly or shaft as necessary.
18. Check the fit of the shaft in the body bearing bushes. If slack, renew the bushes and shaft as necessary. Press out the old bushes. The new bushes should be allowed to stand completely immersed in thin engine oil for 24 hours, or alternatively for two hours in oil which has been heated to 212°F. (100°C.) before pressing them into the distributor body.

—Reassembly

Reassembly is a direct reversal of the dismantling procedure, although careful attention must be given to the following points:

1. As they are assembled, the components of the automatic advance mechanism the distributor shaft, and the portion of the shaft on which the cam fits must be lubricated with thin, clean engine oil.
2. Turn the vacuum control adjusting nut until it is in the half-way position when replacing the control unit. (25D4 units only).
3. When engaging the cam driving pins with the centrifugal weights make sure that they are in the original position. When seen from above, the small offset of the driving dog must be on the right, and the driving slot for the rotor arm must be in the six o'clock position.
4. Adjust the contact breaker to give a maximum opening of .014 to .016 in. (.36 to .40 mm.).

—Refitting

To replace the distributor insert it into the distributor housing of the engine, ensuring that the outer face of the rotor arm contact is in line with the low tension terminal on the distributor body and that the vacuum diaphragm spindle is parallel to the engine. When the distributor is pushed home the rotor arm will rotate towards the condenser as the skew gear engages. Turn the distributor body to align the clamping plate holes with those in the housing.

The remainder of the assembly is now in the reverse order to that of removal.

Provided that the engine has not been turned, the rotor arm will be opposite the segment for No. 1 plug lead. The high-tension leads can then be replaced on their respective plug terminals in the order of firing, i.e. 1, 3, 4, 2, remembering that the distributor rotation is anti-clockwise when viewed from above.

Normal ignition adjustment is given in Chapter 9.

NOTE: *If the clamping plate has been removed, or even slackened, resulting in lost timing, the procedure given in chapter 8 should be undertaken to reset the distributor.*

13—TIMING THE IGNITION

(a) Ignition Timing

For timing purposes there are three marks on the front of the timing chest adjacent to the crankshaft pulley.

As two types of distributor are fitted, it must be noted that the static advance "built in" to each engine is dependent on the type fitted. The three timing marks will however accommodate both advance settings.

Upper mark 20° B.T.D.C.
Middle mark 10° B.T.D.C.
Lower mark T.D.C.

For engines fitted with the 25D distributor (incorporating the inoperative vacuum unit) a static advance of 7° has been set, when No. 1 cylinder is on the compression stroke.

When the notch on the crankshaft pulley is turned to a 7° B.T.D.C. position, (i.e. between the middle and lower mark) the points will just be opening with the rotor adjacent to No. 1 cylinder's H.T. contact post in the distributor cap. (See fig. 18).

For engines fitted with the 23D distributor, the static advance has been increased to 14° B.T.D.C. Set the crankshaft pulley with the notch between the middle and upper mark in the 14° B.T.D.C. position.

NOTE:—*For reference purposes when the rotor head is adjacent to No. 1 cylinder H.T. contact post in the distributor cap it will give an approximately 10 o'clock position. (See fig 18).*

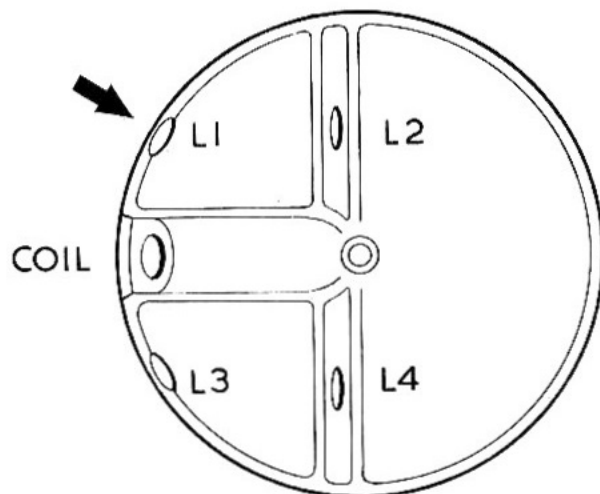

Fig. 18 Position of Rotor Arm. (Adjacent to No. 1 H.T. Terminal post in distributor body.)

(b) To Re-time the Ignition

Remove the sparking plugs and rotate the engine in a clockwise direction until No. 1 piston is at the top of its compression stroke. This can be ascertained by placing the thumb partially over the sparking plug orifice and feeling the increased pressure as the piston rises.

25D Distributor:

Continue turning slowly until the "notch" on the rim of the crankshaft pulley reaches a relative position at 7° between the 10° B.T.D.C. and T.D.C. marks on the timing scale adjacent to the pulley.

23D Distributor:

Turn until "notch" on the crankshaft pulley rim reaches the relative 14° B.T.D.C. position between upper and middle marks on the timing scale adjacent to the pulley.

If the distributor has been removed from the motor, check that the vacuum control unit spindle on 25D units is parallel with the engine before re-fitting. Set the rotor contact in line with the low tension terminal situated on the engine side of the distributor body. Re-fit the distributor noting that the rotor arm rotates in a clockwise direction as the helical gears mesh. Set the distributor clamp with the screw and lockwasher. Secure, but do not tighten. Rotate the distributor body in a clockwise direction and take up any backlash and until the points are just about to open. Lock the distributor clamp bolt by tightening. Before replacing the cap, finally check that the rotor arm is facing the contact in the cap for No. 1 cylinder H.T. lead.

IMPORTANT—To obtain an accurate setting the electrical method should be used in determining the precise position at which the points must break, and the following procedure should be adopted, with the use of a timing light.

When using a timing light it will be necessary to use a more advanced setting than the 7° and 14° static mentioned in chapter (a).

An 18° B.T.D.C. mark should be inserted between the middle and upper marks on the timing chest. This mark will simulate an advance setting for the idling speed of the engine. It will suffice for both 25D and 23D distributors as both advance characteristics align themselves at 800—1000 r.p.m.

Connect the two main leads of a timing light to the terminals of a 12v. battery, taking care to ensure that the positive lead is connected to the positive terminal, etc. Connect the third lead to the L.T. terminal of the distributor.

With the timing light in the vicinity of the crankshaft pulley, rotate the engine and check when the bulb is illuminated, that the mark on the crankshaft pulley is adjacent to the 18° B.T.D.C. mark on the timing chest.

If the pulley notch appears above the 18° position the timing is too far advanced, and the distributor body clamp must be slackened and the unit turned slightly anti-clockwise to retard. Should the pulley notch appear below the 18° position then the distributor should be rotated slightly clockwise to advance it. Tighten the clamp bolt after the necessary adjustments have been made.

GENERATOR MODEL C.40—1
Part No. 22700

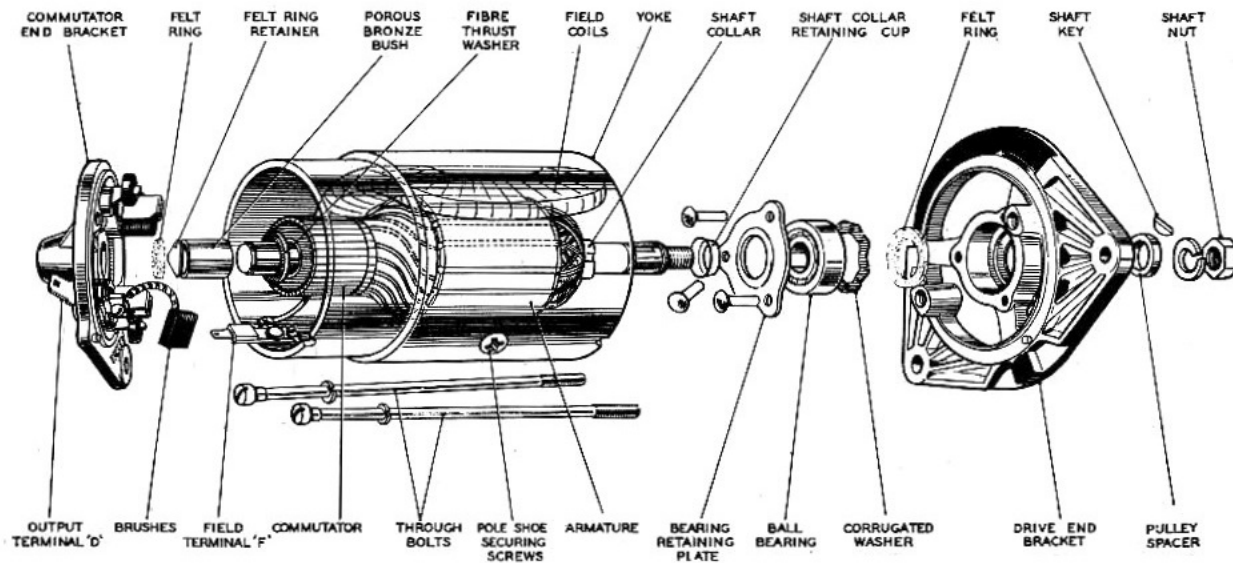

Fig. 19 C.40—1 Generator Dismantled

14—GENERAL DESCRIPTION

The generator is a shunt-wound two-pole two-brush ventilated machine, arranged to work in conjunction with a Lucas regulator unit. Holes in each end bracket allow a pulley-mounted fan to draw cooling air through the generator.

This machine is designed for use with a 5 in. diameter fan and current-voltage control under which circumstances its maximum output of 22 amperes can be safely taken. When a 4½ in. diameter fan is used the maximum output must be limited to 20 amperes. The effective output is slightly reduced when compensated voltage control is used with either fan size.

15—ROUTINE MAINTENANCE

(a) Lubrication

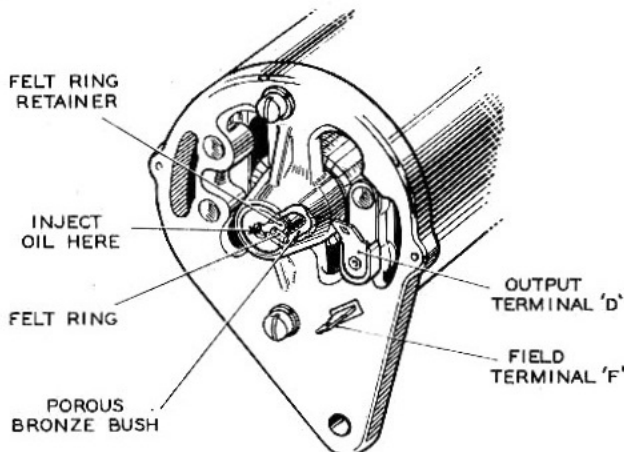

Fig. 20 Lubricator in commutator end bracket

Every 6,000 miles or every 6 months, whichever occurs first, inject a few drops of high quality S.A.E. 30 engine oil into the hole marked "OIL" at the end of the C.E. bearing housing.

(b) Inspection of Brushgear

At 24,000 miles the generator should be removed from the engine and the brushgear be inspected by a competent automobile electrician (see para. 17 (c)).

(c) Belt Adjustment

Occasionally inspect the generator driving belt and, if necessary, adjust to take up any undue slackness by turning the generator on its mounting. Care should be taken to avoid over-tightening the belt, the tension needed being just enough to drive without slipping. See that the machine is properly aligned, otherwise undue strain will be thrown on the generator bearings.

16—PERFORMANCE DATA

Cutting-in Speed : 1,450 r.p.m. (max) at 13.0 generator volts.

Max. Output : 22 amp. at 2,250 r.p.m. (max.) at 13.5 generator volts and a resistance load of 0.61 ohm.

Field Resistance : 6.0 ohms.

17—SERVICING

(a) Testing in Position to Locate Fault in Charging Circuit

In the event of a fault in the charging circuit, adopt the following procedure to locate the cause of trouble:

- (i) Inspect the driving belt and adjust if necessary.
- (ii) Check the Lucas connections on the commutator

end bracket. The larger connector carries the main generator output, the smaller connector the field current.

- (iii) Pull off the connectors from the terminal blades of the generator and connect the two blades with a short length of wire.
- (iv) Start the engine and set to run at normal idling speed.
- (v) Clip the negative lead of a moving coil type voltmeter, calibrated 0—20 volts, to one generator terminal and the positive lead to a good earthing point on the yoke.
- (vi) Gradually increase the engine speed, when the voltmeter reading should rise rapidly and without fluctuation. Do not allow the voltmeter reading to reach 20 volts and do not race the engine in an attempt to increase the voltage. It is sufficient to run the generator up to a speed of 1,000 r.p.m. If the voltage does not rise rapidly and without fluctuation the unit must be dismantled for internal examination (see Para. 17 (b)). Excessive sparking at the commutator in the above test indicates a defective armature which should be replaced.

NOTE: If a radio suppression capacitor is fitted between the output terminal and earth, disconnect this capacitor and re-test the generator before dismantling. If a reading is now given on the voltmeter, the capacitor is defective and must be replaced.

If the generator is in good order, remove the link from between the terminals and restore the original connections.

(b) To Dismantle

- (i) Take off the driving pulley.
- (ii) Unscrew and withdraw the two through bolts.
- (iii) Withdraw the commutator end bracket from the yoke.
- (iv) Lift the driving end bracket and armature assembly from the yoke. Take care not to lose the fibre thrust washer(s) from the commutator end of the shaft.
- (v) The driving end bracket, which on removal from the yoke has withdrawn with it the armature and armature shaft ball-bearing, need not be separated from the shaft unless the bearing is suspected and requires examination, or the armature is to be replaced; in this event the armature should be removed from the end bracket by means of a hand press, having first removed the shaft key.

(c) Brushgear (Checking with Yoke Removed)

- (i) Lift the brushes up into the brush boxes and secure them in that position by positioning the brush springs at the sides of the brushes.
- (ii) Fit the commutator end bracket over the commutator and release the brushes.
- (iii) Hold back each of the brush springs and move the brush by pulling gently on its flexible connector. If the movement is sluggish, remove the brush from its holder and ease the sides by lightly polishing on

a smooth file. Always refit brushes in their original positions. If the brushes are badly worn, new brushes must be fitted and bedded to the commutator. The minimum permissible length of brush is $\frac{9}{32}$ in.

- (iv) Test the brush spring pressures using a spring balance held radially to the commutator. With a commutator diameter of 1.480 in.—1.485 in., these pressures should be 30 oz., maximum, when exerted on a new brush and 13 oz., minimum, on a brush worn to $\frac{9}{32}$ in. Both pressures should be measured. Fit new springs if the tension is low.

(d) Commutator

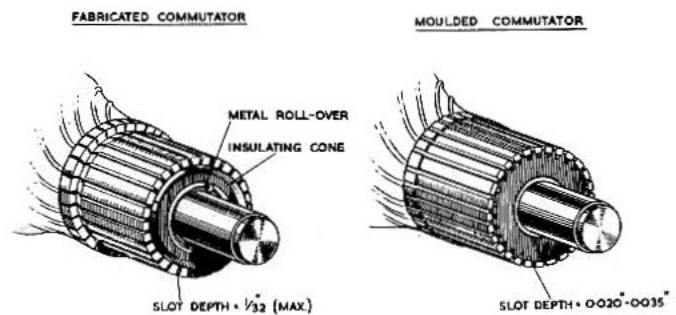

Fig. 21 Commutator Types

A commutator in good condition will be smooth and free from pits or burned spots.

Whilst the C.40 Generator was designed to accommodate a commutator of moulded construction, production also includes machines having commutators of the fabricated type. Moulded commutators can be recognized by the exposed end being quite smooth unlike that of fabricated commutators from which a metal roll-over and an insulating cone protrude.

A moulded commutator can be re-skimmed during service, but care must be exercised to ensure that the finished diameter is not less than 1.45 in. The process of re-skimming consists of rough turning, (if necessary) and diamond turning. Whether or not rough turning is carried out depends upon the severity and unevenness

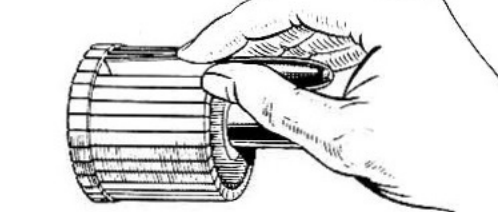
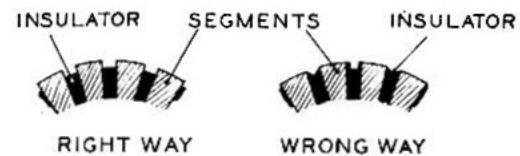

Fig. 22 Undercutting Commutator Segments

of wear which has taken place. If a moulded commutator cannot be completely cleaned up without going below the specified diameter, the armature should be replaced. A moulded commutator requires no undercutting in service, the production undercut being of sufficient depth to obviate any further need for this in service. The insulation slots should, however, be kept clear of copper and carbon residue.

To remedy a worn fabricated commutator, undercut the insulators between the segments to a depth of $\frac{1}{32}$ in., then take a light skim with a very sharp (preferably diamond-tipped) tool. If a non-diamond-tipped tool is used for machining, the commutator should afterwards be lightly polished with a very fine glass-paper—never emery cloth.

(e) Armature

Indication of an open-circuited armature winding will be given by burnt commutator segments. If armature testing facilities are not available, an armature can be checked by substitution. To separate the armature shaft from the drive end bracket, press the shaft out of the drive end bracket bearing. When fitting the new armature, support the inner journal of the ball bearing, using a mild steel tube of suitable diameter, whilst pressing the armature shaft firmly home.

(f) Field Coils

Measure the resistance of the field coils, without removing them from the generator yoke, by means of an ohm meter connected between the field terminal and the yoke.

Field resistance is 6.0 ohms.

If an ohm meter is not available, connect a 12-volt d.c. supply between the field terminal and generator yoke with an ammeter in series. The ammeter reading should be approximately 2 amperes. Zero reading on the ammeter or an "Infinity" ohm meter reading indicates an open circuit in the field winding.

If the current reading is much more than 2 amperes, or the ohm meter reading much below 6 ohms, it is an indication that the insulation of one of the field coils has broken down.

In either event, unless a substitute generator is available, the field coils must be replaced. To do this, carry out the procedure outlined below:

- (i) Drill out the rivet securing the field coil terminal assembly to the yoke and remove the insulating sleeve from the terminal blade to protect it from the heat of soldering.
- (ii) Unsolder the terminal blade and earthing eyelet.
- (iii) Remove the insulation piece which is provided to prevent the junction of the field coils from contacting with the yoke.
- (iv) Mark the yoke and pole shoes so that the latter can be refitted in their original positions.
- (v) Unscrew the two pole shoe retaining screws by means of a wheel-operated screwdriver.
- (vi) Draw the pole shoes and coils out of the yoke and lift off the coils.

- (vii) Fit the new field coils over the pole shoes and place them in position inside the yoke. Take care to ensure that the taping of the field coils is not trapped between the pole shoes and the yoke.
- (viii) Locate the pole shoes and field coils by lightly tightening the fixing screws.
- (ix) Fully tighten the screws by means of the wheel-operated screwdriver.
- (x) Solder the original terminal blade and earthing eyelet to the appropriate coil ends.
- (xi) Refit, by using a new rivet, the field coil terminal assembly to the yoke.
- (xii) Refit the insulation piece behind the junction of the two coils.

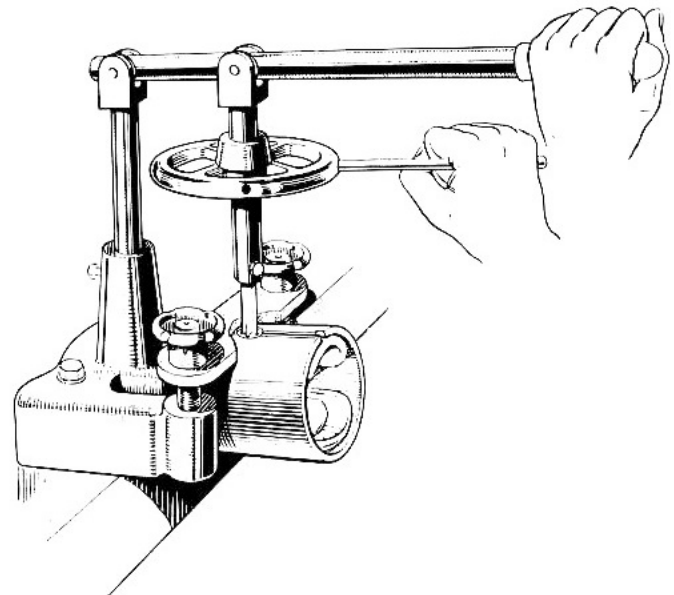

Fig. 23 Tightening pole shoe retaining screws

(g) Bearings

Bearings which are worn to such an extent that they will allow side movement of the armature shaft must be replaced.

To replace the bearing bush in a commutator end bracket, proceed as follows:

- (i) Remove the old bearing bush from the end bracket. The bearing can be withdrawn with a suitable extractor or by screwing a $\frac{5}{8}$ in. tap into the bush for a few turns and pulling out the bush with the tap. Screw the tap squarely into the bush to avoid damaging the bracket.
- (ii) Withdraw and clean the felt ring retainer and felt ring.
- (iii) Insert the felt ring and felt ring retainer in the bearing housing, then press the new bearing bush into the end bracket, using a self-extracting tool of the type and in the manner shown in Fig. 6—the fitting pin or mandrel portion being of 0.5924 diameter and highly polished. To withdraw the pin after pressing the bush fully home, turn the

nut against the sleeve while gripping the squared end of the fitting pin.

Porous bronze brushes must not be opened out after fitting or the porosity of the bush may be impaired.

NOTE: Before fitting the new bearing bush, it should be allowed to stand for 24 hours completely immersed in a good grade S.A.E. 30 engine oil; this will allow the pores of the bush to be filled with lubricant.

The ball bearing at the driving end is replaced as follows:

- (i) Drill out the rivets which secure the bearing retaining plate to the end bracket and remove the plate.
- (ii) Press the bearing out of the end bracket.
- (iii) Remove and clean the corrugated washer and felt ring.
- (iv) Before fitting the replacement bearing, see that it is clean and pack it with high melting point grease, such as Energrease RBB.3.
- (v) Place the felt ring and corrugated washer in the bearing housing in the end bracket.
- (vi) Locate the bearing in the housing and press it home.

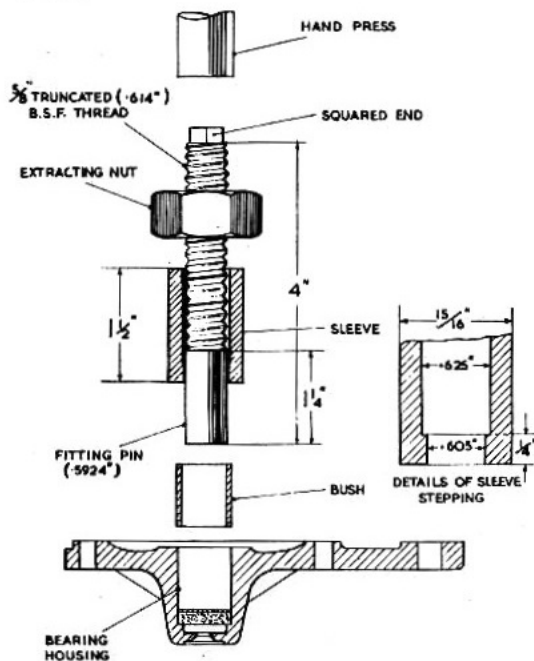

Fig. 24 Fitting Generator Bearing Bush

(h) To Reassemble

- (i) Fit the drive end bracket to the armature shaft. The inner journal of the bearing must be supported by a tube, approximately 4 in. long, $\frac{1}{8}$ in. thick and internal diameter $\frac{5}{8}$ in. Do not use the drive end bracket as a support for the bearing whilst fitting an armature.
- (ii) Fit the yoke to the drive end bracket.
- (iii) Push the brushes up into the brush boxes and secure them in that position by positioning each

METHOD OF TRAPPING BRUSH IN RAISED POSITION WITH SPRING

METHOD OF RELEASING BRUSH ON TO COMMUTATOR

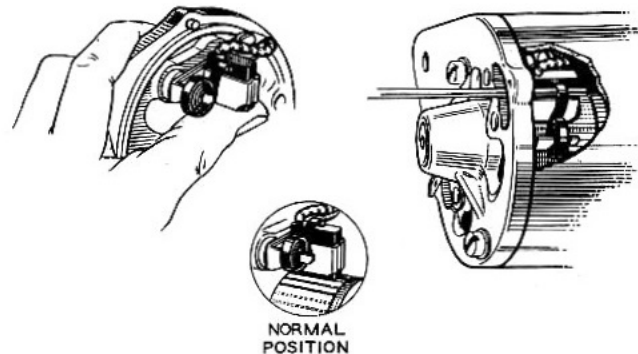

Fig. 25

Fitting C.E. Bracket to "Windowless" Yoke Generator.

brush spring at the side of its brush.

- (iv) Fit the fibre thrust washer(s) to the shaft and the commutator end bracket to the yoke, so that the dowel on the bracket locates with the groove on the yoke. Take care not to trap the brush connector pigtails. Insert a thin screwdriver through the ventilator holes adjacent to the brush boxes and gently lever up the spring arms until the brushes locate correctly with the armature.
- (v) Refit the two through bolts, pulley spacer and shaft key.
- (vi) After reassembly lubricate the commutator end bearing see para. 15 (a).
- (vii) Fit the bearing retaining plate. Insert the new rivets, opening them by means of a punch to secure the plate rigidly in position.

18—CONTROL BOX MODEL RB106—2

ELECTRICAL SETTINGS

All settings are accurately adjusted before control boxes leave the factory and must not be disturbed unnecessarily. Any subsequent attention which may be required after the period of guarantee has expired should only be carried out by a qualified automobile electrician.

(a) Preliminary Check of Charging Circuit

Before disturbing any electrical adjustments, examine as follows to ensure that the fault does not lie outside the control box:

- (i) Check the battery by substitution or with a hydrometer and a heavy discharge tester.
- (ii) Inspect the generator driving belt. This should be just taut enough to drive without slipping.
- (iii) Check the generator by substitution or by linking large terminal "D" to small terminal "F" and connecting a voltmeter between this link and earth and running the generator up to about 1,000 r.p.m. when a rising voltage should be shown.
- (iv) Inspect the wiring of the charging circuit and carry out continuity tests.

- (v) Check earth connections, particularly those of the control box.
- (vi) In the event of undercharging, ascertain that this is not due to low mileage.
- (vii) If the foregoing checks do not serve to diagnose the fault and the control box is required to be checked then refer to an electrician with the necessary qualifications and test equipment.

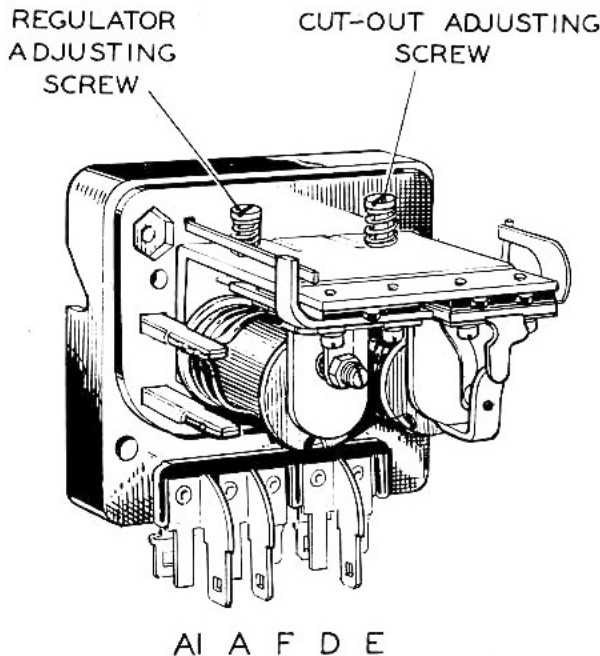

Fig. 26 Control Box Model R.B. 106/2

(b) Check Regulator Electrical Setting

Checking and adjusting should be completed as rapidly as possible to avoid errors due to heating of the shunt coil.

- (i) Connect a first-grade 0—20 moving-coil voltmeter between control box terminals “D” and “E”.
- (ii) Disconnect terminal “A” and “A1”, withdraw the cables and connect them together.
- (iii) Run the generator at 3,000 r.p.m. and observe the voltmeter reading. This should lie between the appropriate limits, as follows:

Ambient Temperature	Open-circuit Voltage
10°C. (50°F.)	16.1—16.7
20°C. (68°F.)	16.0—16.6
30°C. (86°F.)	15.9—16.5
40°C. (104°F.)	15.8—16.4

An unsteady reading may be due to unclean contacts but if the reading is outside the appropriate limits an adjustment must be made.

(c) Regulator Electrical Adjustment

- (i) Remove the control box cover.
- (ii) Restart the engine and run the generator at 3,000 r.p.m.

- (iii) Turn the voltage adjustment screw (clockwise to raise the setting or anti-clockwise to lower it) until the correct setting is obtained.
- (iv) Check the setting by stopping the engine and then again raising the generator speed to 3,000 r.p.m.
- (v) Restore the original connections and refit the control box cover.

(d) Checking Cut-out Relay Electrical Setting

Checking and adjusting should be completed as rapidly as possible to avoid errors due to heating of the shunt coil.

- (i) Connect a first-grade 0—20 moving-coil voltmeter between control box terminals “D” and “E”.
- (ii) Remove the control box cover in order to note the instant of contact closure. Alternatively, switch on an electrical load such as a pair of headlamps when the instant of contact closure will be indicated by a slight flick in the voltmeter reading.
- (iii) Start the engine and slowly increase its speed.
- (iv) Observe the voltmeter pointer. If the flick occurs outside the limits, 12.7—13.3 volts, and adjustment must be made.

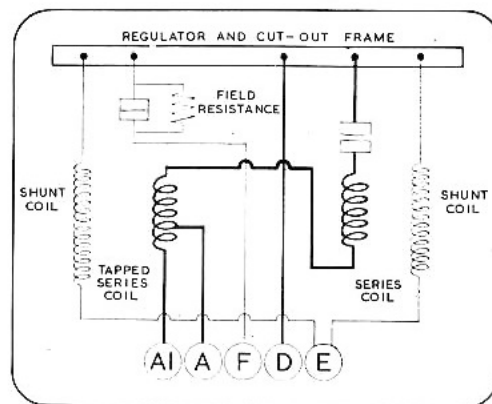

Fig. 27 Internal Connections Control Box

(e) Cut-out Relay Electrical Adjustments

- (i) **Method of Cut-in voltage adjustment:**
Remove the control box cover.
Turn the cut-out relay adjustment screw (clockwise to raise the setting and anti-clockwise to lower it) until the correct setting is obtained.
Recheck the setting by increasing the engine speed from zero.
Restore the original connections and refit the cover.
- (ii) **Method of Drop-off Adjustment**
Disconnect the cables from control box terminals “A” and “A1” and join these cables together.
Connect a first-grade 0—20 moving-coil voltmeter between terminal “A” or “A1” and earth.
Start the engine and run up to speed.
Slowly decelerate and observe the voltmeter pointer.

Opening of the contacts, indicated by the voltmeter pointer dropping to zero, should occur between the limits 8.5—11.0 volts. If the drop-off occurs outside these limits, an adjustment must be made.

In this event, continue as follows:

- (i) Stop the engine and remove the control box cover.
- (ii) Adjust the height of the fixed contact by carefully bending the fixed contact blade towards the bobbin to reduce the drop-off voltage or away from it to raise the drop-off voltage.
- (iii) Recheck the setting and, if necessary, re-adjust until the correct drop-off setting is obtained.
- (iv) Restore the original connections and refit the cover.

(f) Cleaning Contacts

(i) Regulator Contacts

To clean the voltage regulator contacts, use fine carborundum stone or silicon carbide paper.

(ii) Cut-out Relay Contacts

To clean the cut-out relay contacts, use a strip of fine glass paper—never carborundum stone or emery cloth.

19—MINIATURE WIND-TONE HORNS LUCAS MODEL 9H

GENERAL DESCRIPTION

The LOTUS ELAN is fitted with Lucas miniature wind-tone horns, models 9H, operated on the well-known principle of a resonating air column vibrated by means of a diaphragm actuated electro-magnetically by a self-interruptory circuit. The horns are intended to be sounded in matched pairs, each pair consisting of a high note and a low note horn—the notes differing by a definite musical interval. The weight of a single horn is approximately 1½ lb.

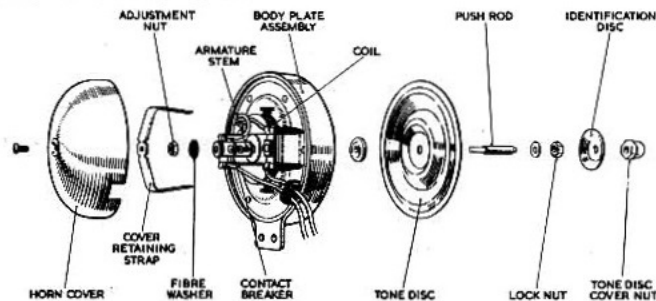

Fig. 28 9H Wind-tone Horn—exploded components

20—MAINTENANCE AND ADJUSTMENT

(a) Maintenance

Before being passed out of the works, every horn is adjusted to give its best performance. It should require no further attention until it has given a long period of service.

If a horn fails to sound or its performance becomes uncertain, the fault will not necessarily be in the horn. First see that the trouble is not due to such defects as a loose or broken connection in the wiring of the horn circuit or to a discharged battery. A short circuit in the horn wiring will cause the fuse (when fitted) to blow. In this event, examine the wiring for the fault and rectify

accordingly, before renewing the fuse with the spare provided. Poor performance can also be caused by loosening of the fixing bolts. Check and tighten as necessary.

If examination shows the above points to be in order the horn may need adjustment but this should not become necessary until the horns have been in service for a long period.

(b) Adjustment

As two horns are fitted, disconnect one whilst adjusting the other, taking care to ensure that the supply cable removed does not come into contact with any part of the vehicle metalwork. Adjustment does not alter the pitch of the note but merely takes up wear of moving parts. While adjusting, short out the fuse (if fitted), otherwise it may blow. If a horn does not sound after making an adjustment, release the horn push or ring instantly.

A small serrated adjustment screw is provided on that side of the horn at which the cables terminate. Turn this screw anti-clockwise until the horn just fails to sound, then turn it back for about one quarter of a turn.

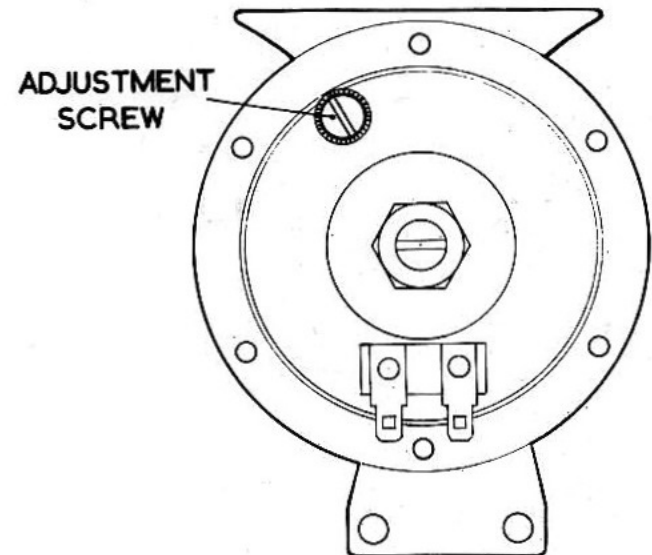

Fig. 29 Adjustment Screw 9H. Horn

Warning: It is essential that the central slotted stem and locking nut are not disturbed.

(A 12-volt horn in correct adjustment will pass 3.0—3.5 amperes—measured on a first-grade moving-coil 0—10A. ammeter. If a suitable instrument is available, connect it in series with the horn and turn the adjustment screw clockwise to increase the current, or anti-clockwise to decrease it. When adjusting a horn by the aid of an ammeter, the aim is to obtain the best performance with the least current).

21—CLEAR HOOTERS MINIATURE WIND-TONE HORNS

Later models of the Lotus Elan are equipped with the Clear Hooter type horn. Adjustment of these instruments is similar to that of the LUCAS model 9H. type.

22—MODEL LA 12 IGNITION COIL. Part No. 45111

Occasionally, check the terminals for tightness and inspect the high tension cable for signs of wear. It is essential that the exterior of the coil is kept clean and dry.

The primary resistance should be 3.0—3.4 ohms.

23—MODEL 2ST. SOLENOID Part No. 76464

This requires no maintenance apart from keeping the terminals clean and tight and the solenoid body free from grease and dirt.

24—MODEL 4FJ FUSE UNIT Part No. 54038033

This unit carries two "live" and two spare fuses each rated at 35 amperes. Replacement fuses can be obtained under Lucas Part No. 188218.

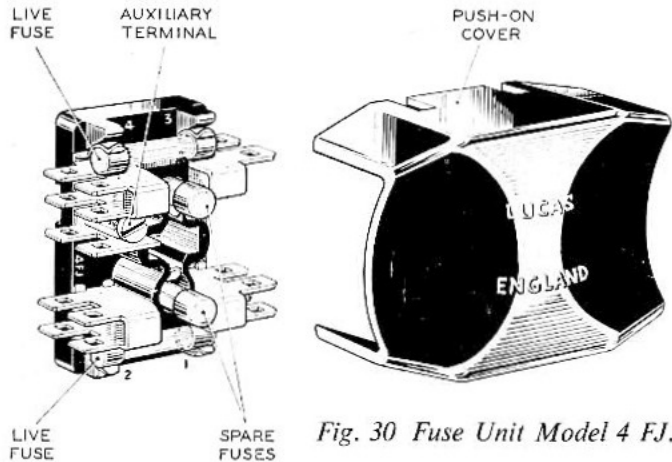

Fig. 30 Fuse Unit Model 4 FJ.

25—WINDSCREEN WIPER MODEL DR3A Part No. 75501

GENERAL DESCRIPTION

The Lucas windscreen wiper model DR3A comprises an electric motor and gearbox driving a cable rack mechanism which transmits power to the wheelbox spindles and so to the wiper arms and blades. Rotation of the motor armature is converted to a reciprocating motion in the cable rack by means of a single-stage worm and nylon gear, the motor end of the cable rack being coupled to the crank pin on the gear through a cross-head and connecting rod in the gearbox.

A self-switching feature ensures that the arms and the blades return automatically to the edge of the windscreen before stopping, irrespective of their positions at the instant of switching off. This is effected by means of a limit switch in the gearbox, its action being controlled by the crankpin. For the greater part of each cycle the limit switch contacts are closed, providing an alternative earth return path for the motor current. Each time the blades reach the edge of the windscreen at which they are normally parked when the wiper is not in use, the limit switch opens. Thus, when the control switch is turned to OFF, the motor continues to run until the blades reach their parked position.

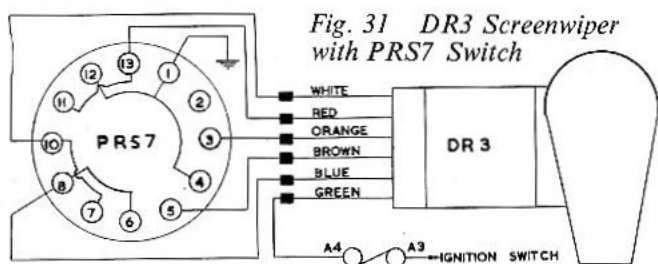

Fig. 31 DR3 Screenwiper with PRS7 Switch

26—MAINTENANCE

The gearbox, cable rack and wheelboxes are greased during manufacture and need no periodic lubrication.

Efficient wiping is dependent upon having a clean windscreen and wiper blades in good condition. Oil, tar spots or other contaminations should be removed from the screen with methylated spirits. Silicone or wax polishes must not be used for this purpose.

Worn or perished wiper blades are readily removed for replacement. (See fig. 35).

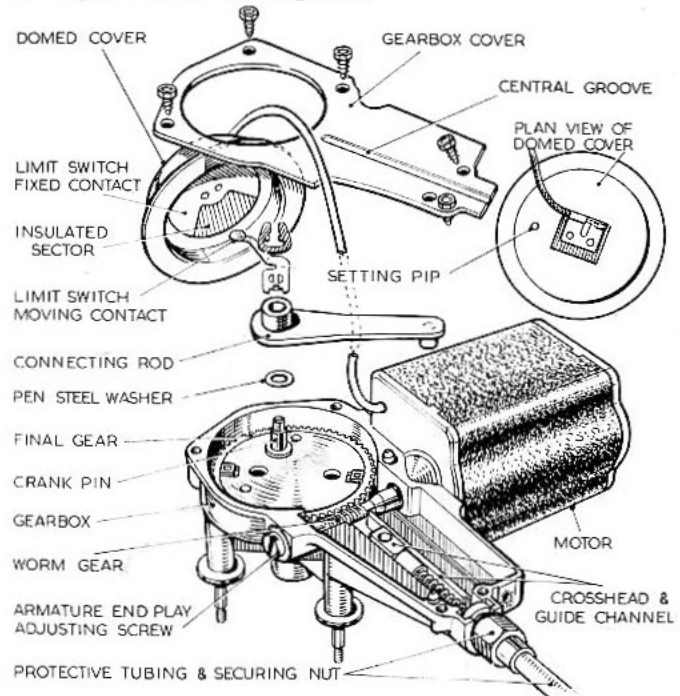

Fig. 32 Windscreen Wiper Model DR3A.

27—DATA

Light running current after 60 seconds	2.7—3.4 amperes
(Cable rack disconnected)			
Light running speed after 60 seconds	45—50 r.p.m. of final gear.
Armature end play:	0.008—0.012 in. (0.2—0.3 mm.)
Maximum permissible force to move cable rack in outer tubings	6.0 lb. (2.7 kg.).

28—SERVICING

(a) Failure to Operate or Poor Performance

If the windscreen wiper fails to operate, or gives poor performance, the fault may be either electrical or mechanical. To locate the cause of the trouble, proceed as follows:

(i) Measure Supply Voltage.

Using a first-grade moving-oil voltmeter, measure the voltage between the supply terminal at the motor and a good earthing point, with the control switch ON. For a motor operating normally, this will be about 11.5 volts.

If there is zero voltage reading, check fuse, switch, cables and connections.

If there is a low voltage reading, i.e. appreciably below 11.5 volts, excessive current flow in the motor is indicated, caused by either an internal fault or excessive mechanical loading in the cable rack transmission.

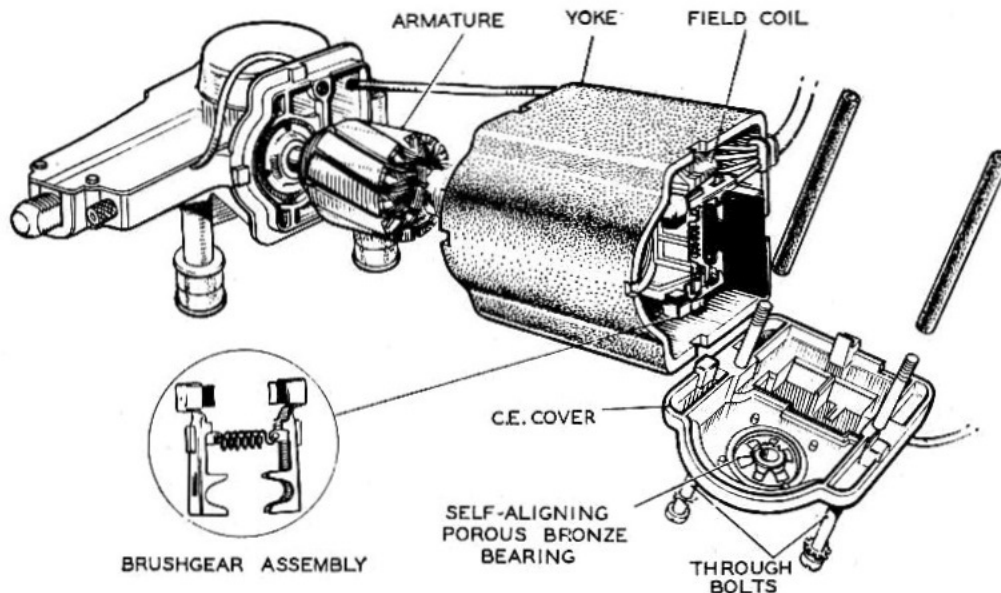

Fig. 33 Windscreen Wiper Model DR3

- (ii) **Measure Light Running Current and Speed.** Disconnect the cable rack at the gearbox. To do this, first mark the position of the domed limit switch cover with relation to the gearbox cover. Withdraw the four self-tapping screws which secure the gearbox cover and lift off the cover. Take off the spring clip which secures the connecting rod on the crank pin, also removing the rotating limit switch contact. The connecting rod can now be lifted off. Connect a first-grade moving-coil ammeter in the motor supply cable and measure the light running current. Also observe the operating speed by counting the speed of rotation of the final gear. The light running current should not exceed 3.4 amperes, and the gear speed should be 44–50 r.p.m. (after running for 60 seconds). If the motor does not run, or the light running current and speed are not as stated, an internal fault in the motor is indicated; a replacement motor should be fitted, or the motor removed for further examination by a qualified automobile electrician.

- (iii) **Check Cable Rack, Tubing and Wheelboxes.** If the light running current and speed are correct, then the cause of the trouble most probably lies in the cable rack transmission. The maximum permissible force to move the cable rack in its protective tubing is 6 lb. (2.7 kg). This can be checked while the cable rack is disconnected from the gearbox. First take off the arms and blades, then hook a spring balance into the hole in the crosshead into which the pin on the

connecting rod is normally fitted. Withdraw the rack with the balance, noting the force required. Binding of the rack can be due to kinked or flattened tubing, or to faulty installation. Any badly kinked or flattened tubing must be renewed.

Any curves of less than 9 inch (23 cm.) radius must be reformed. The cable rack should be well lubricated with Ragosine Listate or Duckham's HBB grease. When the cable rack is removed, check the wheelboxes for looseness, misalignment or binding of the spindle, and rectify or replace as necessary.

- (iv) **Reconnecting Cable Rack.** This is a reversal of the procedure outlined above taking care to refit the domed limit switch cover in its original position. Ensure that the hexagon nut which secures the tubing to the gearbox is not cross-threaded.

(b) **Fitting Wiper Arms**

RETAINING CLIP

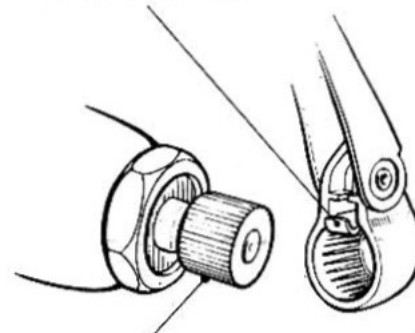

SPLINED DRIVING DRUM

Fig. 34 Renewal and Replacement of the Wiper Arm.

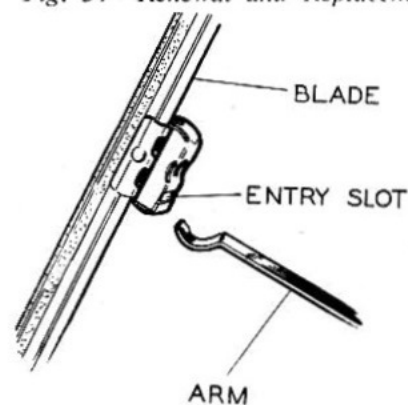

Fig. 35 Renewal and Replacement of the Wiper Blade.

NOTE:—Wipers also in use on the Lotus Elan employ an arm having a straight shank, and an end entry slot fitting on the blade. Both models have a small boss location at the extremity of the arms.

Before refitting wiper arms after removal, ensure that the wheelbox spindles are in the correct parking position, by switching on the motor and then switching off and waiting for them to come to rest at the end of a cycle. Fit the arms and blades to the splined driving drums on the wheelbox spindles at the correct parking angle until the retaining clip snaps over the end of the drum. Switch on and note the wiped areas. If necessary, the position of the arms can be adjusted by removing and re-engaging them in the appropriate position, the pitch of the driving drum splines being 5°. Do not attempt to turn the arms on the spindles, but press back the retaining clip and withdraw the arms from the driving drums.

(c) Limit Switch Adjustment

The correct working of the limit switch is obtained when the setting pip on top of the domed cover is in line with (in a position either nearest to or furthest from) the central groove in the gearbox cover. Parking of the blades in the opposite extreme position can be effected by slackening the four gearbox cover screws and rotating the limit switch cover through 180° before retightening the screws.

29—LAMP UNITS — HEAD LAMPS

(a)—Beam Setting

Headlamps should be set so that when the car carries its normal load, the driving beams are projected straight ahead parallel with each other and with the road surface.

Many garages possess a Lucas Beam Setter. These are scientific instruments enabling accurate beam setting to be effected. The car owner is strongly advised to make use of this service whenever possible. When such facilities are not available, the lamps can be set by marking off a smooth wall or screen and shining the lamps on it from a distance of twenty-five feet.

An adjustable bolt stop, limiting the travel of the retractable lamp assemblies on the Elan will be found to have more than adequate adjustment length, for vertical beam trimming.

Release the locknut on each unit in turn and screw bolt stop in or out to achieve the desired position of the lamp bowl assembly in the "up" position.

Further beam trimming can be effected within the lamp unit itself both in vertical and horizontal position.

To avoid damaging the paintwork of the bowl assemblies when removing the clip-on rims, it is suggested that a simple tool be made as per illustration (page L 28)

With the lamp unit in "up" position carefully insert tool in outside edge of unit between rim and rubber gasket and slide round rim to bottom of rim. Apply a sharp tug in forward direction and the rim will pull clear of the lamp unit. Lift off the dust excluding rubber ring. This is approximately I. shaped in section and is intended to be positioned with the toe of the "L" facing rearwards.

NOTE:—*Later models are now not fitted with the "L" shaped dust excluder ring.*

Vertical trimming is effected by screwing in (or out) the top adjustment screw between lens back plate and lamp body.

Horizontal trimming is effected by the side adjustment screw. Replace the rim by engaging rim edge over raised lip at top of lamp body.

(b) Bulb Replacement

Remove the clip-on rim as outlined in previous chapter, lift off dust excluder rubber ring, unscrew the three Philips beaded self-tapping screws and remove the chromium bezel that clamps the sealed beam unit to the backplate. Pull the wiring plug away from the rear of the lamp unit and replace defective unit using a reversal of the procedure outlined above.

NOTE: *For reference purposes the standard Lucas sealed beam unit fitment to the Elan is numbered MB—60/7002—12/8v.—60/45w.—RHD.*

30—L691/692 FRONT DIRECTION INDICATOR LAMPS

Bulb Replacement

Unscrew the two Philips headed screws and remove the securing lens to body. The bulb is a single filament bayonet fixing type No. 382 12v. 21w.

31—L658 FRONT SIDE LAMPS

Bulb Replacement

The lens complete with chrome bezel is removed from body by pressing slightly and turning in an anti-clockwise direction. Replace defective bulb with a bayonet fixing 12v. 6w. single filament type.

Note on lens replacement: In order to position a clear portion of the lens to the outside of the car it should be noted that the bayonet lugs are of different size, consequently this item can only be replaced one way.

32—L538/539 REAR DIRECTION INDICATOR LAMPS

(Right-hand Drive Models only)

Bulb Replacement

Press the rim and lens assembly inwards and turn it anti-clockwise to release. The bulb is a bayonet fit in the holder and is a single filament No. 382 12v. 21w.

33—L551 STOP TAIL LAMP UNIT

Bulb Replacement

Press the rim and lens assembly inwards and turn in an anti-clockwise direction to release. The bulb is a bayonet fit in the holder and is non-reversible by virtue of offset pins in the cap.

The unit employs a double filament bulb No. 12v.21/6w.

34—REAR NUMBER ILLUMINATING LAMP

Sparto No. 5832

The lens is removed from lamp body by undoing the two fixing screws. Replace defective bulb with 12v. 6w. Festoon No. 254 (Cartridge type).

FILE NOT TO BE REDISTRIBUTED FOR PROFIT ORIGINAL COPYRIGHT HOLDER LOTUS CARS LIMITED 1966

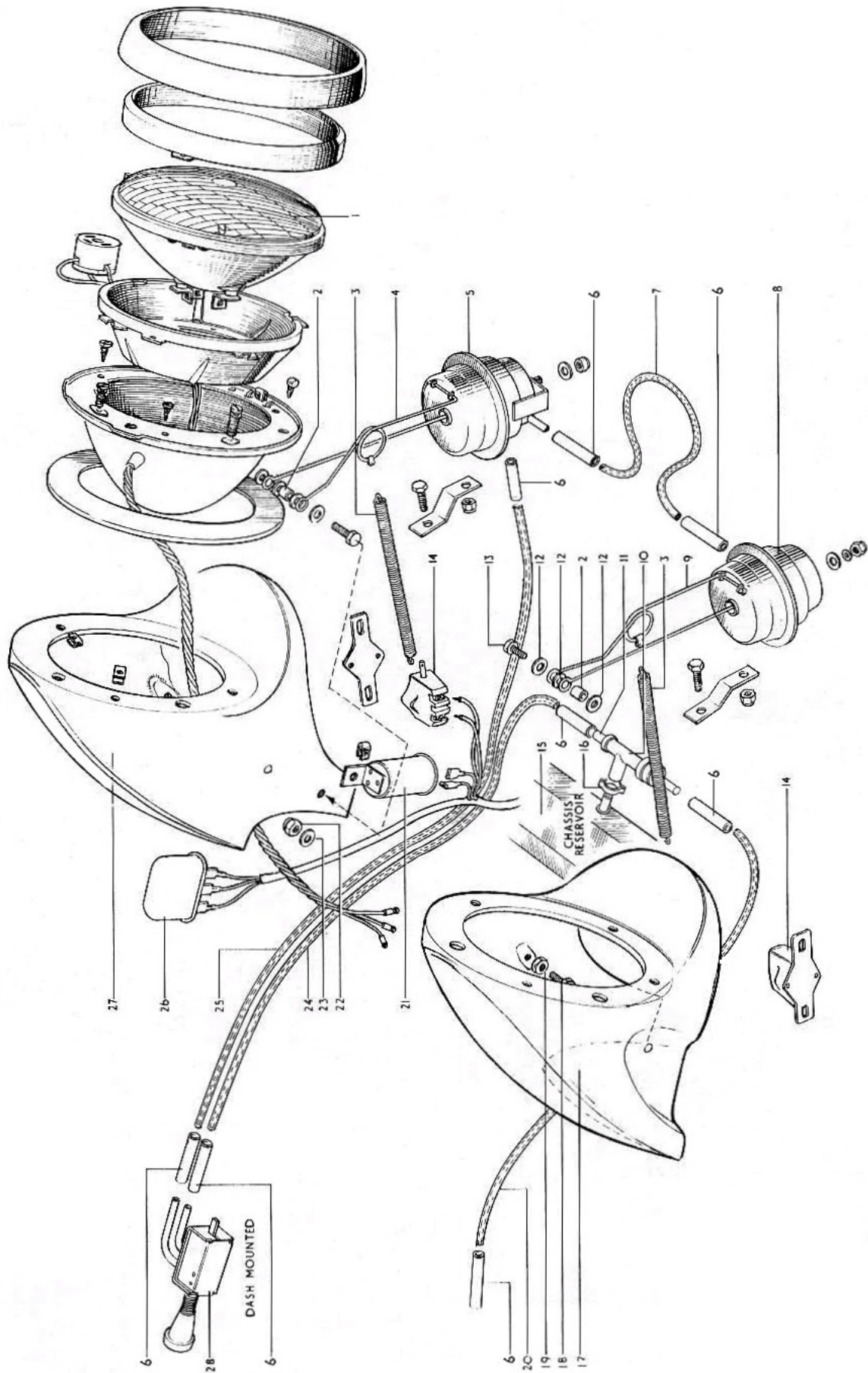

Fig. 36—HEADLAMP MECHANISM

KEY TO HEADLAMP MECHANISM

Key No.	Description	Key No.	Description
1	Headlamp type 700 Mk. X R.H.D. Home (Lucas)	13	$\frac{1}{4}$ in. U.N.F. x 1 in. long bolt
1	Headlamp type 700 Mk. VI U.S.A. and Canada	14	Headlamp contact switch including "P" clip
1	Headlamp type 700 Mk. VI Europe	15	Vacuum reservoir
1	Headlamp type 700 Mk. VI France	16	$\frac{5}{16}$ in. "O" clip (early models only)
1	Headlamp type 700 Mk. VI L.H.D.	17	Headlamp bowl moulding R.H.
1	Headlamp type 700 Mk. VI Sweden	18	Bolt headlamp bowl pivot
2	Distance tube	19	Lock nut
3	Spring (Terry)	20	Pipe nylon $\frac{1}{8}$ in. o.d. x 1 ft. 8 in. long
4	Headlamp return spring L.H.	21	Flasher unit
5	Vacuum cylinder L.H.	22	$\frac{1}{4}$ in. U.N.F. Nyloc nut
6	Sleeve	23	$\frac{1}{4}$ in. plain washer
7	Pipe nylon $\frac{1}{8}$ in. o.d. x 2 ft. 7 in. long.	24	Pipe nylon $\frac{1}{8}$ in. o.d. x 5 ft. 2 in. long
8	Vacuum cylinder R.H.	25	Pipe nylon $\frac{1}{8}$ in. o.d. x 4 ft. 9 in. long
9	Headlamp return spring R.H.	26	Control unit
10	Teepiece non-return valve	27	Headlamp bowl moulding L.H.
11	Adapter	28	Headlamp operating switch assembly
12	$\frac{3}{8}$ in. plain washers		

35—INTERIOR AND INSTRUMENT LIGHTING

Interior Lamp (Sparto No. 5832)

The fascia mounted interior lamp can be removed by undoing the two screws. Replace defective bulb with 12v. 6w. Festoon No. 254 (Cartridge type).

36—INSTRUMENT LIGHTS

Two instrument lights are fitted to the rear of the Lotus Elan fascia, one being mounted on the side of the water temperature/oil pressure gauge, and the other on the side of the fuel contents gauge.

To replace a defective bulb on the fuel contents gauge unit it is advisable to withdraw the tachometer from the fascia, access to the bulb being gained through the aperture on the panel. Unscrew the two knurled tachometer clamping nuts, remove the two spring washers and earthing wires. Simply pull the bulb holder forwards from the rear of the fascia and replace defective bulb with a similar screw-in 12v.2·2w. type.† The bulb similarly mounted on the water/temperature/oil pressure gauge, is of identical type.

High beam indicator light—Mounted on rear of tachometer.

Ignition warning indicator light—Mounted on rear of tachometer.

Flasher unit indicator light—Mounted on rear of speedometer.

The above bulbs are 12v. 2·2w. type screw-in fixing and the bulb holders are again a push fit into the rear of each instrument.

† NOTE: Occasionally it will be found necessary to remove dip-switch cover from steering column before tachometer can be removed.

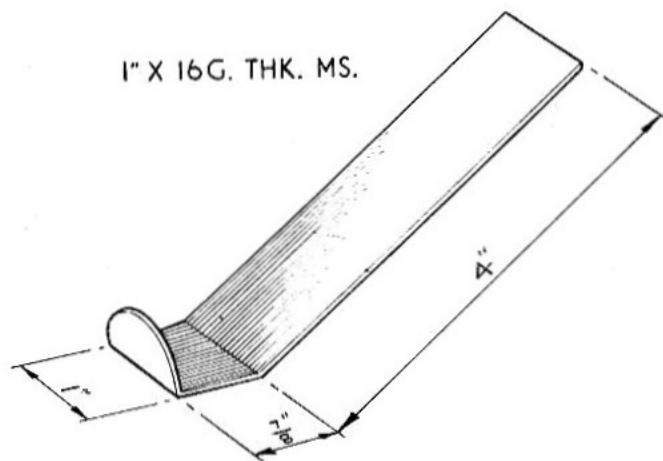

Fig. 37 Lamp Rim Removal Tool

KEY TO STEERING AND DASH ASSEMBLY COMPONENTS

Key No.	Description	Key No.	Description
1	Steering wheel	36	Ignition starter switch
2	Horn push badge	37	Wiper and washer switch (combined)
3	Nut (steering wheel boss retainer)	38	Cable (choke control)
4	Brush (horn push assembly)	39	Headlamp control
5	Clip	40	Instrument panel fixing angle
6	Steering wheel boss	41	Lighting switch (L)
7	Steering wheel clamping ring	42	Windscreen washer kit (Tudor)
8	Bolt 2 B.A. x 1 1/8 in. long	43	Support bracket (windscreen washer kit)
	Plain washer	44	Support bracket (steering column)
9	Spring washer	45	Felt strip (support bracket)
	Escutcheon (trafficator)	46	Clamp (support bracket steering column) (lower)
10	Trafficator switch (on column)	47	Felt strip (support bracket)
11	Steering column cowl assembly	48	Steering column (lower)
12	Cable (slip ring and insulating assembly)	49	Clamp (steering column lower half)
13	Slip ring and insulator	50	Spring (steering column clamp)
14	Screw escutcheons to steering column cowl	51	Clamp—steering column upper to dash panel
15	Nut spire speed	52	Locknut
16	Bearing assembly (steering column)	53	Locating screw
17	Main dip switch (on column)	54	Plate locating (clamp to steering column)
18	Escutcheon (dip switch)	55	Clamp (steering column)
19	Gauge (water temp./oil pressure) assembly	56	Flasher unit (indicator)
20	Oil gauge pipe adapter 1/8 in. B.S.P. x 1/8 in. Briggs	57	Steering column (upper)
21	Oil gauge pipe	58	Instrument panel L.H.D.
22	Speedometer m.p.h. assembly	59	Harness assembly cover (steering column)
23	Instrument fixing strap and lampholder bracket	60	Handbrake cable
24	Lampholder	61	Grommet bulkhead/handbrake cable
25	Tachometer (electronic) assembly	62	Clutch brake and throttle assembly
26	Gauge (Fuel) assembly	63	Rubber clutch pedal
27	Lampholder	64	Rubber brake pedal
28	Cable (bonnet release) assembly	65	Spacing washer
29	Interior light	66	Bearing bracket
30	Cigar lighter (Magnatex)	67	Washer square
31	Facia claylastic trim (satin finish x 34 in. long)	68	Handbrake ratchet tube assembly
32	Panel pin (trim to dashboard)	69	Spire clip
33	Heater switch	70	Spring (pedal retracting)
34	Panel light switch	71	Packing plate
35	Interior light switch	72	Throttle pedal adjusting stop

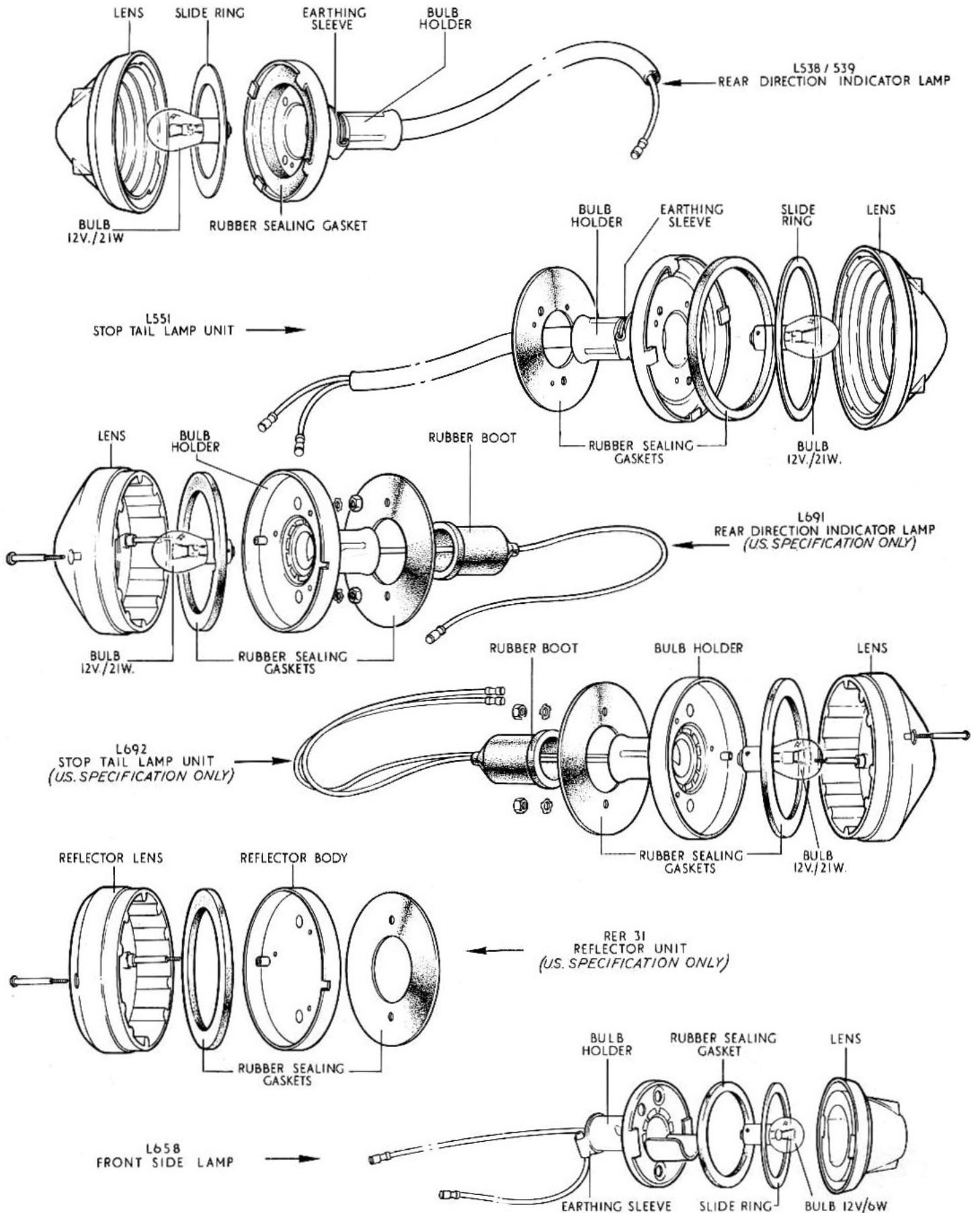

Fig. 39—SIDE AND REAR LIGHTS—LOTUS ELAN

FILE NOT TO BE REDISTRIBUTED FOR PROFIT ORIGINAL COPYRIGHT HOLDER LOTUS CARS LIMITED 1966

FILE NOT TO BE REDISTRIBUTED FOR PROFIT ORIGINAL COPYRIGHT HOLDER LOTUS CARS LIMITED 1966

SECTION M

FUEL SYSTEM

	<i>Chapter</i>
The Fuel system—Lotus Elan <i>Illustration</i>	
The Fuel system <i>Key to components</i>	
Fuel pump <i>Illustration</i>	
Fuel pump <i>Key to components</i>	
General description	1
Fuel pump	2
Removal of petrol tank	3
Air cleaner	4
Weber carburettors	5
Tuning the 40 D.C.O.E. 18 carburettors	6
Levelling the float	7
Flexible carburettor mountings	8
Weber 40 D.C.O.E. 18 carburettor <i>Illustration</i>	
Weber 40 D.C.O.E. 18 carburettor <i>Key to components</i>	

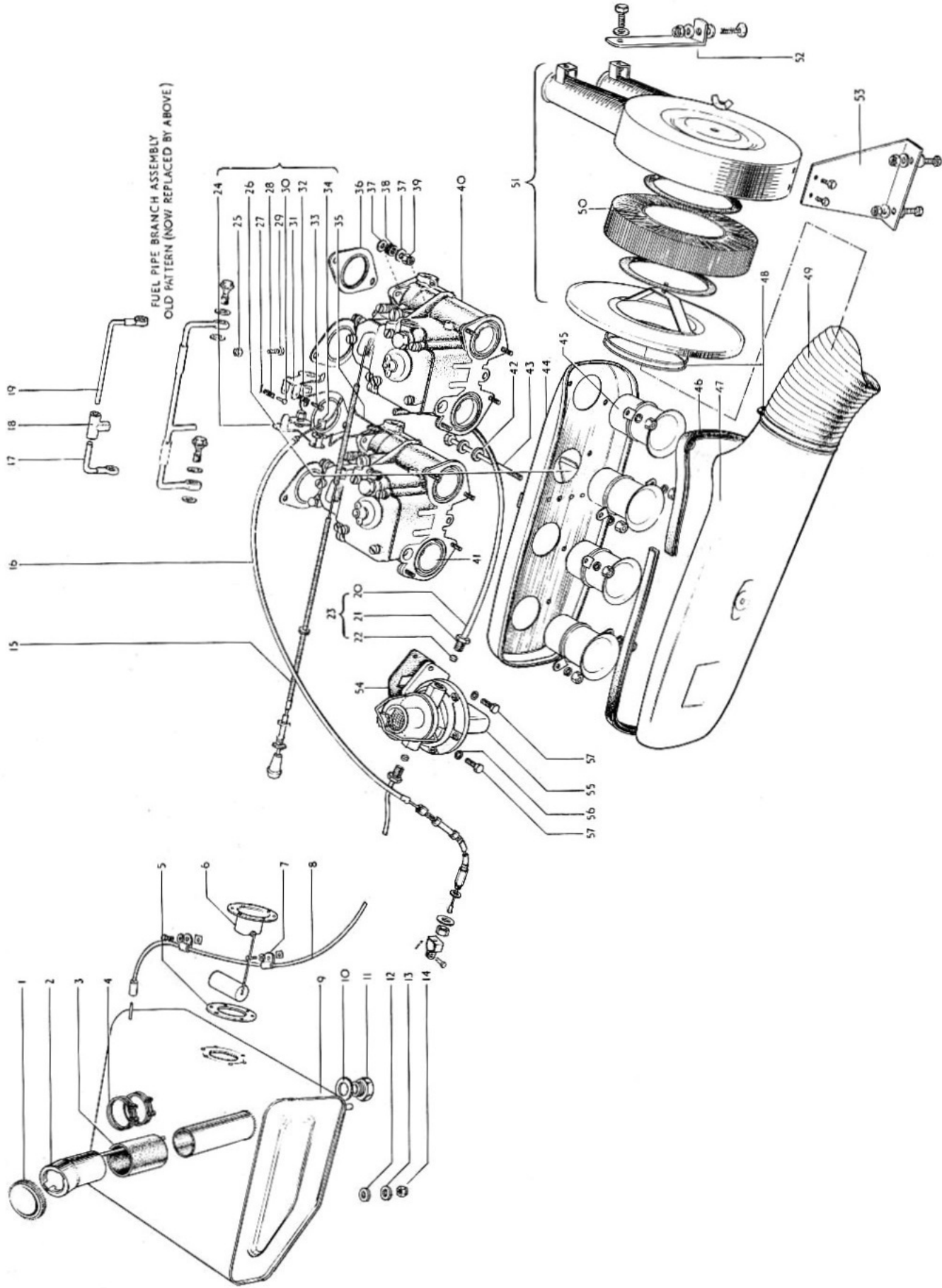
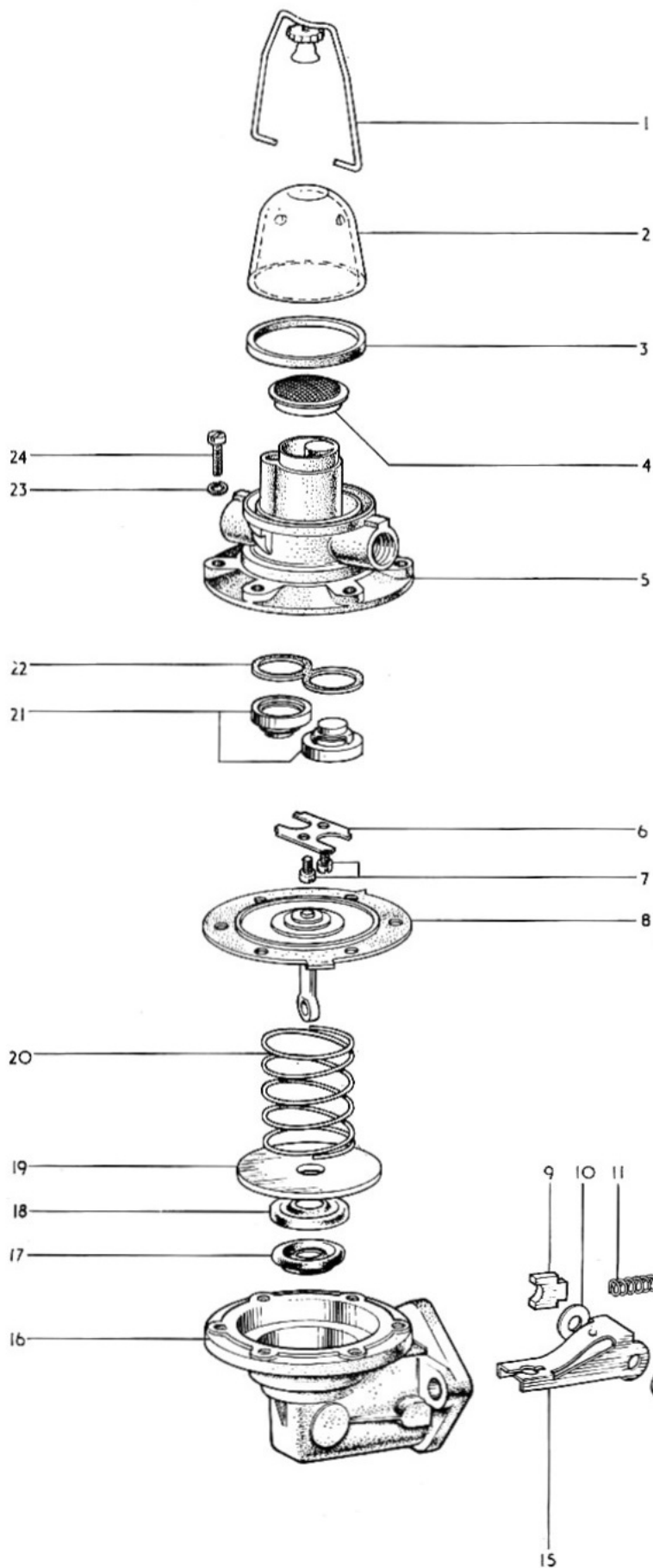

Fig. 1—FUEL SYSTEM

KEY TO FUEL SYSTEM COMPONENTS

Key No.	Description	Key No.	Description
1	Filler cap	30	Pin
2	Filler tube	31	Accelerator lever (front carburettor)
3	Hose 2 $\frac{3}{4}$ in. bore x 2 $\frac{1}{2}$ in. long	32	Spring
4	Hose clips 2 $\frac{3}{8}$ in. i.d.	33	Screw
5	Gasket (gauge unit)	34	Barrel (accelerator lever)
6	Gauge unit	35	Spring (throttle return)
7	"P" clip (spire) (fuel line retaining)	36	Carburettor (gasket to cylinder head)
8	Fuel line complete (tank to petrol pump)	37	$\frac{1}{16}$ in. washer (carburettor mounting)
9	Fuel tank assembly	38	Thackery washer
10	$\frac{1}{4}$ in. B.S.P. fibre washer	39	$\frac{1}{16}$ in. U.N.F. nut Nyloc type "T" (carburettor stud)
11	$\frac{1}{4}$ in. B.S.P. drain plug	40	Carburettor "A" type (front) Weber 40 D.C.O.E./18 assembly
12	$\frac{1}{4}$ in. i.d. rubber washer (fuel tank to body)	41	Carburettor "P" type (rear) Weber 40 D.C.O.E./18 assy.
13	$\frac{1}{4}$ in. i.d. plain washer (special) (fuel tank to body)	42	Washer $\frac{1}{16}$ in. plain
14	$\frac{1}{4}$ in. Nyloc nut	43	Bolt (air box clamping)
15	Control assembly (carburettor choke)	44	Back plate (air box)
16	Control assembly (carburettor throttle)	45	Trumpet (carburettor)
17	Fuel pipe branch rear branch	46	Sealing gasket (air box)
18	"Tee" piece	47	Air box
19	Fuel pipe (front branch)	48	Hose clips (flexible hose air box) 3 $\frac{1}{2}$ in. i.d.
20	Fuel pipe (pump to branch)	49	Hose flexible (air box to air cleaner) 3 $\frac{1}{2}$ in. i.d.
21	Olive $\frac{1}{16}$ in. bore	50	Element (air cleaner)
22	$\frac{1}{2}$ in. — 20 U.N.F. x $\frac{1}{16}$ in. bore male sleeve unit	51	Air cleaner assembly
23	Fuel pipe assembly compressing (pts. 17—23 inclusive)	52	Mounting brackets (air cleaner trumpets)
24	Accelerator lever (rear carburettor)	53	Mounting bracket (air cleaner body)
25	Nut $\frac{1}{4}$ in. Nyloc type "T"	54	Gasket (fuel pump to cylinder block)
26	Bracket (accelerator shaft support manifold)	55	Fuel pump
26	Accelerator lever (front carburettor)	56	Spring washer
27	Split pin	57	Bolt (fuel pump to cylinder block)
28	Spring	58	Throttle pedal
29	Bolt $\frac{1}{4}$ in. x $\frac{3}{4}$ in. long		

FILE NOT TO BE REDISTRIBUTED FOR PROFIT ORIGINAL COPYRIGHT HOLDER LOTUS CARS LIMITED 1966



Key No.	Description
1	Clamp (fuel pump filter bowl) assembly
2	Bowl (fuel pump filter)
3	Gasket (fuel pump filter bowl)
4	Screen (fuel pump) assembly
5	Body (fuel pump) upper
6	Retainer (fuel pump valves to upper body)
7	Screw (retainer to body)
8	Diaphragm (fuel pump) to pull rod assy.
9	Retainer (fuel pump rocker arm pin)
10	Washer (fuel pump rocker arm)
11	Spring (fuel pump rocker arm)
12	Arm (fuel pump rocker)
13	Gasket (fuel pump to cylinder block)
14	Pin (fuel pump rocker arm)
15	Link (fuel pump) assembly
16	Body (fuel pump) lower
17	Seal (fuel pump oil)
18	Retainer (fuel pump oil seal)
19	Washer (fuel pump pull rod oil seal)
20	Spring (fuel pump diaphragm)
21	Valve (fuel pump) caged type
22	Gasket (fuel pump valves to body)
23	Lockwasher
24	Screw (upper to lower body)

FUEL PUMP COMPONENTS

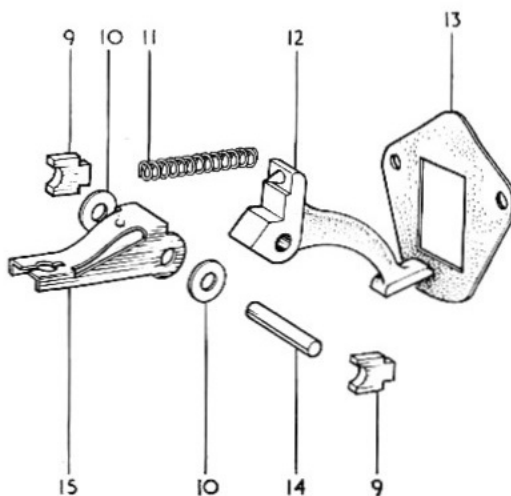

1—GENERAL DESCRIPTION

The Lotus Elan is fitted with an A.C. mechanical fuel pump, supplying 90—100 octane fuel to twin 40 D.C.O.E. Weber carburettors. A 10 gallon (45 litres) capacity metal fuel tank is fitted in the boot of the vehicle accessible via a removable floor. A screw-on bayonet fixing filler cap is located on the right-hand side of the body, forward of the boot lid. The fuel gauge on the instrument panel is operated by a float unit set into the front of the fuel tank. Fuel lines are in flexible plastic from tank to fuel pump and pump to carburettors. The air cleaner, mounted in front of the radiator is of the replaceable paper element type and conducts air via flexible tubing to an (air) mounted over the carburettor trumpets.

Routine maintenance described elsewhere in this section consists of the following:

Every 12,000 miles (19,200 km.) the paper element in the air cleaner should be renewed.

Every 6,000 miles (9,600 km.) clean gauge filter and sediment chamber in the fuel pump.

Every 1,500 miles (2,400 km.) check the vertical movement of carburettors on their manifolds. Check slow running adjustment on carburettors.

Occasionally oil throttle and choke linkages and controls.

2—FUEL PUMP

Description

Fuel is drawn from the fuel tank by the A.C. Fuel Lift Pump which is secured to the engine block and is driven by an eccentric on the jackshaft.

The A.C. pump consists of two main bodies which clamp a diaphragm between their outer flanges.

The lower body assembly comprises a rocker arm and link, both of which pivot on a pin located in the body; attached to the link is the pull rod incorporated in the diaphragm assembly. To protect the diaphragm from crankshaft oil splash, an oil seal is located at the point in the lower body where the push rod passes through. A return spring is interposed between the undersides of the diaphragm and the lower body, this spring determining the pump output pressure. A further spring is fitted between the rocker arm and the body for the purpose of ensuring that the rocker arm is in constant contact with the eccentric on the jackshaft. The hand priming mechanism (incorporated in some A.C. fuel pumps) is not included in the Elan specification.

Assembled in the upper body are two valve assemblies, one being opened by suction, and the other by pressure, both valves held in position by a common retaining plate secured inside the upper body by two screws.

Both inlet and outlet valve assemblies are identical in construction and are renewable and interchangeable.

Also incorporated in the upper body is a filter gauze which is held in position with a domed glass top cover and gasket, which in turn is held by a centre screw clamping the cover to the upper body.

To Test in Position

With the engine stopped and switched off, the pipe to the carburettor should be disconnected at the carburettor

end, leaving a free outlet from the pump. The engine can then be turned over momentarily whereupon fuel should issue from free outlet, once every two revolutions of the engine.

To Remove the Fuel Pump

1. Disconnect the pipes from the inlet and outlet bosses of the fuel pump. Seal off the ends of the pipes to prevent the ingress of foreign matter.
2. Remove two fuel pump retaining bolts and lock-washers, and withdraw fuel pump and engine pad gasket from engine block.

To Dismantle

1. Before commencing to dismantle, clean exterior of pump and scribe a line across the lower and upper body flanges of the pump for location purposes during re-assembly.
2. Remove domed glass top cover of pump also gasket and filter gauze.
3. Remove the five screws and spring washers securing the lower and upper bodies together and separate the two bodies.
4. Remove the valve plate retainer screws and remove the retainer plate valve assemblies, and gasket from upper body.
5. From the lower body remove the diaphragm and pull rod assembly, first turning the assembly through an angle of 90° in order to free the rod from the link in the rocker arm assembly.

NOTE:—re later pattern pumps. The valve assemblies are "staked" in four positions and it is necessary to relieve this "staking" in order to remove valves.

NOTE: The diaphragm and pull rod are a permanent assembly and no attempt should be made to separate the two parts.

6. Lift out the diaphragm return spring and where fitted, remove oil seal retaining washer and oil seal.
7. Providing that the rocker arm pin is held firmly in the lower body it should not be necessary to remove the rocker arm pin or associated parts unless undue wear is in evidence.

Should it be necessary to remove the rocker arm from body, the following procedure should be adopted: The rocker arm and associate parts are retained by two retainers which are fitted into slots at engine face of castings, the retainers in turn being held by punch indentions at each end of retaining pins.

To remove the rocker arm assembly, hold rocker arm firmly in suitable vice, leaving a gap between casting and vice, and with two flat bars, approximately 12 inches long, insert one in the gap each side of the casting and vice, lever the body away from the rocker arm and pin.

NOTE: Care should be taken that the type of removing bars used are flat to ensure that the body machined face is not damaged.

Inspection and Overhaul

1. Thoroughly wash all parts in clean paraffin, ensuring that valves are cleaned separately if being used again.

2. Check the diaphragm for hardening or cracking and examine the lower extremity of the pull rod, where it connects with the rocker arm link, for wear. Renew the diaphragm assembly if any of these signs are in evidence.
3. Check diaphragm return spring, if corroded or damaged, it should be replaced.
4. Visually check valve assemblies, if any doubt exists, replacement valves should be fitted. The two valves are identical and can be used for either application by inverting their positions.
5. Examine the rocker arm face pad for wear. Slight wear is permissible but should not exceed a depth of .010 in. (.254 mm.).
Check rocker arm pin and link holes for wear, also the underside of link where diaphragm pull rod engages for wear.
Badly worn or damaged parts should be renewed.
Check rocker arm return spring.
6. Discard old oil seal and gaskets.
7. Examine upper and lower bodies for cracks or damage. If either the diaphragm or engine mounting flanges are distorted, these should be lapped to restore their flatness.
Renew if either distortion is excessive.

To Re-assemble

The re-assembly of the rocker arm into the body is as follows : Assemble rocker arm, link and spacing washers onto rocker arm pin, place rocker arm return spring into body and insert rocker arm assembly into body of pump. Ensure that the rocker arm return spring is properly engaged between locating "pips" on casting and rocker arm. Tap two new pin retainers into slots in the body and while holding the retainers hard against the rocker arm, pin punch over the end of the slots with a $\frac{1}{8}$ in. pin punch to prevent retainers working loose.

NOTE : When refitting rocker arm pins, always use new service replacement retainers (coloured copper for identification). These are slightly shorter than the production type to allow for new staking.

Fit new oil seal washer and steel retaining washer into the lower body, if required on the model fuel pump being repaired.

Place the diaphragm return spring in position over oil seal retaining washer.

Place the diaphragm assembly over the spring, with the pull rod downwards, and with the locating tab on the diaphragm at the twelve o'clock position. Press down on the diaphragm at the same time turning the assembly to the left in such a manner that the slot on the pull rod will engage the fork in the link, ultimately turning the assembly a complete quarter of a turn to the left, which will place the pull rod in its correct working position in the link.

This will also permit the matching up of the holes in the diaphragm with those on the pump body flange and the tab will now be at nine o'clock position.

Place the new valve gasket in the upper body round the valve ports. Place valve assembly in inlet port with spring facing outwards. Fit other valve in the outlet port position with spring inside the port.

Refit the valve retainer plate and tighten screws until the tension in the retaining plate is taken up.

NOTE:—re later pattern pumps. When refitting re-stake valve in four positions by using a suitable piece of tubing (No attempt should be made to stake earlier pattern units).

Refit filter gauze in top of upper body, also glass domed cover with new cover gasket. Fit central clamping screw.

The upper and lower bodies can now be fitted together as follows : Push the rocker arm towards the pump body until the diaphragm is level with the body flange.

Place the upper half of the pump body into its correct position by aligning the scribed lines made on the two flanges prior to dismantling.

Replace the five securing screws and spring washers and tighten only until the heads of the screws engage the washers.

Release the push rocker arm away from the pump so as to hold the diaphragm at the top of the stroke and while so held, tighten the body screws diagonally and securely.

IMPORTANT: After assembling in the manner described above, the edges of the diaphragm should be flush with its two clamping flanges.

Any appreciable protrusion of the diaphragm indicates incorrect fitting in which case, special care should be taken in maintaining downward pressure on the rocker arm while the diaphragm screws are finally tightened.

3—REMOVAL OF PETROL TANK

1. Drain tank. The drain plug is located on the front right-hand side underneath the tank and is accessible from the underside of the body.
2. Remove boot floor.
3. Slacken off petrol filler hose clips.
4. Push hose downwards onto tank to clear.
5. Remove leads on petrol gauge tank unit.
6. Disconnect "push on" petrol feed pipe connection on the front of tank.
7. Remove the three securing nuts under boot floor (these are located on the underside of the body).
8. Remove tank.

4—AIR CLEANER

The Lotus Elan is fitted with a replaceable paper element type air cleaner. It is recommended that the element should be changed after 12,000 miles (19,200 km.)

To replace the element it is advisable to reverse the bonnet top. This is effected by merely unclipping the two balance springs on either side of the bonnet top and lifting the bonnet off.

When the wing nut, located on the front of the air cleaner body is undone it will be found that the rear cover can be separated by withdrawing from the rear, there being sufficient room to manipulate the cover over the fan unit.

After the parts are separated the element can be extracted. Remove the sealing rings from the cover and behind the element. Now fit new sealing rings in these positions and insert the element, carefully replacing by a reversal of the procedure outlined above.

5—WEBER CARBURETTORS

General

Twin 40 D.C.O.E. 18 Weber carburettors with 30 mm. chokes are fitted to the Lotus Elan. The sizes of all the calibrated components used in these instruments (including the jets and chokes) have been determined during engine development. It is essential therefore that these remain unaltered for correct operation under normal circumstances. Where a question of abnormal operating conditions exists (i.e. extremes in temperature or atmospheric pressure), reference should be sought from the factory over the particular application.

The standard jet specification provides a maximum road performance compatible with economy and reliability. If there should be any irregular running of the power unit through faulty carburation, and it has been ascertained that the standard specified components listed below are fitted to the instruments, then the faulty running can only be attributed to one or more of the following factors.

- (a) Faulty petrol feed. Disconnect flexible pipe from pump at carburettors or at the unions on the two filter entries, and momentarily turn the engine over on the starter. Check that fuel is being delivered by the pump and that the line from the tank to the pump is also unblocked.

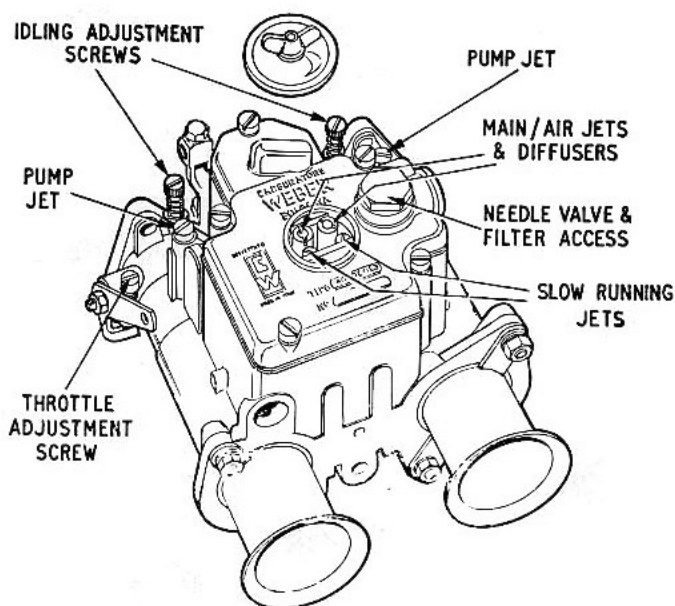

Fig. 3 Jets and adjustment screws

- (b) Blocked filters and jets. Remove the suspected item and wash thoroughly with clean petrol and brush, and/or "blow" clean with an air line.
- (c) Incorrect idling adjustment (see chapter 4)
- (d) Incorrect synchronisation (see chapter 4)
- (e) Incorrect Float level (see chapter 5).

Jet Specification

Three versions of the Lotus Twin Cam power unit are available for the Elan, the first stage being dealt with only in this manual.

Stage I—the standard 105 h.p. unit (suitable for all normal conditions of road use)

Stage II—a 115 h.p. unit using special camshaft and jets, etc., a moderately "tuned" version of the unit for competition.

Stage III—a 140 h.p. unit specially modified by Cosworth for racing conditions only and impracticable for road use.

	Stage I (105 h.p.)	Stage II (115 h.p.)
Choke	30 mm.	32 mm.
Main jet	115	120
Air Corrector Jet	200	180
Pump jet	40	40
Idling jet	45 F9	45 F9
Emulsifying tube	F11	F11

It should also be mentioned that the air trumpets are of special length and cannot therefore be replaced by a standard Weber spare part. Both specifications above take into consideration the normal touring equipment and ancillaries which includes the air box and air filter unit.

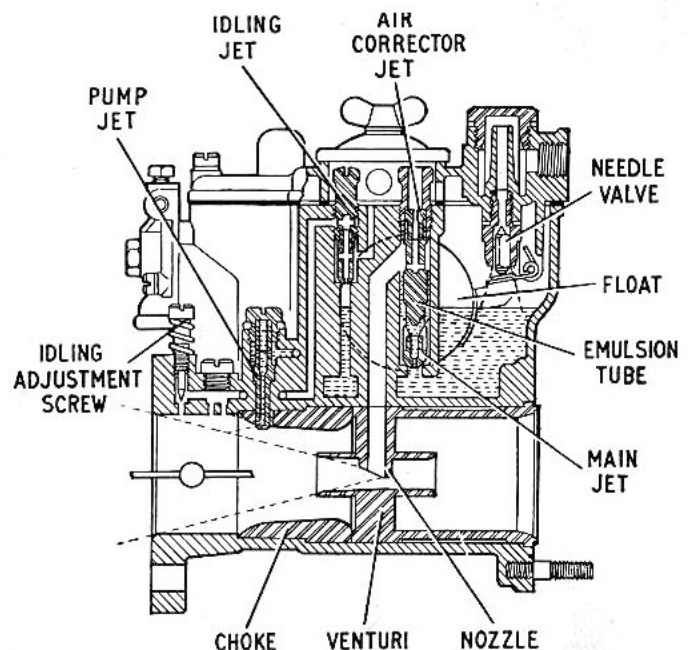

Fig. 4 Section through the Weber Carburettor

Description**(a) Normal Operation (Fig. 4)**

The fuel arrives through the needle valve to the float chamber where the float controls the opening of the needle in order to maintain a constant fuel level. Through the ducts and the main jets it reaches the emulsifying tubes from which after having been mixed with the air coming from the air corrector jets, through the pipes and the nozzles it reaches the carburettor area consisting of the auxiliary venturis and chokes.

(b) Idling Operation and Progressive Action (Fig. 5)

The fuel is carried from the float chamber to the calibrated holes of the idling jets through ducts. It is emulsified with the air also coming from ducts and reaches the idling feed holes which are adjustable by means of screws. The fuel reaches the carburettor throats below the throttle butterflies, and can also reach the throats via progression holes above the butterflies.

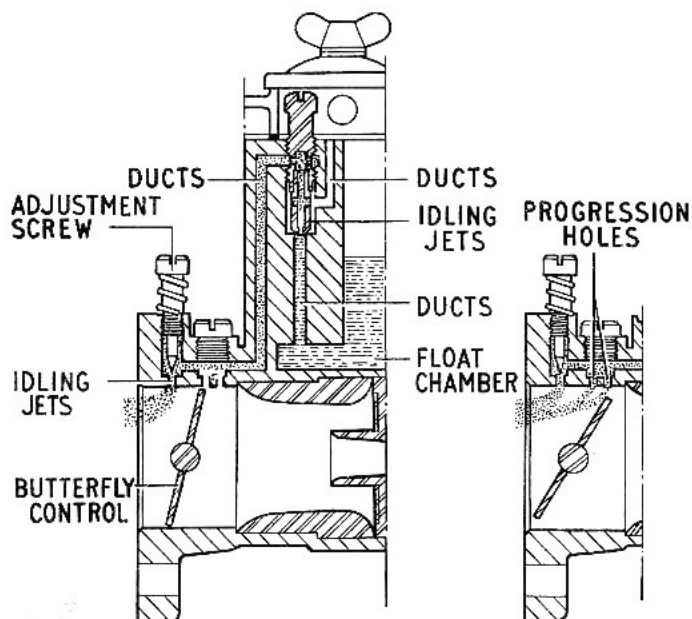

Fig. 5 Idling operation and progressive action

(d) Starting Device (Fig. 7)

The fuel flowing from the float chamber arrives at the starting device through the ducts and starting jets. Emulsified with air coming from a hole in the ducts it reaches the valves where it is further emulsified by air entering from the other holes. It is then carried by means of the ducts to the carburettor throats below the throttle butterflies.

Engine cold starts—starting device inserted—position A

Engine half warm—during engine warming up even if the vehicle is under way, the starting device must be gradually pushed into rest position.

Engine normal running—starting device must be pushed back as soon as ever possible as soon as the engine has reached the operative temperature position C.

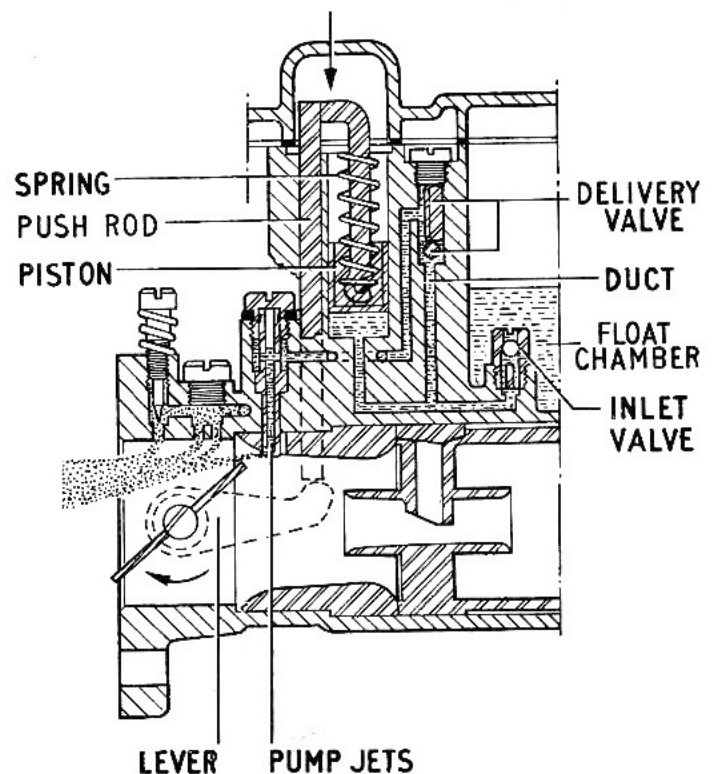

Fig. 6 Acceleration

(c) Acceleration (Fig. 6)

By closing the throttles, the lever actuating the pushrod lifts the piston. The fuel is thus drawn into the pump cylinder from the float chamber through the suction valve. On opening the throttles, the pushrod is pushed in a downwards direction by the return spring. The fuel is injected through the delivery valve to the pump jets by means of the ducts, and thence to the carburettor throats. The inlet valve is provided with a calibrated hole which discharges any excess fuel delivered by the accelerator pump into the float chamber.

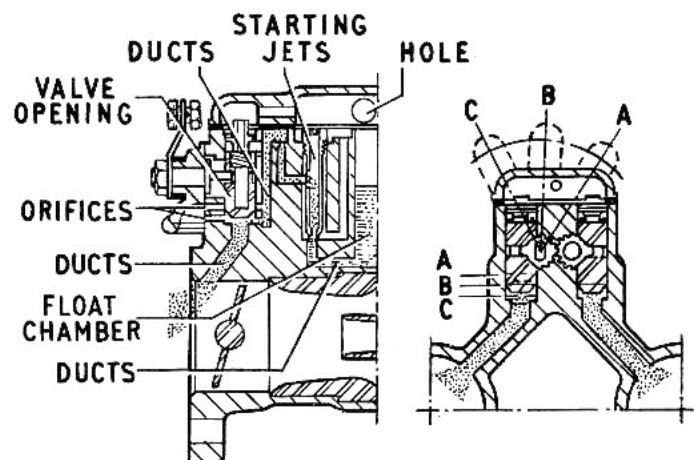

Fig. 7 Starting device

6—TUNING THE 40 D.C.O.E. WEBER CARBURETTORS

There are no mysteries in tuning Weber carburettors. It is not difficult but it cannot be done quickly and a good deal of patience is needed.

In the carburettors fitted to the Lotus twin-cam engine the chokes and jets, etc., are fixed by the manufacturer and the **only** adjustments required are to obtain correct synchronisation and tick-over. These adjustments being affected by the idle speed adjustment screw (or throttle screw), the interconnecting throttle arm screw (or coupling screw) and the four idling mixture volume adjustment screws (or mixture screws).

The carburettors should be "set up" after initial installation or subsequent overhaul as follows :

1. Ensure the engine coolant has reached running temperature and check that the starting control (choke) levers, are fully forward. The warmer the engine oil the easier the adjustment will be.
2. Check that there are no air leaks at the "O" ring gaskets.
3. Unscrew the front carburettor throttle screw (if fitted) two or three turns so that it is inoperative.
4. Set all four mixture screws approximately three-quarters turn open.
5. Adjust the rear carburettor throttle screw to give a tick-over of approximately 1,000 r.p.m.
6. Synchronise the carburettors. This can be done as follows :

(a) Using a proprietary carburettor balancing tool (such as the Crypton "Synchro-Test") adjust the coupling screw until the air flow through each carburettor is the same. Alternatively a piece of rubber or plastic tube can be used; one end being held to the ear and the other at the mouth of the carburettor trumpet. The coupling screw is then adjusted to produce the same loudness of "hiss" at each carburettor.

(b) Short out or remove each plug lead in turn and adjust the coupling screw until the shorting out of each plug produces approximately the same drop in engine revs.

NOTE : For method (a) it is necessary to remove the airbox cover but this will have negligible effect on the carburation at tick-over speeds.

7. Adjust each mixture screw in turn. One at a time, screw each one right in and unscrew a small amount at a time (not more than $\frac{1}{8}$ turn) waiting 5 or so seconds at each setting. A point will be found which will cause a rise in engine revolutions and continued unscrewing beyond that point will cause the revolutions to drop back again. Each screw must be adjusted to give the maximum rise in revolutions. The rise in revolutions may be so small (possibly 50 r.p.m. or so) as to be not detected by ear and consequently it is recommended that a mirror should be hung on the steering wheel so that the revolution counter may be seen.

NOTE : During the course of items 5 and 6 it will be necessary to re-adjust the throttle screw from time to time to maintain the engine revolutions at around 1,000 r.p.m.

8. Repeat 5 and 6 (possibly several times) until no further improvement can be obtained.
9. Adjust the throttle screw to give a tick-over of from 800 r.p.m. if the oil is cold to 1,000 r.p.m. if the oil is very hot after a fast run.

7—LEVELLING THE FLOAT

It is essential that the following directions are complied with in order to obtain a correct levelling of the float.

Ensure that the float A (Fig. 8) is of the correct weight (i.e. 26 gr.), and that it can swing freely about its pivot. Check that the float is free from punctures. Make sure that the needle valve B is tightly screwed in its housing and that the ball pin damper C incorporated in the needle D, is not jammed. Hold the carburettor cover E in a vertical position as indicated in Fig. 8 as the weight of the float could release the ball pin fitted on the needle D. With the float clip in light contact with the ball pin of the needle, the distance of both floats from the flange surface of the carburettor top with the gasket in position, must measure 8.5 mm. After this correct level has been ascertained check that the stroke of the float measures 6.5 mm. If necessary adjust the position of lug H. In case float is not correctly set adjust the position of the float clip until the desired level is obtained. Care must be taken to ensure that the contact face of the clip is not pitted, as this will impair its sliding movement across the needle.

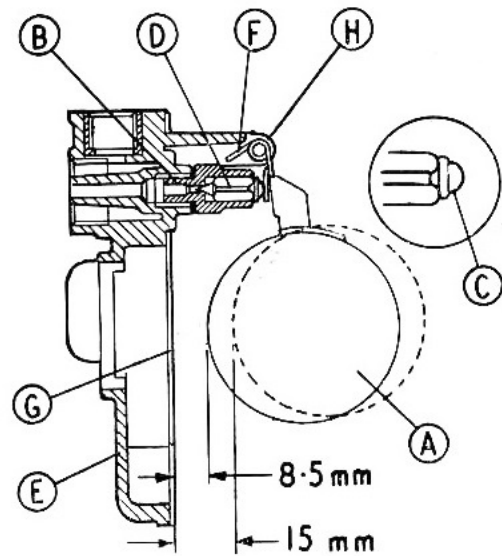
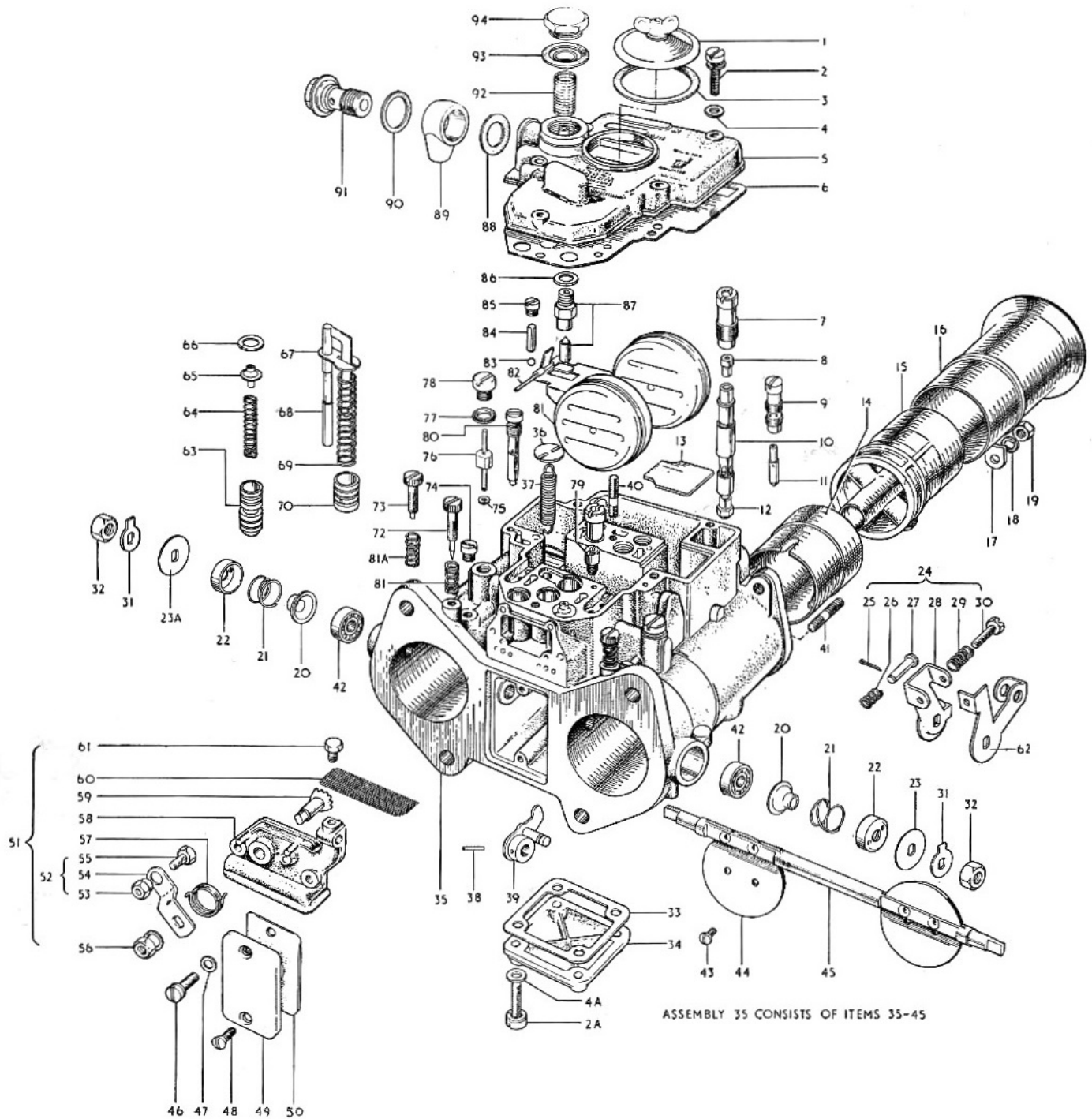

Fig. 8 Levelling the float

8—FLEXIBLE CARBURETTOR MOUNTINGS

To ensure that the rubber "O" ring gaskets between the manifold and carburettor bodies are not flattened, care should be taken to ensure that there is a vertical movement of the carburettor assemblies about their manifolds. This is represented by a total up and down movement of $\frac{1}{8}$ in. at the trumpets, and is achieved by retaining a measurement of .040 in. clearance between the coils of the spring washers at the manifold studs.

FILE NOT TO BE REDISTRIBUTED FOR PROFIT ORIGINAL COPYRIGHT HOLDER LOTUS CARS LIMITED 1966



WEBER 40 D.C.O.E. 18 CARBURETTOR COMPONENTS

KEY TO WEBER 40 D.C.O.E. 18 CARBURETTOR COMPONENTS

FILE NOT TO BE REDISTRIBUTED FOR PROFIT ORIGINAL COPYRIGHT HOLDER LOTUS CARS LIMITED 1966

Key No.	Description	Key No.	Description
1	Jets inspection cover	48	Fixing screw
2	Cover fixing screw	49	Plate
2a	Fixing screw	50	Gasket
3	Gasket	51	Starting control including:
4	Washer for screw	52	Starting control lever complete with
4a	Washer for screw	53	Nut for screw
5	Carburettor cover	54	Starting control lever
6	Gasket for carburettor cover	55	Screw securing wire
7	Emulsifying tube holder	56	Lever fixing nut
8	Air corrector jet 200	57	Lever return spring
9	Idling jet holder	58	Sheath support cover
10	Emulsifying tube F.11	59	Starting shaft
11	Idling jet 45 F.9	60	Strainer
12	Main jet 115	61	Screw securing sheath
13	Plate	62	Throttles control lever (rear carburettor)
14	Choke 30 mm.	63	Starting valve
15	Auxiliary venturi	64	Spring for valve
16	Trumpet (special length)	65	Spring guide and retainer
17	Clamp (trumpet)	66	Circlip
18	Spring washer (trumpet clamp)	67	Spring retainer plate
19	Nut (trumpet clamp)	68	Pump control rod
20	Dust cover	69	Spring for plunger
21	Spring	70	Pump plunger
22	Small lid for spring retainer	71	Spring for idling mixture adjustment screw
23	Distance washer (rear carburettor)	71a	Spring for throttles adjustment screw (rear carburettor)
23a	Distance washer (front carburettor)		
24	Throttle control lever, complete (front carburettor) including:	72	Idling mixture adjustment screw
25	Split pin	73	Throttles adjustment screw (rear carburettor)
26	Spring	74	Progression holes inspection screw
27	Pin	75	Gasket (pump jet)
28	Throttle control lever	76	Pump jet (size 40)
29	Spring	77	Gasket
30	Screw	78	Screw plug
31	Lock washer	79	Inlet valve
32	Fixing nut	80	Starting jet (key number omitted)
33	Gasket	81	Float
34	Float chamber sump cover.	82	Pivot
35	Carburettor body, including :	83	Valve ball
36	Plate for spring	84	Stuffing ball
37	Shaft return spring	85	Screw (stuffing ball)
38	Spring pin	86	Gasket (needle valve seat)
39	Pump control lever	86	Gasket (needle valve seat)
40	Stud bolt	87	Needle valve seat
41	Stud bolt	88	Gasket (fuel filter casing)
42	Ball bearing	89	Fuel filter casing
43	Throttle fixing screw	90	Gasket fuel filter bolt
44	Throttle	91	Fuel filter bolt
45	Throttle shaft	92	Strainer
46	Screw securing support	93	Gasket strainer inspection plug
47	Washer for screw	94	Strainer inspection plug

SECTION N
COOLING SYSTEM

	<i>Chapter</i>
The cooling system <i>Illustration</i>	
The cooling system <i>Key to components</i>	
General description	1
Removing the filler cap	2
Draining the cooling system	3
Filling the cooling system	4
Cold weather precautions	5
Fan belt adjustment	6
Removal and replacement of the radiator	7
Removing the water pump	8

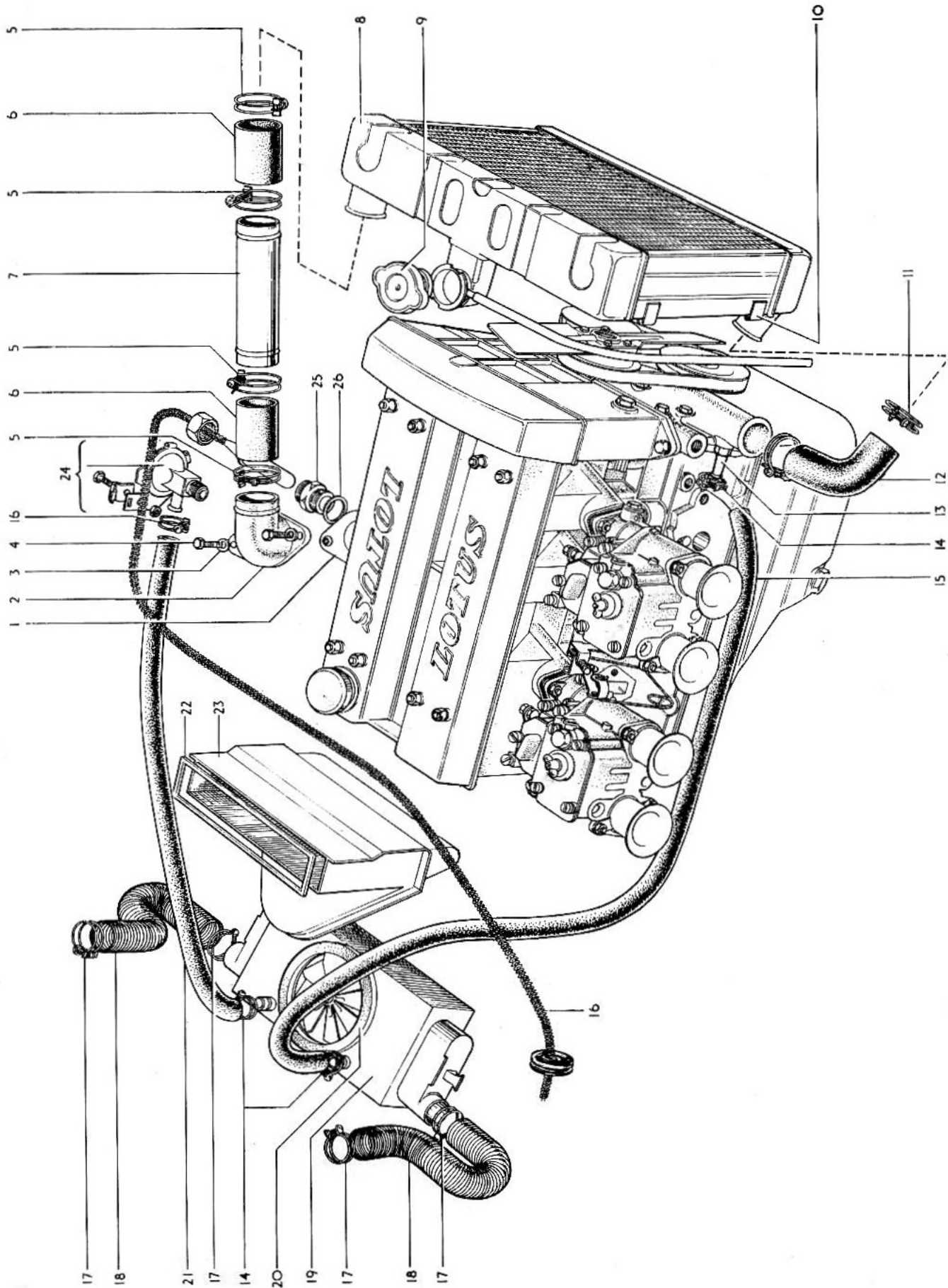

Fig. 1—COOLING SYSTEM

KEY TO COOLING SYSTEM COMPONENTS

Key No.	Description	Key No.	Description
1	Gasket	14	Hose pipe clip
2	Connection (cylinder head water outlet)	15	Water pipe from heater
3	Washer plain $\frac{1}{16}$ in. internal diameter	16	Water temperature gauge including capillary assembly
4	Bolt $\frac{1}{8}$ in. U.N.C. x $\frac{3}{8}$ in. 18	17	Clip (Petroflex) $1\frac{1}{2}$ in.
5	Hose clip (top)	18	Petroflex $1\frac{1}{2}$ in. tube
6	Hose (top) $1\frac{1}{8}$ in. i.d. x $2\frac{1}{2}$ in. long	19	Heater unit assembly including fan and plates and doors
7	Tube (top) water	20	Heater intake seal
8	Radiator	21	Water pipe to heater 18 in. long
9	Radiator cap	22	Sealer x $20\frac{1}{2}$ in. long—(Plenum chamber to body)
10	Clip (spire) side valance to radiator	23	Plenum chamber
11	Hose clip to bottom	24	Heater valve control assembly
12	Hose (bottom)	25	$\frac{3}{8}$ in. B.S.P. male adapter (water temp. take off)
13	$\frac{3}{8}$ in. B.S.P.— $\frac{1}{2}$ in. hose male adapter (water pipe from heater)	26	$\frac{3}{8}$ in. B.S.P. aluminium crush washer

1—GENERAL DESCRIPTION

Cooling water is drawn from the radiator via a rubber hose connection situated at the rear right-hand base tank of the radiator, by the pump driven by belt from crankshaft. After entering the front of the cylinder block from the rear of the pump the coolant circulates round the cylinders and passes to the head. It is returned through the outlet elbow situated at the top left-hand side of the head which incidentally contains the thermostat, to the radiator header tank via the top water hose. The inlet is situated on the rear top left-hand side of the radiator header tank, and water passes from this header tank to the base tank through the core. Air is drawn through the radiator core by a fan attached to the belt driven pump pulley.

2—REMOVING THE FILLER CAP

The cooling system when hot is under appreciable pressure and it must be emphasised that the filler cap be removed very carefully. The filler spout of the radiator is provided with a specially shaped cam to facilitate the operation.

Unscrew the cap slowly until the retaining tongues are felt to engage the small lobes on the end of the filler spout cam and wait until the pressure in the radiator is fully released before finally removing the cap. It is definitely advisable to protect the hand against escaping steam while removing the cap when the system is hot.

3—DRAINING THE COOLING SYSTEM

Remove the radiator header tank filler cap. Open the two drain taps. One is fitted in the centre of the base tank of the radiator and accessible through a hole in the under tray. The other is located on the left-hand side of the cylinder block. It is essential to open both drain taps to drain the system carefully for if only the radiator tap is opened a certain amount of water would still remain trapped in the cylinder block, owing to the location of the water pump.

NOTE:—If an anti-freeze mixture is being used it should be drained into a suitable container and carefully preserved for replacement.

4—FILLING THE COOLING SYSTEM

Ensure that the radiator and cylinder block drain taps are closed, and that all loose connections are tight. Fill up the system with the water until it is just below the top of the filler orifice.

When possible rain water should be used for filling the system. It is advisable to replenish the cooling system

with the vehicle standing level or even in a nose up attitude. This will ensure that no air is locked in the top water pipe. When the radiator has been fully topped up and the engine ran from cold it will be observed that approximately $\frac{1}{2}$ pint of water has overflowed from the radiator. This condition is quite normal and it will be appreciated that topping up is entirely unnecessary and to be avoided particularly when any anti-freeze solution is in the system. Constant replenishment and subsequent overflow can only serve to dissipate the effectiveness of any solutions.

5—COLD WEATHER PRECAUTIONS

During the cold weather add the correct quantity of any reputable make of anti-freeze solution to the radiator according to the manufacturers recommendations to give winter protection down to 32° of frost (0°F.) (—18°C.). These solutions range from 15% to 25% of the cooling system depending on the temperatures encountered. It is advisable to use an anti-freeze solution in the car even if the car is stored in a heated garage since with extreme cold air temperatures, it is still possible to freeze the system whilst running due to the rain effect at speed.

The cooling capacity of the vehicle including heater system is 14 Imp pints (16 $\frac{3}{4}$ U.S. pints, 7.95 litres).

6—FAN BELT ADJUSTMENT

The adjustment of the fan belt tension is effected by slackening off slightly the two generator mounting bolts and the adjustment locking bolt. Move the generator towards or away from the engine as necessary until the correct belt tension is obtained. The correct tension is represented by $\frac{1}{2}$ in. free movement of the belt midway between the generator and fan pulley.

Fan Belt Specification

Type	40° Vee
Width	$\frac{3}{8}$ in.
Length (approx.)	29 in.

Tighten the adjustment locking bolt and the generator mounting bolts.

7—REMOVAL AND REPLACEMENT OF THE RADIATOR

Raise the bonnet and remove the two retaining springs, lift off the bonnet. Drain the water from the radiator (chapter 3). Release the clips on the top and the bottom water hoses and detach the hoses from their connections. Undo the two radiator mounting nuts and washers ($\frac{1}{4}$ in. Nyloc situated on the underside of the body shell above the steering rack) lift out the radiator and its mounting rubbers. Replacement of the radiator is a reversal of the procedure above. Care must be taken to reposition the rubbers between the radiator and body shell.

8—REMOVING THE WATER PUMP

The water pump and fan assembly is attached to the front of the timing chest. To remove it is firstly necessary to take out the radiator as outlined in chapter 7. Slacken off the generator and pivot it towards the engine releasing the fan belt tension. Remove the belt. Undo the four $\frac{1}{4}$ in. set bolts and remove the fan blade and its pulley. Undo the bolt, lockwasher and washer and detach the crankshaft pulley using a suitable pair of drawers. Remove the camshaft cover and undo central head bolt in front of timing chest. Undo the two bolts attaching the lugs of the timing chest to the lugs of the head. Undo jubilee clip and remove heater hose from rear of timing chest. Remove the four bolts locating the sump to timing chest, slacken remainder of sump bolts and lower sump sufficiently to clear lower seal on front of crankshaft. Remove timing chain adjuster. Undo the U.N.F. and U.N.C. set bolts and nuts from the timing case. Carefully remove the timing chest ensuring that the gasket between

the head and chest is parted on the chest side. The pump assembly will come away still located in the front of the timing chest. Pull the water pump pulley flange from the pump spindle using a suitable pair of drawers. Remove the wire retaining clip. Extract the pump spindle from the rear of the timing chest cover.

Reassembly is the reversal of the procedure outlined above, it is suggested that new "O" rings be fitted at this juncture. Thoroughly clean joint faces noting that only Hylomar jointing compound is used in reassembling the cover. Care must be exercised in not damaging the cork gasket between chest and head on reassembly.

9—THERMOSTAT

A bellows type thermostat is fitted in the outlet on the left-hand side of the cylinder head. The unit commences to open at 85° to 88.9°C . (185° — 192°F .) and is fully open at 98.9° to 101.7° (210° — 215°F .)

SECTION O**CHASSIS UNIT**

	<i>Chapter</i>
Chassis Unit General Arrangement <i>Illustration</i>	
General description	1
Maintenance	2
Assessment of accidental damage	3
Replacement of chassis unit	4
Chassis service replacement units <i>Illustration</i>	

FILE NOT TO BE REDISTRIBUTED FOR PROFIT ORIGINAL COPYRIGHT HOLDER LOTUS CARS LIMITED 1966

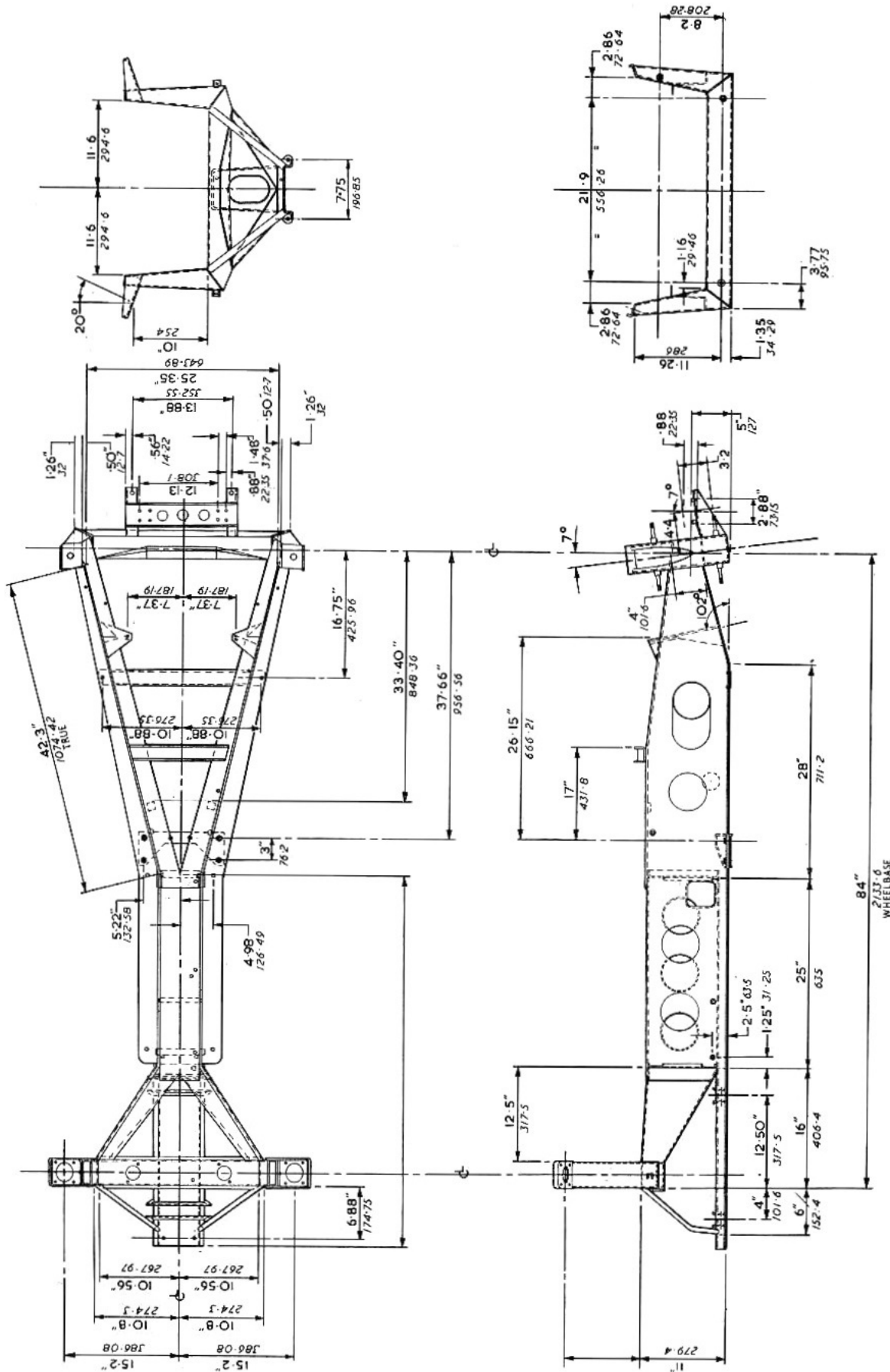

CHASSIS UNIT—GENERAL ARRANGEMENT

1—GENERAL DESCRIPTION

The chassis unit is of the backbone type with a box section spine splayed and braced at front and rear to support the suspension mounting uprights. These mounting uprights are also of fabricated box section in structure and carry the suspension spring/damper top anchorages at their upper extremities. The rear suspension spring/damper units are attached at their upper points by special flexible "Lotocone" mountings. "Welded in" pivot pins provide the mounting points for the front wishbones, whilst the rear wishbones are located within strong steel lugs welded to the chassis.

It should be noted that all the suspension loadings are taken by the chassis, and whilst the chassis unit possesses a great torsional rigidity, the ultimate strength of the vehicle as a whole is dependent on the chassis attachment to its body.

Construction of the unit is generally in 18G (0.048 in.) mild steel sheet with local stiffeners of 16G (0.064 in.) electrically welded, and fully rust-proofed after assembly.

The front cross member serves a dual purpose and acts as the supply reservoir for the operation of the headlamp retraction units.

Both the power unit and final drive units are flexibly mounted within the chassis structure. The power unit is supported by two brackets, each carrying a rubber insulation block situated one each side of the cylinder block. The rear of the unit is supported by a mounting plate also incorporating its insulating block underneath the gearbox and bringing the chassis at this point. The final drive differential assembly is mounted by two cast lugs or ears underneath the rear suspension cross member. Each mounting incorporates a flexible component in rubber, designed to assist in sound and vibration insulation.

2—MAINTENANCE

A minimum of maintenance is required on the chassis unit itself. Occasional checks should be made to see that all body attachments points are tight and that ancillaries attached to the chassis unit is not loose. Checks should also be made to see that the handbrake fulcrum pivot is functioning and an inspection of all suspension attachment points for tightness and ease of operation. Should the rare event occur that the vacuum reservoir be suspected of leakage a check should be made that the take off points themselves are not at fault before resorting to pressure testing the unit.

3—ASSESSMENT OF ACCIDENTAL DAMAGE

Economics, available repair facilities and delivery circumstances provide the criteria for assessment of a chassis repair or replacement. Obviously in cases of minor oblique frontal impacts, where secondary empenages, i.e. radiator mounting brackets, rack and pinion superstructure, etc. are damaged these can be removed straightened and welded back in position. Suspension mountings can be treated in similar manner should the damage be slight. However it is suggested that where a suspension mounting has been badly distorted a replace-

ment be fitted. It is vitally important that alignment and critical dimensions be observed on replacing any unit.

Inspection should be made of engine and gearbox mounting points where a vehicle has been involved in impact. As the unit may have travelled forward, distortion may have occurred, and a check should be made for broken welds, etc.

Reference should be made to the critical dimensions shown on the general arrangement drawing (fig. 1) for a complete damage assessment where any impact has occurred. Diagonal checks from four points will show any mis-alignment.

Where broadside impacts or fire have created severe distortion conditions a replacement unit is essential.

Patching as a repair expedient is not recommended, whilst stretching can only be achieved with heat on the buckled surfaces of larger sections.

4—REPLACEMENT OF CHASSIS UNIT

In the event of a complete chassis write off, it will be necessary to fit the replacement unit to a body shell. It may be found that the body shell mounting points may not exactly match the mounting holes on the new chassis flanges. This condition is due to slight contraction of the body materials during its manufacturing and curing processes. Whilst every effort is made to keep the centre dimensions of all the bobbins within reasonable limits, it is recommended that the body be "offered" up to the chassis before any assembly is undertaken. A visual check should be made for any holes that may not align with their respective mounting points in the body shell. These may then be elongated just sufficiently to receive the mounting bolts.

It is suggested that prior to assembling the body unit into the chassis the fitting of certain components at this junction will facilitate assembly. These are listed below:

1. All brake pipes and connections as follows :
5-way union and pipe from union secured to L.H. chassis side member by spot welded clips on unit.
3-way union on rear L.H. of unit.
Pipe from L.H. front brake unit to 5-way union attached to front cross member.
Pipe from 5-way union to master cylinder (left hand drive cars only)
Pipe from 5-way union to front R.H. brake unit connection.
Pipe from 3-way union to rear L.H. brake unit connection across rear cross member.
Pipe from 3-way union to rear R.H. brake unit connection.
2. Fuel pipe—secured to chassis by two "P" clips and self tap screws (one at chassis bridge piece over gearbox unit and one in top of prop. shaft tunnel).
3. Fit "Lotocone" flexible spring damper mountings in top of rear suspension uprights.
4. Fit "Frustacone" flexible differential mountings in top of rear cross member.
5. Rack and pinion unit.
6. Anti-roll bar.
7. Complete suspension units or wishbones.

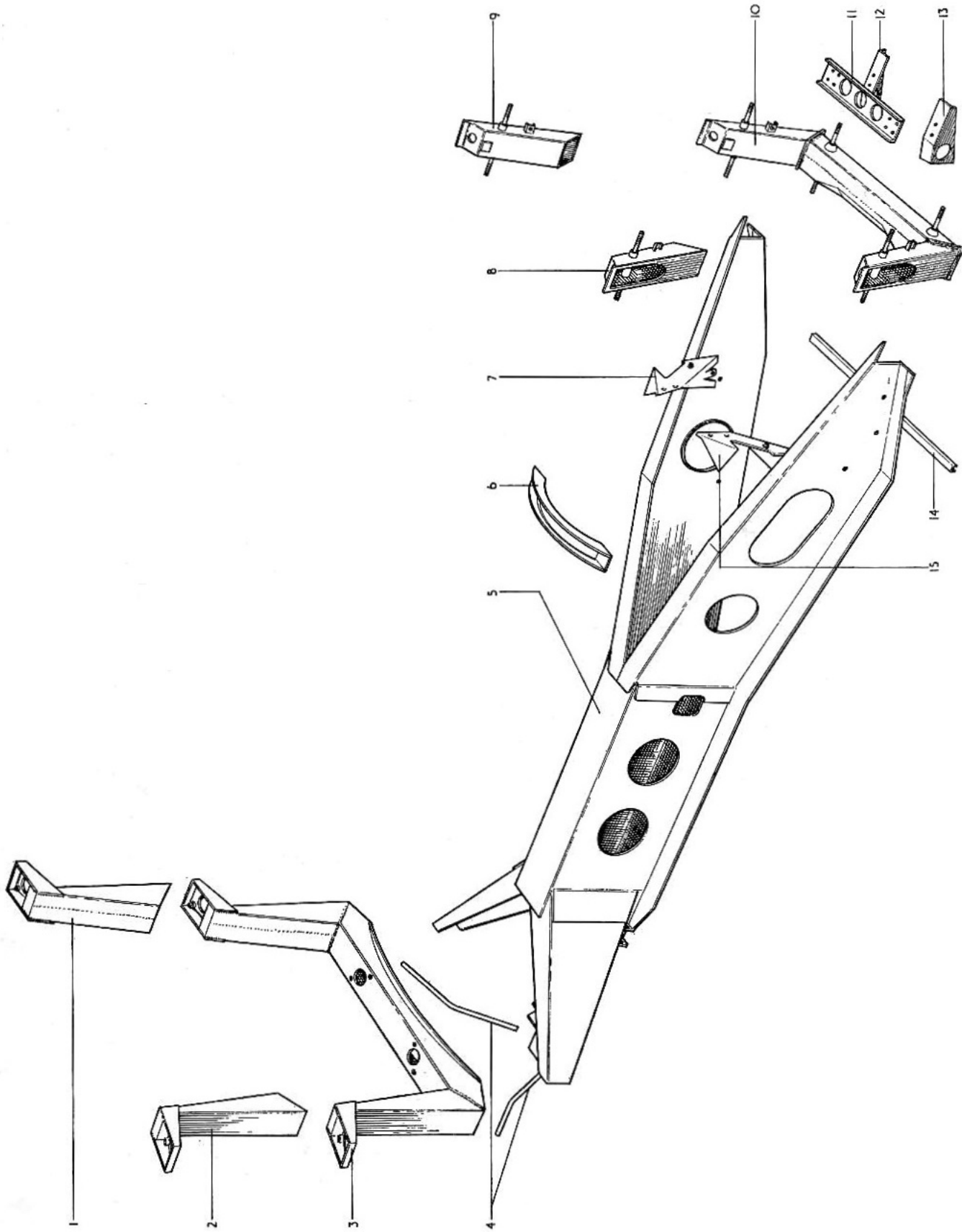

Fig. 2—CHASSIS SERVICE REPLACEMENT UNITS

FILE NOT TO BE REDISTRIBUTED FOR PROFIT ORIGINAL COPYRIGHT HOLDER LOTUS CARS LIMITED 1966

SECTION P

BODY UNIT

	<i>Chapter</i>
Body and trim components <i>Illustration</i>	
Body and trim components <i>Key to components</i>	
Chassis to body attachment points <i>Illustration</i>	
General description	1
Manufacturing process	2
Bonding methods used in manufacture	3
Accident repairs	4
Special repairs critical areas	5
Rectification of minor superficial surface defects	6
Replacement section	7
Damage assessment diagram <i>Illustration</i>	
Metal inserts	8
Body mounting points (special notes)	9

FILE NOT TO BE REDISTRIBUTED FOR PROFIT ORIGINAL COPYRIGHT HOLDER LOTUS CARS LIMITED 1966

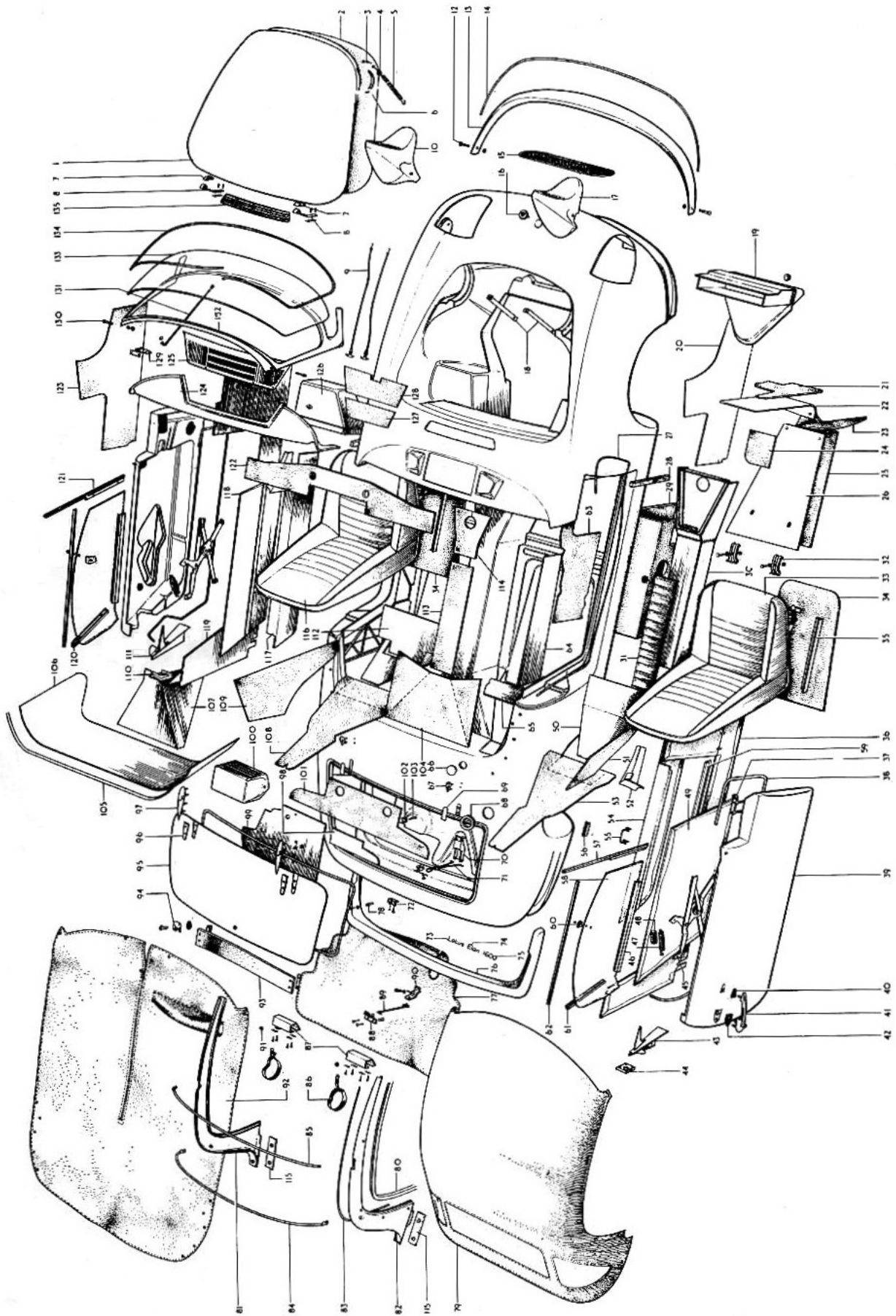

Fig. 1—BODY AND TRIM COMPONENTS

FILE NOT TO BE REDISTRIBUTED FOR PROFIT ORIGINAL COPYRIGHT HOLDER LOTUS CARS LIMITED 1966

KEY TO BODY AND TRIM COMPONENTS

Key No.	Description	Key No.	Description	Key No.	Description
1	Bonnet lid g.f.r.p.	45	Window counterbalance assembly	90	Clip—boot floor
2	Felt under bonnet	46	Mounting channel R.H.	91	Grommet—Hellerman
3	$\frac{3}{4}$ in. U.N.C. bolt x $\frac{3}{8}$ in. long cad. plate—spring to bonnet	47	Spring	92	Tonneau cover L.H.D.
4	Grommet spring loop	48	Rubber sleeve	93	Strap—cant rail stowage
5	Spring-bonnet hinge	49	Door trim assembly R.H.S.	94	Boot lock complete
6	Hinge skid plate	50	Carpet—rear floor—R.H.	95	Boot lid g.f.r.p.
7	Bonnet catch plate	51	Felt—rear wheel arch R.H.S.	96	Gasket—boot hinge rear
8	Bonnet catch spring	52	Trim extension g.f.r.p. to R.H.	97	Boot hinge
9	Cable—bonnet release (see instrument panel)	53	Rear floor slope felt R.H.S.	98	Filler piece—boot floor
10	Headlamp bowl g.f.r.p. L.H.S.	54	Door armrest trim panel assembly R.H.S.	99	Boot floor assembly
11	Body shell—g.f.r.p.	55	Door pull (Hills precision die casting Pt. No. 101)	100	Battery box g.f.r.p.
12	$\frac{3}{16}$ in. B.S.F. x $1\frac{1}{2}$ in. long chromed dome-head coach bolt	56	Ashtray	101	Felt—boot front
13	Front bumper g.f.r.p.	57	Front guide channel assembly R.H.S.	102	Wingnut—spare wheel retainer
14	Clay/astic trim chrome x 6 ft. long	58	Side window glass	103	Stud—spare wheel retainer
15	Radiator intake grilles	59	Kick strip door surround	104	Felt—rear tunnel
16	Badge	60	Finger lift	105	Section No. 172 or 6413 (type 5) Class 3
17	Headlamp bowl g.f.r.p. R.H.S.	61	Rear guide channel assembly R.H.	106	Carpet—rear bulkhead
18	Support bracket—bonnet hinge	62	Exterior weatherstrip mounting channel R.H.	107	Carpet—rear tunnel
19	Plenum chamber (see cooling system)	63	Felt—tunnel side cut-away	108	Felt—rear floor slope L.H.
20	Carpet—front tunnel R.H.	64	Carpet—centre tunnel—R.H.	109	Felt—rear wheel arch L.H.
21	Felt—toeboard R.H.S.	65	Battery recess cover plate	110	Door lock striker L.H.
22	Carpet—footbox R.H.	66	Grommet—rear suspension strut access	111	Door lock and plate assembly
23	Felt—front wheel arch R.H.S.	67	Rear hook—hood fixing	112	Carpet—rear floor
24	Felt—bonnet recess—under R.H.S.	68	Petrol filler grommet	113	Felt—tunnel top—centre
25	Felt—floor carpet R.H.S.	69	Gasket—boot hinge front	114	Felt—tunnel top—front
26	Carpet—front floor R.H.	70	Bracket—boot lid stay	115	Under seat felt R.H.
27	Door edging strip	71	Spring—boot lid stay	116	Assembly of seat L.H.S.
28	Weather seal and stop door	72	Bracket—boot floor support front	117	Door armrest trim panel assembly R.H.
29	Felt—backbone saddle	73	Name plate "Lotus"	118	Door trim panel assembly L.H.S.
30	Tunnel top Royelite moulding	74	Name plate "Elian"	119	Door surround trim panel L.H. R.H.D.
31	Armrest—tunnel top	75	Name plate "1600"	120	Rear guide channel assembly L.H.
32	Seat clamp plate	76	Rear bumper g.f.r.p.	121	Front guide channel assembly—L.H.
33	Assembly of seat R.H.S.	77	Floor mat	122	Felt—bonnet recess
34	Under seat carpet L.H.	78	Stud spire	123	Carpet—front tunnel L.H.
35	Seat runner	79	Hood assembly	124	Instrument panel Royelite crash pad
36	Door surround trim panel R.H. R.H.D.	80	Drip rail section	125	Speaker/demister grill
37	Door hinge arm	81	Cant rail g.f.r.p. L.H.	126	Parcel shelf g.f.r.p. moulding R.H.D.
38	Seal surround on door	82	Cant rail g.f.r.p. R.H.	127	Felt (front tunnel top)
39	Door panels assembly R.H.S.	83	Weatherseal—Dunlop 33 in. long	128	Felt (front tunnel top)
40	Gasket—front-handle to door	84	Hood stick—rear	129	Interior mirror
41	Handle—door exterior	85	Hood stick—front	130	Eye bolt
42	Gasket—rear—handle to door	86	Soft top retaining straps	131	Windscreen tie rod
43	Door lock and plate assembly	87	Lamp guard—rear	132	Windscreen frame g.f.r.p.
44	Door lock striker R.H.	88	Plate—boot support rod	133	Windscreen—laminated glass
		89	Rod—boot support	134	Weatherstrip—Clatonrite (10½ ft. approx.)
				135	Heater intake grill

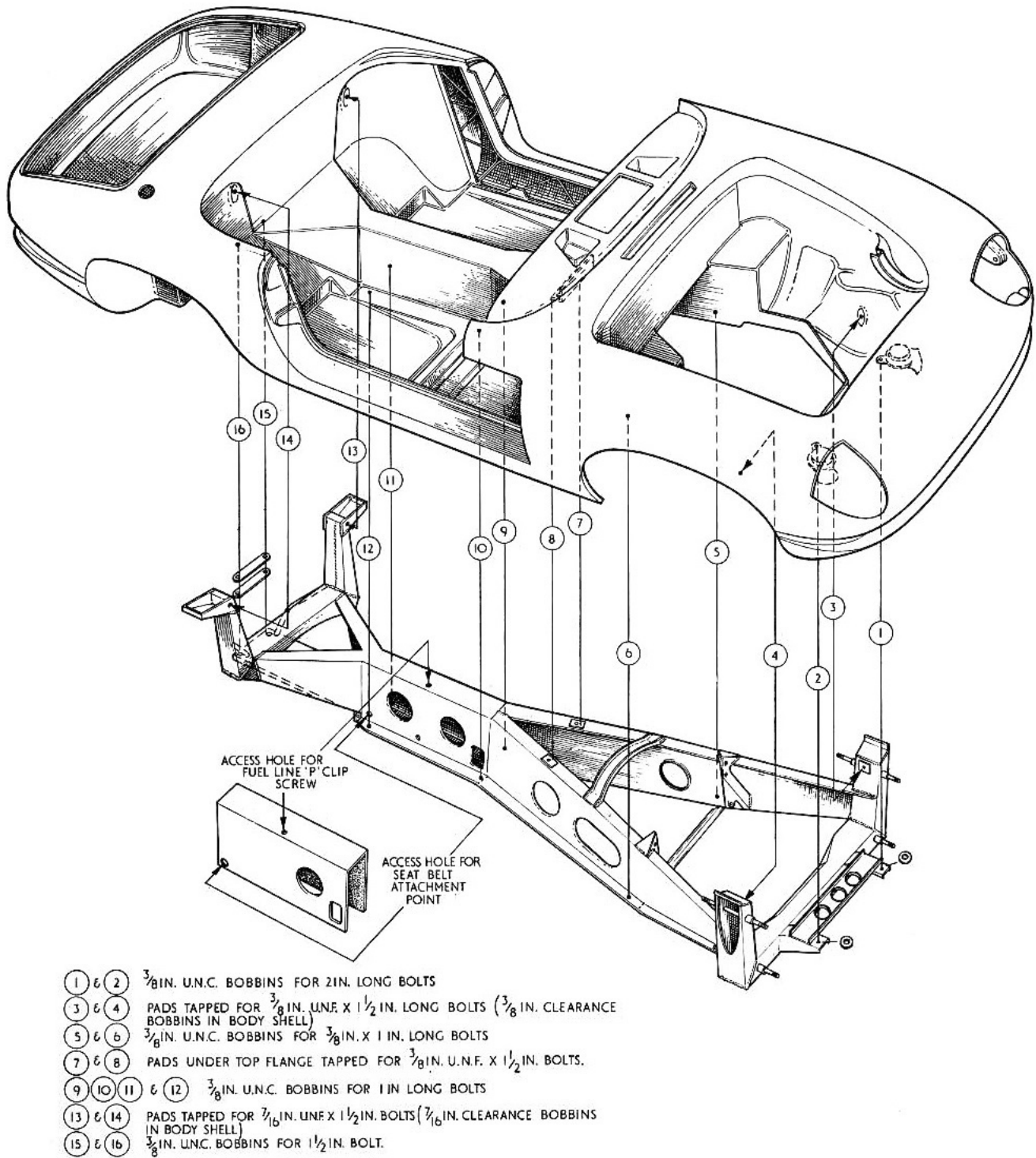

Fig. 2—CHASSIS TO BODY ATTACHMENT POINTS

1—GENERAL DESCRIPTION

As shown in the illustration opposite the basis of the vehicle comprises a one piece moulded glass fibre body shell which straddles a sheet steel backbone chassis being attached to it at the sixteen points indicated.

Whilst the chassis carries all the major structural loads, the body is used to carry or transfer the remainder and when the body and chassis are properly and tightly connected, each contributes to the strength and torsional stiffness of the other.

The body door apertures are reinforced by welded mild steel frames which ensure longitudinal box section to carry the outboard weight of the seats as well as the seat belt loads, pedal mountings, trim panel and wiper motor, etc.

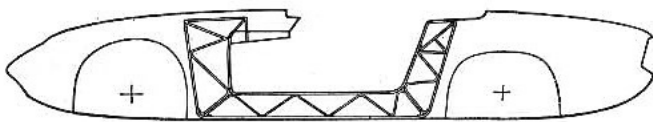

Fig. 3

Construction of the body is generally in laminated 2½ oz. chopped strand mat. A high quality Polyester is used for the layup of all components giving a panel thickness of approx. .125 in. In a few more highly stressed areas e.g. areas around side frames, metal inserts—especially major structural attachment points, seat mountings, floor areas, pedal mountings and wheel arch lips—the thickness is increased up to .250 in. For replacement laminates or repairs any high quality commercial grade Polyester can be used although it should be a type having a reasonably high heat distortion point.

The body shell is laminated basically as an upper and lower moulding but these two components are butt jointed (See Fig. 4) whilst still in the mould and before the shell is fully cured 3 in. wide strips of chopped strand mat are applied over these joints with Polyester resin forming a completely homogenous structure. Polyester resin filler compound is used to fill in imperfections at the seam lines.

The nature of the design of all body panel joints is such that there are no critical or highly stressed bonds or joints in the body shell itself and the major problem in creating all wheel arch and bulkhead joints revolves around the need to obtain a perfectly waterproof or gasproof joint as the case may be.

2—MANUFACTURING PROCESS

(a) General

Construction of the body shell is achieved by the use of two main moulds. The upper mould which contains the basic shape and the lower which contains the under-tray and wheel arches, etc. These two moulds are brought together in the process of the construction of the body unit forming in effect a one piece moulding by lamination at the seams. The illustration (Fig. 4) overleaf shows this process.

The bonding or jointing of all panels and sections is in all cases provided by an adhesive or glueing action, and for this reason the efficiency of the bond is dependent of the following factors.

(b) Surface Preparation

Polyester laminates (notably the "rough side") cure with a "greasy" surface usually caused by air inhibition of the resin. This is best removed by light sanding of the greatest possible area and thereafter swabbing off the dust with acetone. It is of no advantage to rough up with a toothed tool, leaving the surface covered with fibre stubs as these will have no tensile strength at all and combined with loose dust can actually act as a barrier between the bonding resin and the laminate.

When bonding to a moulded surface great care must be taken to remove all parting agents, e.g. wax or P.V.A. (Poly-vinyl-alcohol).

(c) Surface Coverage

As stated in the preceding paragraph it is essential to concentrate on preparing the greatest possible area, but in point of fact it is virtually impossible to achieve 100% bond, particularly when bonding two rough surfaces of the laminates together as the high spots and build ups vary considerably. For this reason the practice is to mix the bonding resin to a toothpaste consistency, apply fairly thickly (approximately ⅛ in. in most cases) and apply sufficient clamping pressure to squeeze as much resin as possible out.

(d) Correctness of Bonding Mix

Care has to be taken to see that the percentages of curing agents or hardeners are very carefully calculated. If this is not done the bonding material may remain elastic or become too brittle, resulting in an inferior bond.

Clamping pressure has to be maintained until the material has set properly. The various types of bond employed in the Lotus Elan are described in the following chapter.

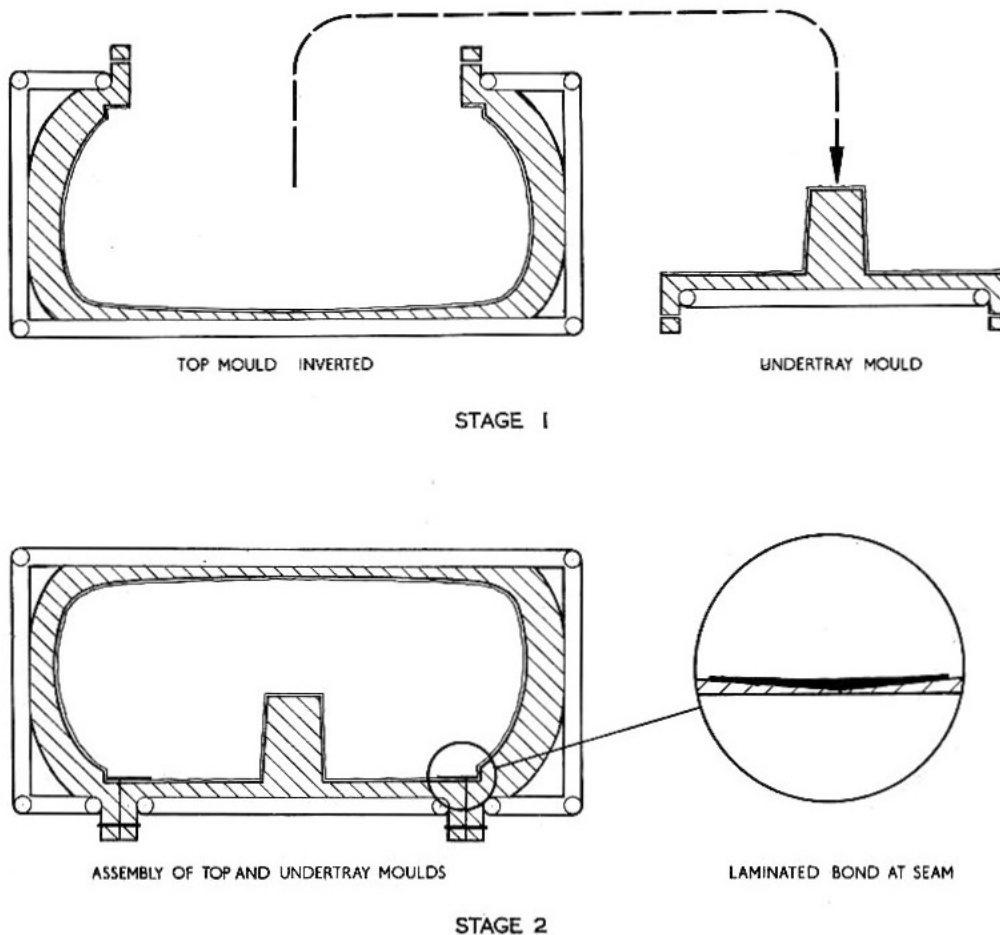

Fig. 4
Manufacturing Process of Body Moulding

3—BONDING METHODS USED IN MANUFACTURE

Typical sections through various body areas are included on these pages to provide the repairer or service engineer with a knowledge of the construction for continuity purposes when repairs are effected by him.

(a) Stressed Bonds

Stressed bonds are invariably in the form of taped joints where one of the intersecting panels is turned forming a reinforcement and successive layers of woven tape are laminated into the angle where the two panels meet. It therefore follows that these require more critical attention. Fig. 5 shows the type of bond used on the sideframes and sills. Fig. 6 shows a section where the body meets the vertical panel of the engine compartment forming the front wheel arch whilst Fig. 7 illustrates in plan form the bonding condition where the front bumper recess meets the front of the wheel arch.

(b) Panel Stiffening

These usually take the form of double skinned areas and Fig. 8 shows a box section incorporating Somrib

paper rope reinforcement which form a cross bracing under the top skin of the nose section. This reinforcement incidentally, has a wire insert running longitudinally in the centre of the rope. Fig. 9 illustrates a box reinforcement where the turn of bonnet lid sides are blanked into a box section by cardboard further covered by a reinforcing skin of fibre glass. Fig. 10 illustrates the condition at the rear scuttle and shows a cross section at this point. A honeycomb sandwich is laminated on the under surface of the rear scuttle stiffening the panel to take the hood and boot hinge loadings.

(c) Semi-wet Bonded Joints

In this system a cured moulding is pressed against the wet layup of another moulding so that the bond is formed as the wet layup cures. Fig. 11 shows this system which is used on boot lids, windscreen frames and plenum chambers.

(d) Wet Bonded Joints

This system is employed only on the doors. Fig. 12 shows how the flanges around the door are clamped together where both laminates are still wet and depicts a section through the door showing outer and inner skins.

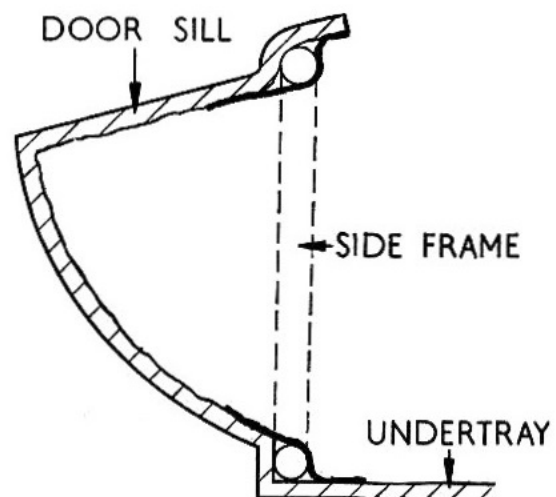

Fig. 5
Side frame bond to undertray and sill.

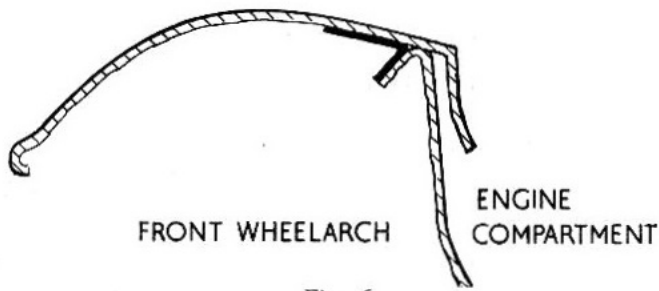

Fig. 6
Laminated taped joint—wheel arch—engine compartment

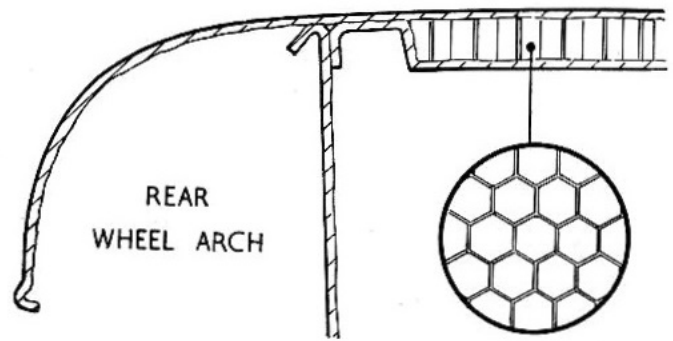

Fig. 10
Honeycomb sandwich reinforcement—rear scuttle

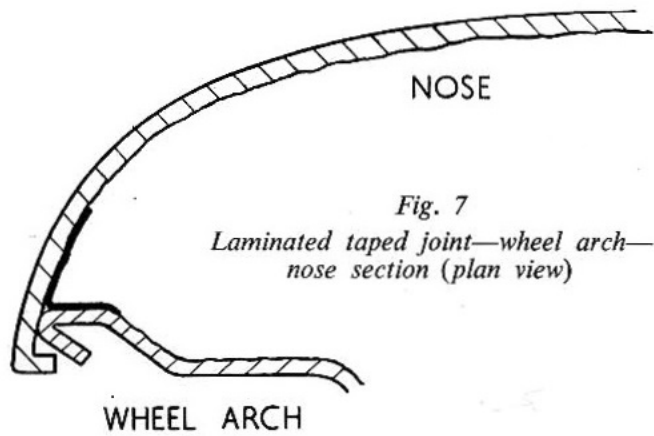
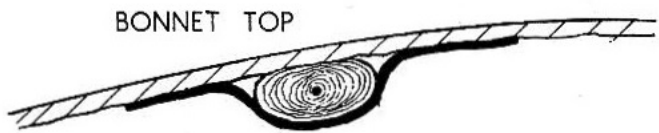

Fig. 7
Laminated taped joint—wheel arch—nose section (plan view)



'SOMRIB' PAPER ROPE
Fig. 8
Somrib reinforcement—bonnet top

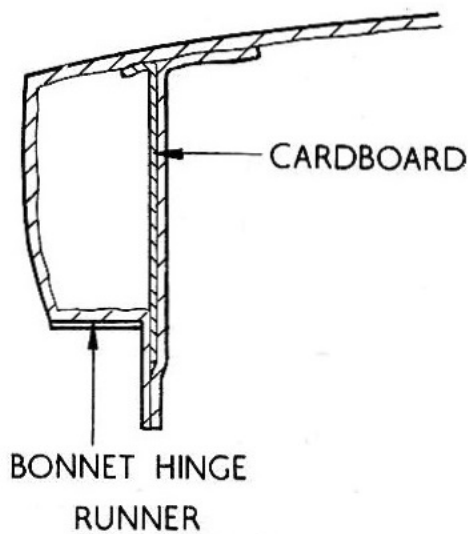

Fig. 9
Box section reinforcement—bonnet top

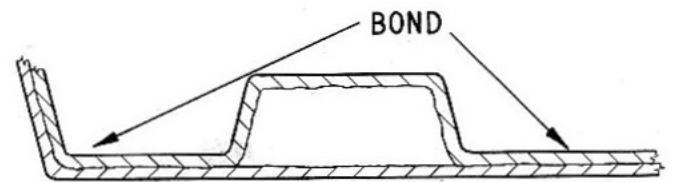

Fig. 11
Semi-wet layup bonds

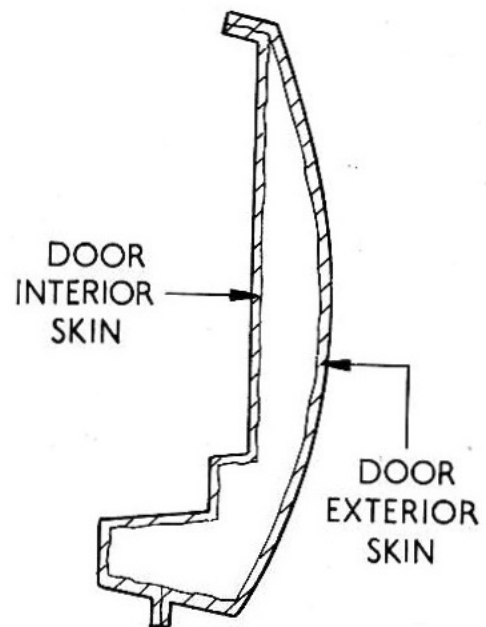

Fig. 12
Wet layup bonds—doors

4—ACCIDENT REPAIRS

(a) Assessing Accident Damage

All body damage may be considered as structural apart perhaps from minor damage to the front and rear extremities, doors, etc.

In order to assess damage it is obviously necessary to study the basic form of construction nature and position of bonds.

As a general rule there should be a bond wherever two panels touch, or wherever they enclose on important points. It is usually possible to check these bonds both visually and physically for fractures or breaks. Ascertain the cause of damage and the direction of impact and examine all panels or bonds which may have been effected. A front end impact for example may easily cause the bonds at the bulkhead to split without the defect being normally visible and so on.

If necessary the metal on other components should be removed to facilitate examination as to the extent of damage sustained.

Before the assessment can be completed it is essential to decide on the repair method to be followed, the sizes of replacement panels to be ordered, etc. as the detailed instructions provided hereafter should be carefully studied.

The extent of the damage (and size of replacement panels) should take into account surface crazing mentioned in section 6.

Fire damage is of the most difficult to assess but generally only the obviously burnt or charred sections will need to be replaced or reinforced.

The pedal mounting areas are heavily loaded and since failure of these in service could be fatal, they should be carefully examined if they have been close to the fire source.

(b) Replacement Panels

Replacement doors, lids and other loose components are available from the manufacturers (Lotus Cars Ltd.) or an official Lotus distributor. These are generally supplied in bare paint finish only as it may be necessary to hand fit and trim the edge, etc.

Where the repair of a damaged body does not call for a replacement section as outlined in chapter 5, repairs using the basic bonds and joints may be made as described in the following chapter.

(c) Basic Bonds and Joints for Repair Work

Simple Fracture or Insertion of New Sectional Laminates

The ideal way to repair a fracture is shown in Fig. 13. The old laminates are tapered off for 3 to 4 in. on each side of the fracture line, a reinforcing layup comprising alternative layers of chopped strand mat and fine woven cloth is applied on both sides of the panel providing a symmetrical repair of great strength.

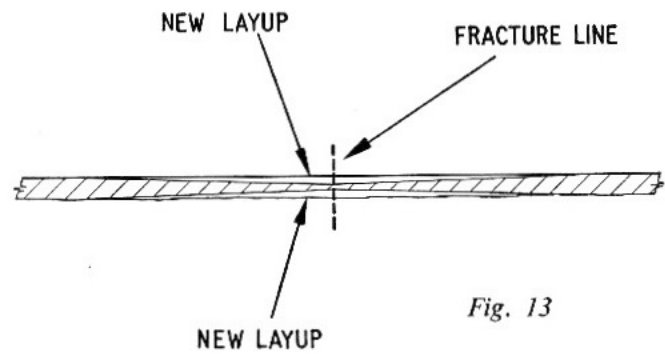

Fig. 13

In most cases it is naturally advisable to make the reinforcing layup on the back side of the panel considerably stronger than that on the outside.

Alternatively: When it is difficult to taper both sides of the laminate an almost equally effective joint can be obtained as shown in Fig. 14 in which the reinforcing layer is done on the back side of the panel.

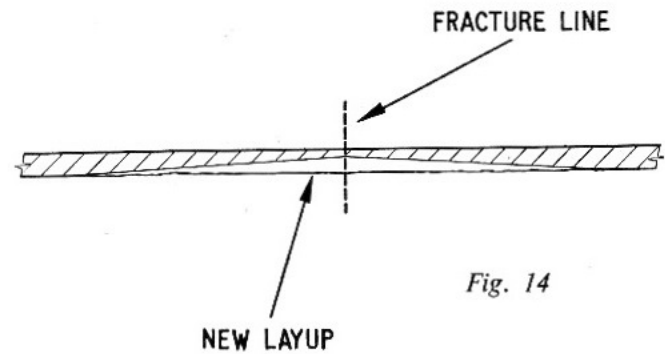

Fig. 14

Alternatively: The method in Fig. 15 is also possible but not very satisfactory as it leaves a latent weakness on the old fracture line. In this system the reinforcing layer is added on the back side, but with no tapering of the old panels and with the crack line of the old panel merely filled in.

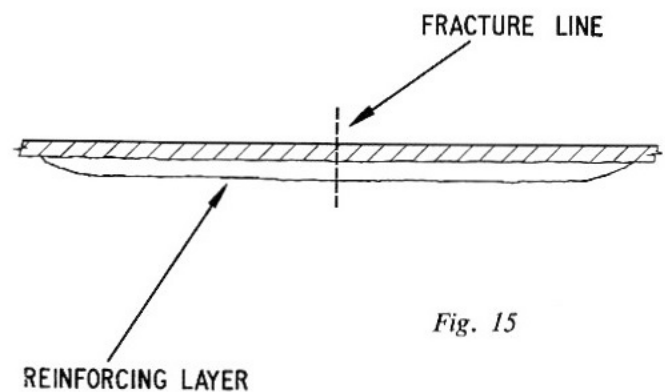

Fig. 15

In such a case (and for that matter with any of the aforementioned jointing systems) it is advisable to laminate a box or channel section over the joint at suitable intervals as shown in Fig. 16 if this can be neatly done.

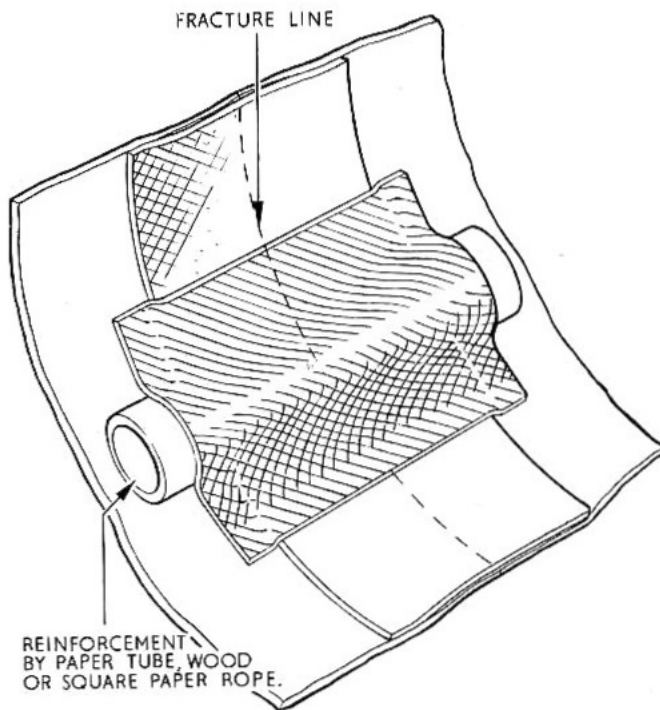

Fig. 16

Box section reinforcement over fracture line.

5—SPECIAL REPAIRS INVOLVING CRITICAL AREAS

(a) Pedal Mountings

Due to the sensitive and non-adjustable setting of the pedals, the panel area on which the pedal assembly is mounted.

In cases of damage at this point it is most essential to position the vertical face of the pedal mountings accurately relative to the bulkhead and cross shaft mounting brackets.

Both the thickness and the smoothness of the internal vertical face of the laminate is important.

A maximum thickness of $\frac{1}{4}$ in. (.250 in.) and a minimum $\frac{3}{16}$ in. (.187 in.) have been laid down for the surfaces where the pedal mounting bracket seats of the rough side of the panel

Where a fracture has occurred on the face, this dangerous condition could be remedied by making up a mounting plate for the master cylinder attachment bolts; mounting this preferably on the inside of the panel and adjusting the thickness back to that specified above. This plate could be laminated or bolted in place.

(b) Headlamp Bowls and Surrounds

Where severe damage to the headlamp bowl and surround has occurred it is generally found more economical to fit a replacement bowl and section. It is essential for the correct operation of the headlamp assembly that the replacement section correctly positioned to this

end the new bowl should be attached to the pivot bobbins of the new section and tested for clearance in the up and down position before being bonded to the car.

The bowl should be fixed in the most convenient position by taping in place before laminating in the new section. Accessibility is restricted in this area and it may be found more advantageous to work through the actual lens unit hole.

Alternatively where a less serious impact has occurred and the lamps surround can be satisfactorily repaired without resorting to a replacement section it is recommended that a small jig be made to embrace both pivot mounting bolts of the bowl width. These can be screwed into the body bobbins serving to correctly locate them whilst providing sufficient access to bond them in and perform the desired repair.

(c) Side Frames

Where the body has suffered a broadside impact and the metal sideframe has been damaged it will be necessary to effect a repair. As the frames are constructed of mild steel it will be found possible to straighten these cold in less severe instances by using a wringing iron. The frames may be welded provided certain elementary precautions are undertaken to obviate fire risk. Damp rags and asbestos dough must be placed around the effected area.

Before any attempt is undertaken to weld or apply a flame to bend or straighten the frame it is advisable that a fire extinguisher be to hand and ready to use.

Where the frame is damaged at its attachment points to the body the bonding laminates must be chipped or ground away and after straightening be re-laminated as per chapter 4.

(d) Bumper Repairs

It should be noted that an indication of the structural failure of the foam filler due to a minor bump is the cracking of the surface finish in that area. If the bumper bar has suffered a more severe impact then it may be found that the foam filling has not returned to its original contour.

In both conditions it is firstly necessary to remove the point of damage from the outside, chamfering the edges of the outer skin and plug or fill the hole with a suitable polyester resin filler. The surface may then be reflashed in accordance with instructions for normal body finishing Feathering the repair towards the outer edges of the patch by using dry and wet paper in a rubbing down block.

(e) Repair Materials, Body Panels, etc.

Resin: Any good high grade commercial polyester resin can be used although it should have a reasonably high heat distortion point.

Filler: Any good polyester based filler material may be used for patching.

Glass Reinforcement: Normal "A" glass or "E" chopped strand mat may be used and where woven materials are used (e.g. over sideframes in some cars) this is more a matter of convenience than strength.

6—RECTIFICATION OF MINOR SUPERFICIAL DEFECTS

(a) Pin Holes or Air Voids

These are unfortunately quite inseparable from the hand layup system but since all body components are "overheated" to the maximum known service temperature of 180°F. (82°C.) in order to show up any voids before painting they should never in theory give any difficulty. If they do then the only solution is to dig them out and fill the holes with a polyester stopper or filler. Fig. 17 below shows two commonly used methods of filling these small holes. Generally speaking method "A" in which the holes are drilled or routed out so as to leave a larger hole with near vertical walls will be found more satisfactory than method "B" where the hole is enlarged by gouging or "picking out" as the latter procedure allows feathering and flaking of the edges of the filler.

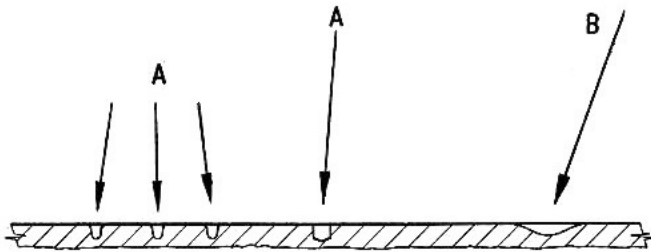

Fig. 17

A common problem of repaired pin holes is the sinking of the paint surface some time after the repair has been completed. This may result from the use of a cellulose paint stopper which has a higher rate of shrinkage or in the case of a polyester stopper is usually caused by painting too soon after effecting the repair or in other words before the filler is properly cured. Furthermore, the filled areas should on no account be rubbed down until the filler has fully cured, or sinking will obviously result.

(b) Surface Cracking

There are various causes of surface crazing, but practically all are caused by flexing the unsupported laminate beyond the point of resistance. Typical causes are sharp impacts or accidental damage. During an accident some panels may flex sufficiently to cause the surface to craze without causing immediate apparent damage to the paint surface.

This crazing may not work its way through the paint surface for some weeks so that it is necessary when assessing accident damage to carefully examine all panels, particularly near cracks or split bonds and in

cases of doubt it may be possible to promote the appearance of the crazing by applying gentle heat.

Crazing itself generally stops at the first layer of glass fibre and is consequently not in itself structurally serious, but the extensive crazing near damaged areas should be taken as an indication of over stressing and the panel should be reinforced or replaced or at least thoroughly examined. It is not possible to remedy crazing by simply re-surfacing with a further layer of resin.

(c) Wrinkling or Distortion

This phenomenon sometimes occurs on panels which were previously perfect and is usually caused by exposure to severe heat. This can cause the resin to soften slightly and in doing so give way to any inbuilt or associated stresses. In all such cases technical advice should be sought from the manufacturer.

(d) Split Bonds

Small splits of bonds such as those around the door can occur, being caused mainly by excessive flexing of the panels or by vibration and they should be arrested before they can extend and become serious. The split should be peeled open slightly further, the inside flange surfaces should be roughened up with a hacksaw blade and the appropriate type of bonding resin should be inserted before clamping up. Clamping pressure should always be applied evenly, using a small slip of wood or metal if dimpling of the panel surface is to be avoided.

(e) Replacement Sections

Where the repair of a damaged vehicle calls for replacement sections or panels it is recommended that these be obtained direct from the manufacturer.

Standard sectional repair moulds held by the manufacturer cater for the repair of damage in any area of the body unit. These are so designed that they can be used individually or connected together for the manufacture of the required section of the body. These are also incidentally, used for locating new sections correctly relative to the existing panels. These moulds are deliberately left unframed so as to accommodate slight discrepancies and have been made on a standard painted body shell to allow for average paint thickness.

To assist in conveying information on the damaged areas of the body shell it is recommended that use be made of the damage location chart (Fig. 18), further copies of which are available on request from Lotus Service Distributors. The exact location and extent of damage sustained (including internal panels) can be discerned by the manufacturers if **all** the relevant views on the diagram are marked up. For convenience the diagram is "squared up" at 6 in. increments and in measuring damaged areas it is suggested that these be taken from a centre line chalked or taped on the vehicle and/or from a vertical straight edge placed at right angles with the vehicle's normal ground level and against the side of the affected area.

LOTUS ELAN DAMAGE LOCATION CHART

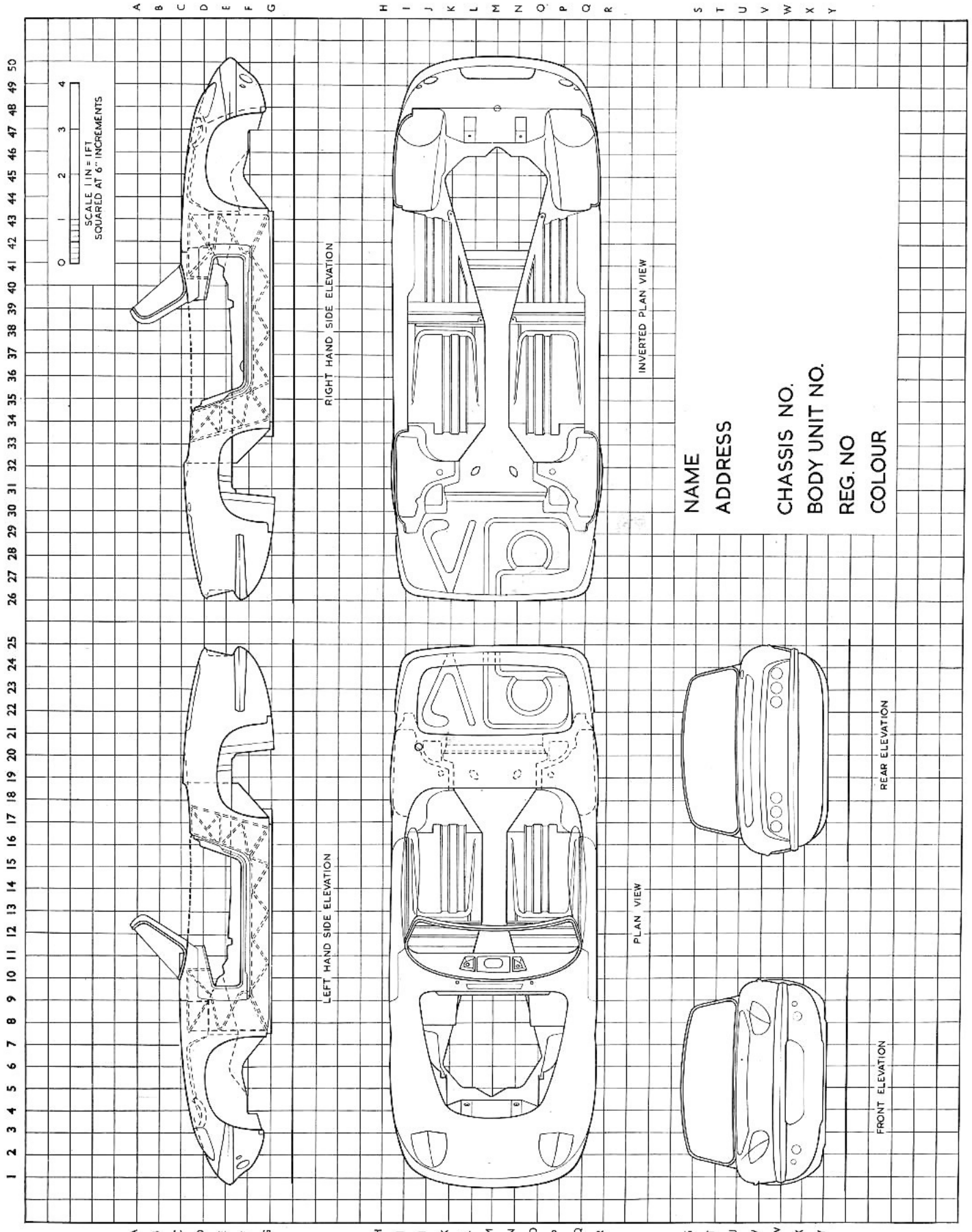

It should be mentioned that due to the material used in construction of the body unit, cases of severe damage can often be economically repaired. This gives an infinite advantage over contemporary vehicles of monocoque metal construction, i.e. where damage has been severe enough to destroy virtually the whole front end of the vehicle, as far as the bulkhead for instance, it is possible to graft on a new complete section.

In view of the fact that in no two cases will damage be exactly the same it is only possible here to lay down a few general rules, and for the remainder it is necessary to follow the basic principles of construction already described.

Before cutting away the damaged parts or ordering replacement sections, the proposed method of repair, positioning of joint lines, overlaps, etc. should be ascertained.

Remember the need to determine a method for the correct positioning of replacement sections and before cutting away damaged parts check on any prominent features from which measurements can be made and scribe these clearly on to the panels which are to be left intact.

Use masking tape or chalk to define the lines on which you propose to cut the panels away and study these lines thoroughly to see that (a) you will not be removing any undamaged or slightly damaged panel which would be useful in the aligning of another major panel. (b) On single skinned area in particular the proposed cut line traverses longitudinal, lateral and horizontal definition points to assist easy lining up of the new panel in all three places.

(f) Positioning Replacement Panels

- (i) Line up flat surface (e.g. undertray or floor area) using long wooden beams bolted to undamaged area.
- (ii) Line up main contours (e.g. wing sections) using splines and bolt into position with flat or curved steel straps.

(g) Metal Inserts

Apart from sideframes (see chapter 1) and mid-windscreen pillar "Z" section reinforcements the only metal inserts used are bobbins.

7—BOBBINS

Throughout the Elan considerable use is made of die-cast Mazak metal inserts, which are oval in configuration and commonly known as bobbins.

These are designed to carry high loads in most directions and also offer the advantages of being accurately located in the mountings.

Three basic forms are employed as follows :—

- Large (structural) bobbins—with $\frac{3}{8}$ in. or $\frac{7}{16}$ in. holes (plain or threaded)
- Small (semi-structural) bobbins—with $\frac{1}{4}$ in. or $\frac{5}{16}$ in. holes (plain or threaded)
- Door hinge cup bobbins—special.

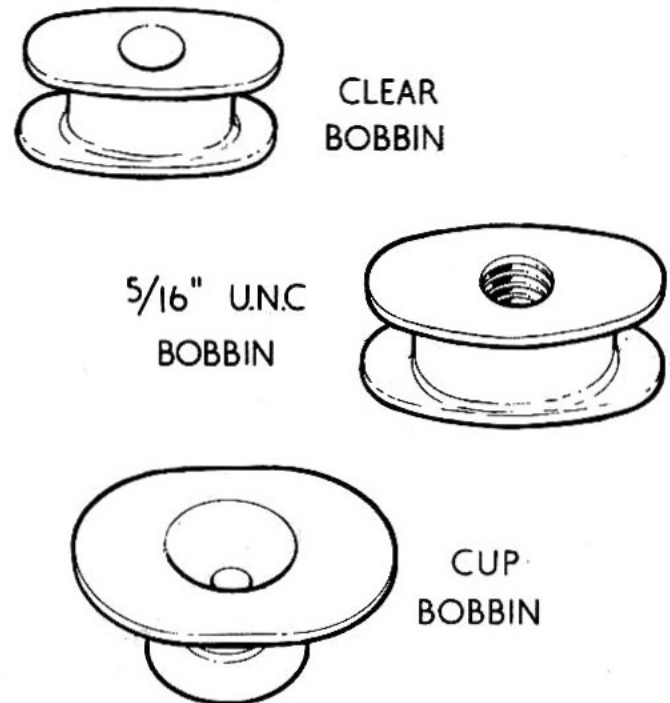

Fig. 19

Types of bobbin—Elan

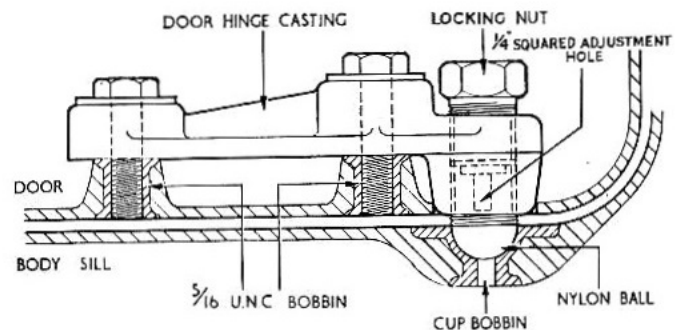

Fig. 20

Bobbins used in Door Hinge Structure

The following advice is offered on dealing with bobbin failures.

(a) Bobbins Pulling Out

This could be caused either by faulty layup (see Fig. 21) or by overloading, e.g. accident damage. Where the bobbin and its surrounding area is accessible from the

rough side of the laminates either naturally or by cutting non-weakening access holes (e.g. door hinge bobbin) the remedy is to improvise a local mould in plaster or glass fibre of the body surrounding the finished side of the bobbin.

In some circumstances a difficulty may be experienced in temporarily re-locating the bobbin and its surrounding laminate in its original position. A local mould of the smooth side of the surrounding area (for example 6 in. beyond in all directions) should eliminate this trouble. Re-registering is achieved by drilling holes through mould and body and through the bobbin before removing the repair mould.

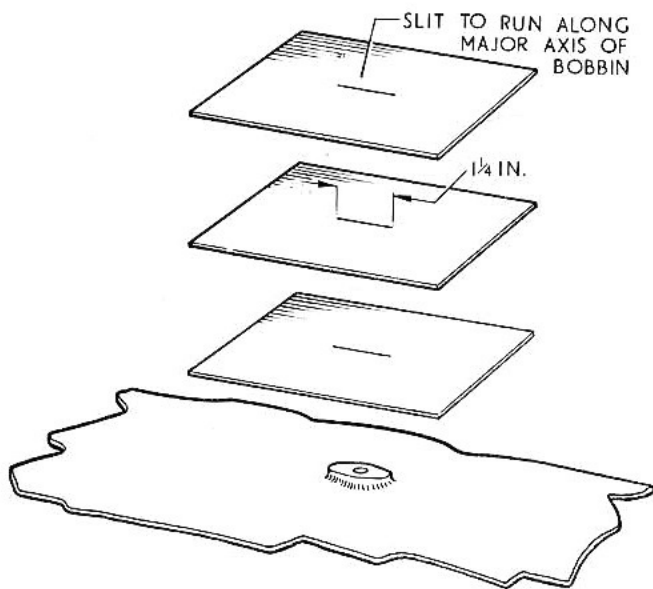
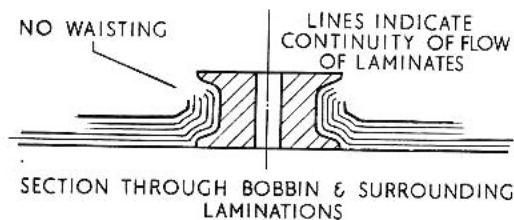

Fig. 21

Additional 4.00 in. square patches to make up to:—

(a) In the case of $\frac{1}{4}$ in. and $\frac{5}{16}$ in. bobbins: the equivalent of 5 x 1½ oz. layers.

(b) In the case of $\frac{3}{8}$ in. and $\frac{7}{16}$ in. bobbins: the equivalent of 7 x 1½ oz. layers.

NOTE:—Number of patches to be determined from the above note.

The bobbin can then be directly laminated on to the old mounting by using the techniques described in chapter 7 and overlapping the new laminate on to the old by several inches whenever possible.

Whereas the larger bobbins are used only where the loadings are known to be high, e.g. body mountings,

seat clamp plate attachments, etc. in many other cases it will be immediately apparent that the bobbins are being used as a locatory point or a blind attachment point than as a structural item.

Typical instances such as non-structural applications are headlamps, pivots, bumper retaining points, plenum chamber attachments, etc. In these latter cases loose bobbins can be repaired by more localised and less exacting means, e.g. forcing in a dough mixture around and behind the bobbin; winding tape around it, etc.

(b) Stripped Threads

Whilst their oval section will prevent these bobbins from turning in normal use they may start and loosen if too much tightening pressure is applied, or when an attempt is made to tap them out to a larger diameter. If a thread is damaged or stripped an attempt should therefore be made to drill the thread clear and use a bolt and lock nut or drill oversize and fit helicoil insert.

It should be mentioned that when fitting an initial check should be made with each bolt before tightening. Only U.N.C. bobbins are employed and particular care should be paid to fit only the U.N.C. bolts to them. These are outlined in Fig. 20 of this section. Where the bolts are particularly tight this may be due to resin within the threaded portion of the bobbin this may be remedied by tapping out.

Only the correct length of the bolt should be used, i.e. those whose thread engages with the full depth of the bobbin. No attempt should be made to pull items up under heavy load with a small engagement of thread. To avoid tightening up onto the plain shank of the bolt it is recommended that only set bolts be used, i.e. those threaded all the way up to the head.

(c) Laminating in a New Bobbin

Fig. 21 shows a typical oval ended bobbin and indicates graphically the requirements for a well laminated bobbin. Firstly the laminates from the basic mounting surface must overlap and interleave with the laminates around the bobbins. Secondly the laminate must be well built up under the bobbin to prevent the bobbin from pulling out in a downwards direction. This surrounding laminate should in itself comprise a tight ring around the bobbin to prevent it from bursting out under diagonal loads but if in doubt one or two layers of tape or cloth should be wound round the waist of the bobbin. Finally plasticine or similar plugs should be used during laminating to keep the resin out of the bobbin threads.

When properly laid as shown in Fig. 21 the visible rough side wall will be nearly vertical in line with the bobbin top profile. In effect a strong reinforcing ring of laminate surrounds the bobbin and this ring must be properly connected to the basic laminate.

(d) Notes on the Layup around Bobbins

(i) It is important that build up around bobbins is as shown in Fig. 21 bobbins by nature of their

application are subjected to high loads, and will break out of the surrounding fibre glass if not bonded in correctly.

(ii) Bobbins must be bolted to mould after "mould release agent" has been applied and prior to Gel-coat application. Care must be taken to ensure that it sits well down onto the mould, and that the bobbin is positioned correctly in accordance with the laminating drawing concerned.

It is essential to keep the Gel-coat to a minimum thickness to prevent "crazing" and desirable that the general layup thickness tapers gradually away from the bobbins.

Remember that tensile applications are the most demanding and require continuity of layup, that the above instructions be strictly adhered to, that the safety of the vehicle may be dependent upon the correctness of the application of these operations.

(e) Body Mounting Points—(special notes)

Reference Figures on Fig. 2.

When mounting body to chassis unit, a clearance between the rearmost mounting brackets and body behind the differential unit may be observed. Should this condition occur it is essential not to tighten the body down onto the brackets as consequential stressing of the body shell rearwards of the door apertures may open the door apertures and result in jamming and misfitting of the door. Spacing washers of 16g must be inserted, packing out until tightening can be effected without straining the unit. The 2 in. long U.N.C. bolts at the front also serve as mounting points for the two electric horns secured by Nyloc nuts, 7 and 8. An angle bracket serving as a mounting for the facia is secured by bolts 7 and 8 and 15 and 16.

SECTION Q
BODY EQUIPMENT

	<i>Chapter</i>
Hardtop components <i>Illustration</i>	
Hardtop components <i>Key to components</i>	
Fitting and use of hardtop	1
Bonnet catch adjustments	2
Door adjustments	3
Door locks	4
Door removal	5
Fitting a new side window	6
Windscreen replacement and removal	7
Installing a radio	8
Installation of the aerial	9
Fitting a tonneau cover	10
Fitting a new hood	11

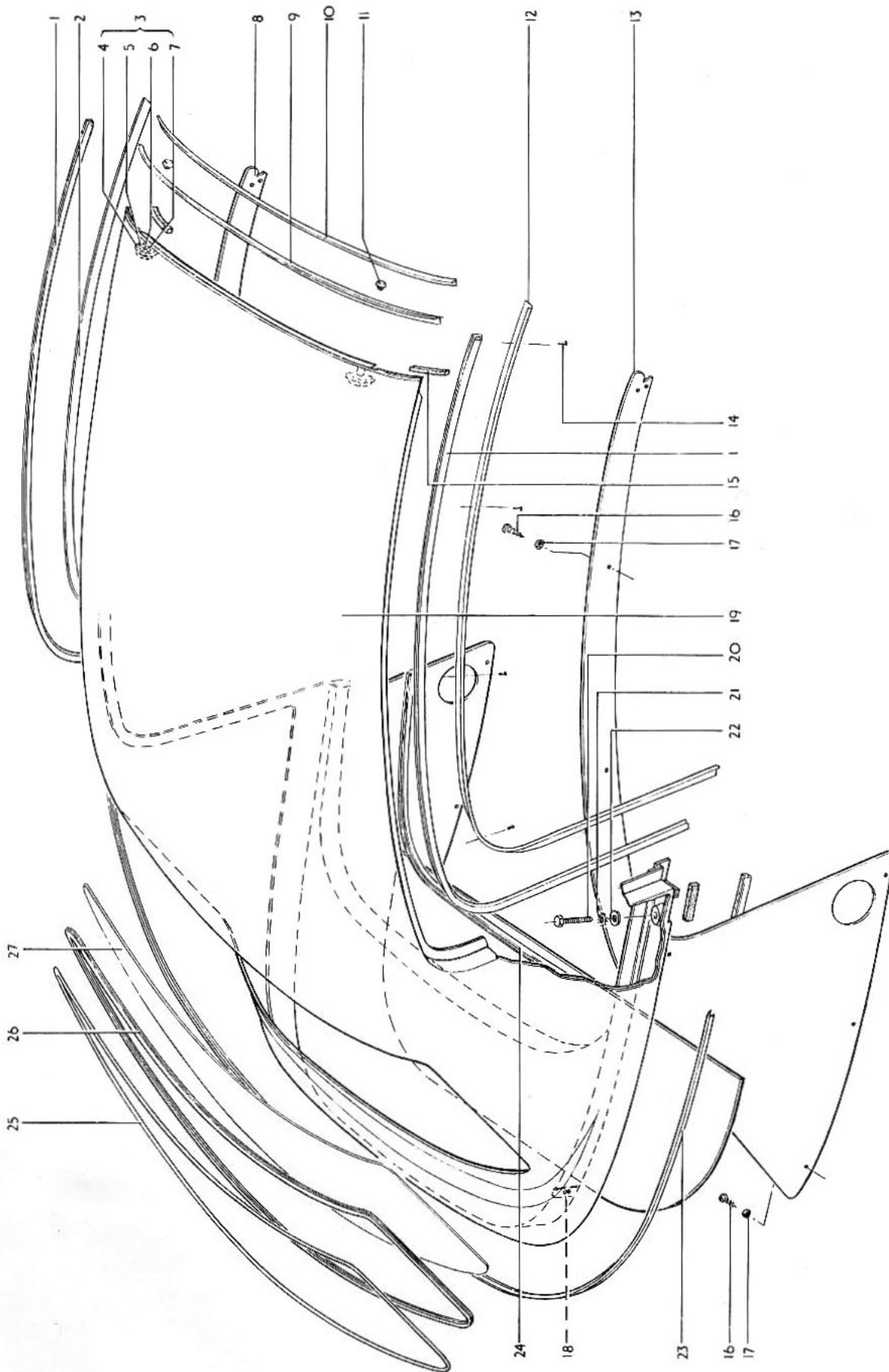

Fig. 1—HARD TOP ASSEMBLY

FILE NOT TO BE REDISTRIBUTED FOR PROFIT ORIGINAL COPYRIGHT HOLDER LOTUS CARS LIMITED 1966

KEY TO HARDTOP ASSEMBLY COMPONENTS

Key No.	Description	Key No.	Description
1	Seal (Hardtop to window glass)	15	Seal (Hardtop to windscreen frame)
2	Drip rail L.H.	16	Phillips No. 8 screw
3	Clamping assembly (Hardtop to windscreen frame)	17	Spire cup
4	Clamp plate (Hardtop to windscreen frame)	18	Spire speed nut
5	Clamp nut	19	Hardtop
6	Washer (clamping assembly to windscreen frame)	20	Screw
7	Circlip	21	Washer
8	Side trim panel L.H.	22	Washer
9	Seal (Hardtop to windscreen frame outer)	23	Seal (Hardtop to body)
10	Seal (Hardtop to windscreen frame inner)	24	Edging strip (parcel shelf edge)
11	Grommet (windscreen frame)	25	Filler strip
12	Drip rail R.H.	26	Weather strip
13	Side trim panel R.H.	27	Rear screen
14	Pop rivet		

1—FITTING AND USE OF HARDTOP

Before attempting to fit the hardtop in place on the Lotus Elan it is first necessary to remove the cant rail eye bolts and store them in a safe place and replace with the grommets supplied. The actual location of the hardtop is simple and straightforward although best done by two people for absolute convenience.

Inspection of the unit will reveal a flange approximately $\frac{3}{4}$ in. deep running across the front of the hardtop with rubber "flap" seals firmly affixed at both front flange and rear base conditions.

Remove the front screw clamp assemblies and then with one person standing each side of the car, carefully lower the hardtop into position so that the front flange rests immediately forward of the receiving gutter at the top of the windscreen surround frame. Having done this it will be found that lowering the rear end will bring the rear flange in close proximity with the boot hinges.

By carefully sliding the unit rearwards and downwards, taking care not to bend or damage the front corners of the trim panels as they locate against the windscreen frame corners, the front flange locates snugly into the front gutter and the rear flange similarly under the front of the boot hinges. In this position it should be checked that the sealing flaps have not been "turned down" at any point and that the hardtop is carefully located to receive the fixing bolts and clamps. Replace the screw clamp assemblies and tighten reasonably well.

Through the round holes in the side trim panels access can be gained to the oversize bonded in bobbins to take the fixing bolts. These are $1\frac{1}{2}$ in. x $\frac{1}{4}$ in. U.N.C. bolts which with the locking star washers provided, should be screwed down finger tight into the receiving bobbins in the top body at this point.

Before tightening down the bolts the front clamps should be fully tightened using a coin, only then should the rear bolts be screwed down using a ring spanner. Care should be taken not to over-tighten these bolts lest stripping of the thread form occurs with the corresponding expensive repercussions. Tightening the bolts should result in the hardtop being firmly located and deflection of the rubber weather seals.

The hardtop front seal should now fit tightly against the windscreen rubber thereby preventing wind noise. If wind noise is experienced it is probably due to one of the following reasons :

1. Hardtop has not been fastened down tightly enough and is "lifting" with suction at speed thereby opening the top front sealed joint.
2. A foreign body is in the windscreen frame groove or thereabouts and is preventing the hardtop from seating down properly along the front edge.
3. The front hardtop seal has been disturbed or loosened.
4. The windscreen frame, rubber or glass may have been improperly refitted if it has recently been disturbed

or replaced and may require expert refitting which should be carried out by an authorised Lotus Distributor or the Factory Service Department.

NOTE:—A hardtop should not be fitted to newly painted bodywork unless the paint is fully age hardened should this be unavoidable, then a protective film, e.g. waxed paper should be left in place for the first week or two.

Cleaning and Polishing Paintwork or Pigmented Surfaces

Painted and pigmented surfaces should first be washed down thoroughly to remove all trace of dirt, grease and grit, and allowed to dry. A siliconised wax polish is recommended but care must be taken not to apply polish to any of the glass areas. Apply the polish thinly with a soft damp cloth and allow to dry to a powdery appearance. Polish up with a dry cloth.

Headliner and Side Trims

Due to the nature of the synthetic material used headliner and side trims which become greasy may be cleaned easily with no fear of staining the fabric. The method advised is to sponge down the surfaces with a cloth damped in soap and water. **Polishes must not be used.**

Warning. Some early production hardtops are fitted with "perspex" rear screens and care should be taken not to scratch these when cleaning or polishing, nor to place articles on the rear shelf which may cause scratches. It is recommended that these perspex screens should be cleaned and polished with a proper preparation, e.g. Holts perspex cleaner.

2—BONNET CATCH ADJUSTMENTS

Close the bonnet lid noting where it is high or low in relation to the surrounding areas of the body.

(a) Front Adjustment

Adjustments for the front of the bonnet lid may be made by raising or lowering the nylon screws on the arc shaped slide rails.

(b) Rear Adjustment

Adjustments for the rear of the bonnet lid are effected by raising or lowering the vertical release catches. These catches are attached to the bulkhead by self tapping screws through elongated holes to spire nuts. The screws are accessible from the interior of the vehicle to the rear of the bulkhead and under the fascia.

Adjustment of the catch engagement can also be made by limiting or extending the amount of fore and aft travel of each catch. This adjustment is effected by releasing the locknut on the threaded end of the catch release outer cable in the engine compartment and a stop nut on the inside of the bulkhead. The threaded portion of the cable adjuster may then be moved in or out to obtain the desired catch location.

A further adjustment of similar nature is provided at the point where the end of the inner cable (threaded) passes through the release catch. This provides a finer adjustment than that previously mentioned.

3—DOOR ADJUSTMENTS

Open and close the door several times in order to ascertain the exact location of the rubbing or catching.

- (a) If the door has been dropped, the following procedure should be adopted. Remove the door bottom trim (this is secured by 2BA set screws). Removal of this trim will reveal the lower adjustment aperture. Slacken off the two top and the two bottom hinge bolts; proceed to lift the door slightly and retighten. Carefully close the door keeping a close observation of all door clearances at all stages. Should the door still not close correctly slacken off the bolts and repeat the procedure until it closes satisfactorily.
- (b) If the door is too high a similar operation to that described in (a) should be adopted.
- (c) In raising or lowering the door the catch may be altered in its orientation with the striker plate location on the body.
- (d) Some adjustments to the striker plate position may be necessary. Slacken the screws (Phillips headed $\frac{1}{4}$ in. U.N.F.) that secure the striker plate. Care must be exercised in not to slacken them too much as the threaded backplate may come away. With these screws slightly slackened the striker plate may be raised or lowered about the elongated holes. (a slight lateral movement may also be effected) whichever is required. Tighten striker plate screws, when the door is closing and locking satisfactorily. Finally check that hinge bolts and striker plate screws are tight and replace door trim.

4—DOOR LOCKS

(a) Removal

Remove the door trim. Undo the three U.N.F. bolts securing the door pillar chrome surround and door lock assembly to the door structure. Remove assembly from door. Remove the four Phillips screws securing the lock to the chrome pillar (three screws are located on the lock face and one screw on the adjacent face of the pillar) and withdraw the lock from the pillar. An examination of the lock assembly will reveal a brass pin on the barrel side. With a suitable pointed instrument depress the pin and at the same time withdraw the key. (The key must not however be in the vertical lock position nor turned during the withdrawing operation.) The centre of the barrel should then come out with the key.

(b) Replacement

Where a new lock is to be fitted remove the centre of the barrel in a similar fashion to that of the old assembly and replace the unit using a reversal of the procedure above. Oil lock before replacing trim.

5—DOOR REMOVAL

Remove the door trim. This will reveal the door hinge access apertures, unscrew the adjustable door hinge of top and bottom assemblies until the nylon balls are clear of each cup bobbin and remove door (see Fig. 2).

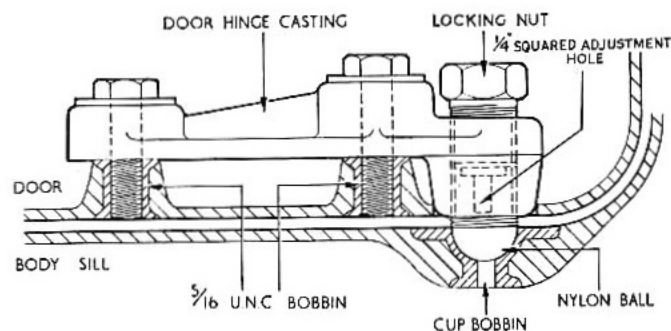

Fig. 2

The Door Hinge Assembly.

6—FITTING A NEW SIDE WINDOW

Remove door side trim. Remove self tapping screws securing inner trim panel and chrome edging strip. Take off chrome strip and withdraw inner trim panel by sliding upwards in the fore and aft runners.

On lifting the window to its highest point it will be observed that it is retained by two $\frac{1}{4}$ in. U.N.F. bolts.

Unscrew the bolts and lift the window and mechanism upwards on its runners until it is clear of the doors.

The new window is positioned in a similar manner (make sure the runners are well greased). Getting the window to run smoothly in its runners is achieved by trial and error, i.e. by packing out the runner securing bolts and the sliding mechanism bolts with spacers and trying the window motion again. A certain amount of fore and aft movement is made available by the elongated holes in the runners.

When the window motion is satisfactory, replace the chrome surround and door trim. Remove the door lift from the old window and replace on new assembly carefully.

7—WINDSCREEN

Removal and Replacement

The joint of the brightwork strip surrounding the windscreen will be found in the centre of the upper half of the rubber shock pad in which the screen is encased. The strip is of Tee shaped section fitting into a groove in the rubber shock pad. Insert a suitable tool into the joint and lever outwards until the end can be grasped. Pull the strip out of the rubber pad and press the screen and pad outwards over the bonnet of the car. It is advisable to put a protective cover over the paintwork on the scuttle to prevent damage.

Slacken the tension wire in the centre of the windscreen at its lower end. This is effected by unscrewing the nipple, the squared end of which projects just above the facia padding on the top of the scuttle. A bicycle spoke key can be used with a suitable extension.

To replace the windscreen locate the rubber shock pad round the screen and press it into position on the car. Ensure that the rubber lips are correctly positioned both on the screen and on the flange provided for location on the body of the car, and that the slot in the pad faces the outside of the car as shown in the section.

Place the brightwork strip into the Special Tool (see Fig. 3) so that the face side goes under the roller from the handle slide, up through the loop of the tool with the end of the strip directly below the roller.

Insert the loop of the tool into the slot in the shock pad at the lower centre of the windscreen and push the tool and strip along the slot, the slot will be separated by the loop of the tool to allow the rib of the brightwork strip to enter the slot and the roller will press the strip into place.

Continue round the full periphery of the windscreen until the tool butts up against the end of the located strip. Skilful manipulation is required around the four cornered radii of the screen and to prevent the flexible strips from buckling it may be necessary to "run" the section backwards and forwards a few times or even to soften it slightly by heating gently.

Remove the tool from the slot and press the remaining inch or so of the strip into place. Re-adjust the tension on the central wire in a similar fashion to that of a bicycle spoke.

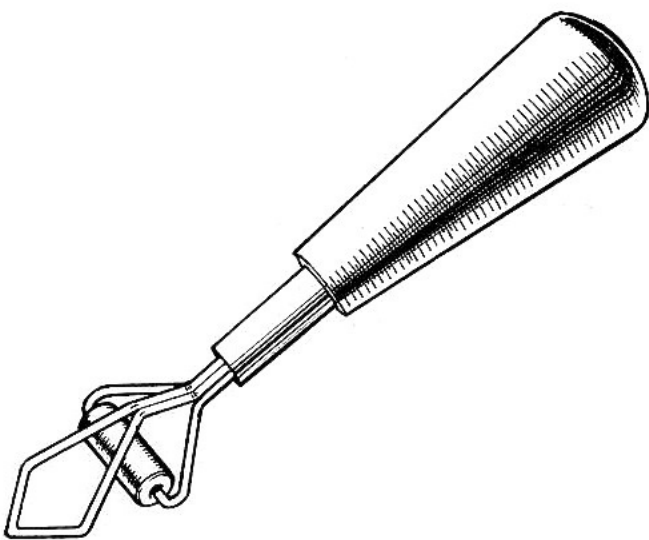

Fig. 3
Brightwork strip insertion tool

8—INSTALLING A RADIO

Disconnect the battery.

It is necessary to withdraw the facia panel and instruments. This is accomplished in the following manner. Disconnect the choke control and heater control cables, oil pressure pipe bonnet release cables, speedometer cable (at head) headlight vacuum pipes (at facia end), steering column clamps, the two glove pocket attachment bolts (one $\frac{1}{4}$ in. x $1\frac{1}{4}$ in. U.N.C. located upwards through-out the middle of pocket and one 2BA just below cigar lighter position).

Lower steering column and remove glove pocket. Removal of royalite tunnel trim and gear lever will reveal the bottom mounting bracket for the facia. Undo the facia securing bolts (four $\frac{7}{8}$ in. Phillips headed screws) located at top of the facia and four $\frac{5}{16}$ in. coach bolts located on the bottom of the mounting bracket.

Withdraw the facia to a distance limited by the free length of the wiring loom. Remove the cigar lighter from the facia and carefully cut out the rectangular aperture, scribed on the back of the facia board.

Removal of the speaker grill from the top centre of the crash pad may reveal an oval aperture in the fibre glass panel. Should this not be the case (earlier models) it is necessary to offer up one of the speaker gaskets supplied and use as a template to mark the aperture prior to cutting out.

Drill the four mounting holes for the speaker by using gasket as template initially. Connect the wires to the speaker (taking care not to connect both wires to the same pair of terminals) secure speaker in position with the nuts and bolts supplied and ensuring that one gasket is inserted between the fibre glass body and the unit the remaining two—between the speaker and grill. Re-fit the grill.

Remove the knobs from the radio (pull off) taking care not to lose securing clips and washers, etc. Unscrew the two black plastic nuts from the control spindles and remove the facia plate and chrome surround of the unit. Fit the mounting brackets to the radio chassis (secured by 2BA screws). Push the radio through the aperture in the facia (chassis first) then refit the chrome surround and facia plate retained by the two black nuts, making sure that those are only finger tight.

Replace control knobs. Run the lead from the radio to the spare terminal on the ignition switch and plug in the in-line fuse connection. Connect the wire already secured to the speaker to the socket connection on radio.

NOTE:—It is essential to test the radio at this stage before replacing the facia.

Plug in the aerial connection and run the lead to a suitable earth. Temporarily connect the battery and turn on the ignition switch and the radio switch.

If radio does not function properly check all wiring connections including those of battery and fuse and earthing of aerial lead, etc., until the fault is found.

Replace fascia by reversal of the procedure outlined for its removal making sure that the aerial attachment is accessible after re-assembly.

Replace glove pocket and reposition steering column.

9—INSTALLATION OF THE AERIAL

Fitting

Mark out a position for aerial hole in front nearside corner of boot, making sure that aerial will retract unimpeded into boot. Carefully drill a hole. Fit aerial, tracing out a suitable path for the earth strap to one of the small differential bush securing bolts. (As boot is a non-conducting fibre glass). Drill a hole in the offside front corner of boot (forward or offside differential mounting bush). Thread wire from aerial through the hole under the trim at the back of seating compartment. Remove the offside trim panel (secured by self-tapping screws and cup washers).

Attach aerial extension lead to wire at back of seating compartment and run wire behind boot, reinforcing struts (revealed on removing side trim) and proceed to run wire under the foot box floor trim and up behind base of dash to plug already attached to radio.

Screening or Suppressing

Attach suppressors to dynamo coil.

NOTE:—Attach suppressor to large terminal of dynamo. Fit aluminium screening plate between rear of engine and body bulkhead securing it by the two top bell housing bolts, making sure to cut out a space for engine breather pipe. Fit aluminium cover over sparking plugs (held in place by spring clips). Fit aluminium cover over coil by bolting it to offside body stay. Fit earth strap from airbox flexible ducting clip to body stay chassis bolt. Lastly fit earth strap from coil to chassis.

10—FITTING A NEW TONNEAU COVER

1. Place tonneau cover evenly over cockpit of car, making sure that this is equal at both sides. Hook tonneau into chrome clips situated at rear of cockpit.

2. Press edges of tonneau cover evenly onto each stud to mark positions for fitting press studs (this should be approximately in centre of reinforced edge of tonneau). When mark is made cut a $\frac{5}{16}$ in. diameter hole centrally round mark and place the top section of press stud through hole, finish by screwing base plate on tight. Repeat this operation until all press studs with the exception of the one on each door front edge are fitted making sure after each one that the position of the tonneau cover has not changed.

3. The front studs fitted on the front edge of the door (one each door) requires a $\frac{7}{16}$ in. diameter hole cutting as the tonneau cover is double thickness at this point. The press studs are then fitted in the usual way.

It is to be noted that the four press studs at the front of the tonneau cover are smaller than the remaining ten which are fitted on both sides and rear of the cockpit.

11—FITTING A NEW HOOD

1. Fit hood sticks on to points provided on cant rails.
2. Clip rear of hood under two chrome attachments on rear of body section.
3. Fit front of hood into channel on front of windscreen frame top.
4. Pivot rear hood sticks into position and fasten press studs provided.
5. Fit rear of hood into studs at rear of cockpit.
6. Stretch hood over cant rails to ensure that it is situated centrally on car.
7. Smear white chalk onto press studs fitted to cant rails to enable position of press studs to be identified.

Starting from the front of the hood press the hood on to each stud in turn and when a mark is made with chalk cut a $\frac{3}{16}$ in. hole in the centre of mark on hood.

Fit domed section of press stud into hole and place lower section over the stem of this then using a suitable drift pin over end of stem so securing it.

Repeat this operation until fitment of all studs is completed.

FILE NOT TO BE REDISTRIBUTED FOR PROFIT ORIGINAL COPYRIGHT HOLDER LOTUS CARS LIMITED 1966

SECTION R

OVERHAUL AND REBUILD INSTRUCTIONS

	<i>Chapter</i>
General	1
Preparation	2
Paintwork	3
Threads	4
Sides	5
Assembly	6

Where it is self evident, instructions for dismantling are not given in this section.

Reassembly Instructions—BODY UNIT WRITE OFF.
Refer to the applicable paragraph relative to the accident damage.

1—GENERAL

If damage to the body unit has been so extensive that it cannot be reasonably covered by repair schemes outlined in previous chapters, advice should be sought from Lotus Cars (Service) Ltd. Full details of damage, direction of impact and extent of fractures must be given. It is often found in more serious cases of accidental damage, that a complete replacement body unit proves a more economical proposition. Assembly details and procedures are outlined on the ensuing pages, and it is assumed that all other units are undamaged or have been replaced.

2—PREPARATION

It is necessary to support the body on two strong wooden trestles. At no time should the body be lifted by the wheel arches, radiator air intake or bumpers. It is as well to remember at this juncture, that if the car is positioned under a substantial beam or girder, engine installation will be greatly facilitated.

Doors, boot and bonnet: Until the car is complete it is advisable to use care with these parts. Do not slam them unnecessarily or force the doors on their hinges. The bonnet should be removed for easier access to the engine compartment by unhooking the spring at the forward end, from the bonnet.

3—PAINTWORK

This should be protected at all stages of assembly by means of a dust sheet or similar covering. Do not use plastic covering as this could damage the paint.

4—THREADS

Should it become necessary to replace a lost or damaged nut or bolt, check thread size carefully.

5—SIDES

In the following instructions, references are made to left-hand side and right-hand side of the car; these are as seen from the driving position.

6—ASSEMBLY

The front suspension is handed and it is essential that the two assemblies are not mixed. On cars with "bolt on" wheels it should be noted that from the hub out-

wards the parts are not handed, and are, therefore, not coloured. Description of the assembly of the right-hand side front suspension is as follows:

- (a) Select the hub assembly for the right-hand side marked with GREEN paint and offer to top wishbone which should be mounted on chassis, bolt lightly.
- (b) Hang damper spring unit from chassis post and offer up wishbone assembly. Connect trunnion to bottom wishbone using the outer holes on the wishbone. Connect damper unit to wishbone using the rear holes of wishbones.
- (c) Unscrew track rod end, screw up exactly twenty-five turns, then connect track rod end to steering assembly. Torque load the nuts to 26/28 lbs. ft.
- (d) Connect brake hose to caliper ensuring copper washers are seated correctly on each side.
- (e) Assemble the left-hand side in a similar manner. Left hand hub is marked with RED paint.
- (f) See paragraph "h.e" on final tightening of suspension.

Note—Red and Green are the international colours for port and starboard, i.e. LH and RH.

(b) Roll Bar

The roll bar cannot be assembled to the car the wrong way providing force is not used because of the angles of the chassis mountings to which the links are fitted.

Offer roll bar links into mounting points on chassis and bolt up, using no washers. Swing roll bar forward until pegs on damper are in line with holes in roll bar. The sequence of fitting bushes is as follows: steel washer, bush, steel washer, roll bar, steel washer, bush, steel washer, nut, lock nut. The front suspension is not tightened and should be left with all four main wishbone nuts slack.

(c) Engine/Gearbox

Remove the gearshift lever and the tunnel top.

Lay propeller shaft in its tunnel and remove gearbox rear support from the chassis. Do not at this stage connect the propeller shaft to the differential unit.

For engine fitting, it is essential that correct slinging is achieved. Two slings are used, one passing below the crankshaft pulley and behind both the dynamo and water pump. The other sling is at the forward end of the bell housing, taking care not to catch or damage the clutch fork. When the engine is lifted it should be inclined downward approximately 30° with the engine unit in its correct position prior to fitting, connect the fuel feed pipe to the fuel pump, breather oil pipe, gearbox mounting plate, then attach and secure both right- and left-hand engine mountings.

With the slings in position, raise the rear end of the gearbox and fit the rear mounting to the chassis. Connect rear end of propeller shaft to the differential unit.

Fill gearbox with 1½ pints of the recommended oil, then refit the gearbox lever together with its sealing grommets. Ensure that large nylon gear lever cap is fully and correctly tightened down by use of a chisel-shaped punch

and hammer. Remove engine slings and refit tunnel top. Fit gear lever locknut and knob.

(d) Differential Unit

Refitting

1. Fill the differential unit to its correct level with one of the special oils as given under the heading "Recommended Lubricants" in the Owner's Handbook.

2. Lift the differential unit into position from the left-hand side and adjust unit to give a clearance between the top of the unit and the chassis cross-member of $5/32$ in. maximum and $3/32$ in. minimum—ideally $\frac{1}{8}$ in. This may necessitate the removal of *one* of the *two* washers on either or both sides. A minimum of *one* washer must be left between the top lugs of the differential unit and the chassis cross-member and between the head of the bolt and the rubber mountings. It is essential that the large 2 in. diameter washers are used and not substituted by others, as they serve a two-fold purpose in being both spacers and stopping the rubber bushes from spreading.

3. Attach the forward ends of the differential unit torque rods, following with the propeller shaft retaining nuts and bolts. Reconnect the left-hand lower wishbone, ensuring that the spacer washers are located between the wishbone and the bearing housing. Note that the long bolt is fitted towards the front of the car. The torque rod rubbers (at the differential end) are assembled in the following sequence from the front:

Rubber bush (next to fixed washer), cup washer with large hole, differential unit lug, cup washer with large hole, rubber bush, cup washer with small hole, then finally the nut which should be torque loaded to 22/27 lbs ft.

4. Attach the outer end of the drive shaft to the Rotoflex coupling, ensuring that the brake disc is running true within the caliper. Torque load the nuts to 35/40 lbs ft.

5. Jack up the left-hand bearing housing from below the damper, to enable the inner end of the drive shaft to be attached to the other Rotoflex coupling. It will be found easier to insert a bolt through the upper hole in the coupling and the lower hole in the driving flange, finger tightening this bolt. The other bolts can now be fitted by rotating the shaft around the one fixing bolt inserting the bolts from the driving shaft side. Finally torque load all nuts to 35/40 lbs ft. and remove the coupling clamps.

6. Fit handbrake rod to caliper, ensuring that the spacer is fitted in the clevis before attaching. Lubricate clevis and pin with Shell Retinax "A" grease. Do not fully tighten nyloc nut as this is a pivot.

7. Refix trim in luggage compartment where this has been disturbed.

8. Refit road wheels and lower car from chassis stands. Check security of wheel retaining nuts when the car is standing on its wheels.

9. See paragraph "h.e." on final tightening of suspension.

(e) Rear Suspension

Attach rear wishbone radius arms to their locations on the chassis, noting that the straight part is towards the rear of the car. Do not fully tighten bolts. Fit wishbone to rear bearing housing, again do not fully tighten the bolts. Remove split pin and castellated nut from the damper spindle. Insert a piece of wire through the split pin hole in the top of the damper spindle to guide the spindle through the hole in the body then balance the assembly on a hydraulic jack and jack-up the assembly such that the spring is compressed enough to enable an assistant to pull on the wire to guide the spindle through the body and then to fit the castellated nut and split pin (after removing the wire) to the damper spindle when the assembly is in its correct location in the car. The hole in the top spring abutment is "D" shaped, ensure this lines up with the damper spindle.

Take care when using the jack as a reasonable amount of pressure is required to compress the spring. Ideally, the spring should be compressed before attempting to fit the assembly into the car. Great care should be exercised when compressing the spring that fingers and limbs are well clear of the spring coils and the end of the damper spindle, otherwise a serious injury could be caused to the operator should the spring slip when it is being compressed. After compressing, clamp the spring in the closed position with the aid of stout leather straps, or spring compressing clamps. Tighten the wishbone bolts after the suspension assembly has been secured before removing jack. The drive shaft can now be fitted to its coupling as given under "Refitting the Differential Unit". When the suspension has been fitted to one side of the car, the same procedure must then be adopted for the other side of the car. See paragraph "h.e." on final tightening of suspension.

Note—On cars with "knock on" wheels, the left-hand hub and bearing housing is coloured RED and the right-hand hub and bearing housing is coloured GREEN. On cars with "bolt on" wheels, the parts from the hub outwards are not handed and are therefore not coloured.

(f) Handbrake Linkages

After fitting the handbrake rods to the calipers, all pivot points should be adequately lubricated with Shell Retinax "A" grease. Adjustment is effected by first ensuring that the rods and cables are in fully retracted position, i.e. that the rear brake discs are free to rotate then, with the wheels in a horizontal position carry out adjustment at the brake calipers by means of the knurled nuts to give a clearance of .003 in. maximum each side of the disc. Any excess slack in the cable can now be taken up with the adjuster which is located in the right-hand engine insulator support chassis lug.

(g) Auxiliaries in Engine Bay

Exhaust system with cast manifold

Fit exhaust system which is in three parts, noting that no gasket is used between the manifold and the downpipe.

Use Holts "Firegum" as a sandwich between the two flanges on Special Equipment models. This material sets rather quickly, so no time should be lost in assembling the manifold to the downpipe.

From below the car fit intermediate pipe to downpipe, then fit silencer assembly to intermediate pipe and into housing in body and connect straps.

Exhaust system with fabricated manifold

Drill a $\frac{7}{16}$ in. (11mm) hole through the top flange of the L/H chassis leg, $7\frac{1}{2}$ in. (18cm) rearwards of the engine support foot, and $1\frac{1}{4}$ in. (32mm) from the inner edge of the flange. Paint the edges of the hole to avoid the formation of rust.

Fit the clutch fluid pipe to the master cylinder, pass the pipe through the hole in the chassis, fit nylon hose sandwiching the chassis between fibre washers, attaching the free end of the hose to the *inner* tapped hole on the slave cylinder. The bleed screw is refitted in the *outer* tapped hole.

1. Jack-up previously fitted engine and support with a suitable stand. Remove the generator and the L/H engine mounting.
2. Fit gaskets to exhaust flanges on the cylinder head, then working from below the car, fit the appropriate manifold to flanges 1 and 4 and the other manifold to flanges 2 and 3. No force is required for this operation, it will be found that the manifolds fit quite easily to their respective flanges. Secure manifolds to the cylinder head with the 8 brass nuts.
3. Still working from below the car, fit 'Y' box with its clips to the lower ends of the manifolds and to the intermediate pipe and into housing in the body, then connect straps.

Check for clearance throughout entire length of exhaust system, finally tightening all bolts. Working on the left-hand side of the engine, the following connections should be made:

- (a) Water temperature sender unit and capillary, noting that this is in the forward hole of the thermostat housing. The capillary should be clipped to the heater water valve, then three or four coils of approx. 2 in. diameter added to take up flexible movement of the engine and thus avoid breakage of the capillary at its junction with the sender unit. A further clip should be added to the capillary utilising one of the screws which retains the chassis plate to the body.
- (b) Combined heater water elbow and heater water valve, noting that this is the rearmost hole in the thermostat housing. Fit hose after cutting to length, ensuring it does not chafe on any sharp projections. Connect water valve operating cable so that when knob on fascia is pushed in, the water valve is closed. Check operation of knob after attaching cable.
- (c) Connect cables to dynamo; yellow and green cable to small terminal, brown and yellow cable to large terminal.

On the right hand side of the engine, the following connections are made in the order written:

- (a) Starter cable to solenoid (black).
- (b) Contact breaker cable (black/white) to distributor.
- (c) Connect heater hose to pump after cutting to length. Connect oil pressure feed pipe to union which is just in front of the distributor, ensuring that the pipe is not fouling the heater pipe. Connect speedometer drive.
- (d) Fit clutch pipe to master cylinder at its upper end and to the slave cylinder at the lower end. Secure with clip to gear box mounting bracket.
- (e) Remove air box outer cover by releasing the one central holding bolt. Do not disturb the backplate of the air box as the securing nuts which also retain the carburettor trumpets have been assembled with "Loctite" to ensure the security of the nuts. The carburettors are retained on the inlet manifold stubs by washers and nyloc nuts which are assembled in the following sequence from the carburettor flanges outwards: plain washer, double spring washer, plain washer, nyloc nut. Tighten all nuts to give a .040 in. clearance in the coils of the spring washers, this in turn giving a designed total up and down movement at the trumpets of $\frac{1}{8}$ in. This flexible mounting of the carburettors is necessary to minimise frothing of petrol in the float chambers. Connect throttle cable by pushing nipple through the hanging bracket, and sliding the outer cable ferrule into the nipple on the throttle linkage. The return spring is fitted at the lower end by pushing into hole in the hanging bracket. Connect the choke control cable by first releasing the short centre outer cable piece from between the two carburettors, then, thread the inner cable through the holding bracket on the rear carburettor and nipple, push the inner cable through the previously removed short piece of outer cable, then push the inner cable into its nipple on the front carburettor. Ensure that the choke control on the fascia panel is in the fully forward position, i.e. closed, then secure the outer cable at the rear carburettor following with securing the inner cable at the rear carburettor and repeat the procedure for the front carburettor. Check the action of the choke control at the fascia by pulling and pushing the knob, ensuring that the choke is opening and closing as required. Replace air box outer cover with its two securing bolts ensuring that the seal is in contact throughout its periphery, then tighten bolt. Attach air trunking to the air box with its jubilee clip. Fit radiator by inserting the mounting bolts through the top hole in the top bracket and through the centre hole in the lower bracket. Ensure radiator is vertical. Connect bottom water hose to water pump and top hose between thermostat housing and radiator header tank. It is essential to note that when hoses are fitted they are not flat or twisted or fouled by other components, i.e. steering column, etc.

(h) Final Assembly

- (a) Check all oil levels using recommended lubricants and capacities as shown in the Owner's Handbook. Bleed clutch, connect battery cables in boot and check radiator for correct coolant level and leaks. It is

important to note the polarity of the battery before connecting the cables (see Owner's Handbook). Incorrect connection of battery cables could result in damage to electrical equipment, particularly those fitted with transistors, i.e. Radio.

- (b) Bleed brakes. Ensure that brake fluid does not come into contact with body paintwork.
- (c) Fit road wheels and adjust tyre pressures, including spare (see Owner's Handbook). Lower car from Chassis stands to floor.
- (d) Replace the bonnet and attach its spring.
- (e) **IMPORTANT**

With the vehicle standing on its wheels, insert wooden blocks beneath each front lower wishbone fulcrum shafts and beneath each rear chassis leg adjacent to the wishbone pivot but NOT touching the pivot. Load the vehicle with weights on the front and rear centre line until the blocks are just nipped, not bearing heavily down on them, then tighten all wishbones and suspension mountings. Check steering geometry as given in the Owner's Handbook. The height dimensions of the blocks should be:

Front	6 $\frac{1}{8}$ in.
Rear	6 in.

- (f) Engine is now ready for starting. Before switching "on" ignition press starter solenoid and turn engine over until oil pressure is indicated on the gauge. Switch "on" ignition and start engine (see "Starting Procedure" in Owner's Handbook). Adjust slow running speed to between 900 and 1,000 r.p.m. The slow running speed is adjusted by the throttle screw located on the rear carburettor. Only one screw is provided. The other screws are the mixture (volume) control adjustments, and the butterfly (throttle flap) adjustment. Refer to section 'M' before attempting to adjust the last mentioned screws.
- (g) Road test and "run in" the car to the recommendations given in the Owner's Handbook.

If the car has been rebuilt by a private owner or non-Lotus Dealer it is recommended that the advice of an approved Lotus Dealer is sought in checking the workmanship of rebuild, especially as far as safety is concerned.